

TM 11-5805-387-34-2

**TECHNICAL MANUAL
DIRECT SUPPORT AND GENERAL SUPPORT
MAINTENANCE**

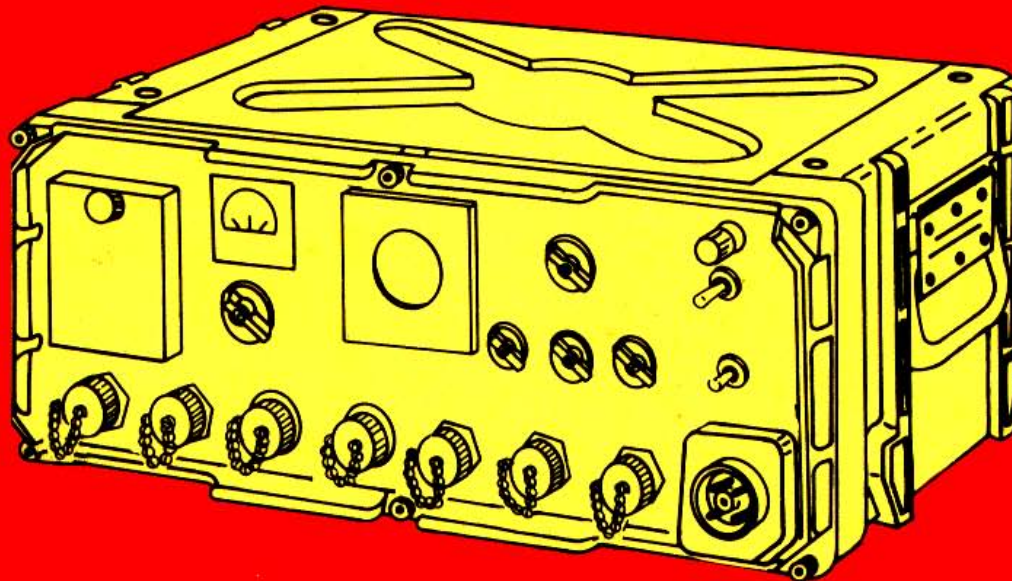

**EQUIPMENT DESCRIPTION
AND DATA**

Page 1-4

**TECHNICAL
PRINCIPALS OF
OPERATION**

Page 1-5

**DIRECT SUPPORT
MAINTENANCE**

Page 2-1

TROUBLESHOOTING

Page 2-4

**MAINTENANCE
PROCEDURES**

Page 2-27

**ADJUSTMENT
PROCEDURES**

Page 2-33

**GENERAL SUPPORT
MAINTENANCE**

Page 3-1

TROUBLESHOOTING

Page 3-1

**MAINTENANCE
PROCEDURES**

Page 3-22

MODEM RADIO TELETYPEWRITER

**MD-522A/GRC
(NSN 5815-00-919-4800)**

HEADQUARTERS, DEPARTMENT OF THE ARMY

11 MAY 1984



5

**SAFETY STEPS TO FOLLOW IF SOMEONE
IS THE VICTIM OF ELECTRICAL SHOCK**

1

DO NOT TRY TO PULL OR GRAB THE INDIVIDUAL

2

IF POSSIBLE , TURN OFF THE ELECTRICAL POWER

3

**IF YOU CANNOT TURN OFF THE ELECTRICAL
POWER, PULL, PUSH, OR LIFT THE PERSON TO
SAFETY USING A WOODEN POLE OR A ROPE OR
SOME OTHER INSULATING MATERIAL**

4

SEND FOR HELP AS SOON AS POSSIBLE

5

**AFTER THE INJURED PERSON IS FREE OF
CONTACT WITH THE SOURCE OF ELECTRICAL
SHOCK, MOVE THE PERSON A SHORT DISTANCE
AWAY AND IMMEDIATELY START ARTIFICIAL
RESUSCITATION**



DON'T TAKE CHANCES!

CAPABLE OF CAUSING DEATH

HIGH VOLTAGES EXIST IN THE FOLLOWING EQUIPMENT:

Various connectors and power supply components.....	27 VDC
DC LOOP NO. 1 and DC LOOP NO. 2 connectors.....	120 VDC
Loop battery module A5.....	127 VDC
Scope module A2.....	1,100 VDC

**USE EXTREME CAUTION WHEN
HANDLING, TESTING AND ADJUSTING**

DO NOT SERVICE OR ADJUST ALONE

Do not attempt internal service or adjustment unless another person, capable of rendering first aid and resuscitation, is present.

SAFETY PRECAUTION

A periodic review of safety precautions in TB 385-4, Safety Precautions for Maintenance of Electrical/Electronic Equipment, is recommended. When the equipment is operated with covers removed, **DO NOT TOUCH** exposed connections or components. **MAKE CERTAIN** you are **NOT** grounded when making connections or adjusting components inside the test instrument.

USE CAUTION WHEN EXPOSING OR HANDLING THE CRT

Breakage of the cathode-ray tube (CRT) causes a high velocity scattering of glass fragments (implosion). To prevent CRT implosion, avoid rough handling or jarring of the instruments. Handling of the CRT shall be done only by qualified maintenance personnel using approved safety masks and gloves.

WARNING
RADIATION HAZARD



RADIOACTIVE MATERIAL
CONTROLLED DISPOSAL REQUIRED
ACCOUNTABILITY NOT REQUIRED

Meter	Ra 226.....	1.0uCi.....	6625-00-257-1103
Meter	Ra 226.....	0.6uCi.....	6625-00-226-5680
Meter arbitrary scale	Ra 226.....	1.0uCi.....	6625-00-226-5679
Meter, arbitrary scale	Ra 226.....	1.0uCi.....	6625-00-226-5681

Radiation Hazard Information: The following radiation hazard information must be read and understood by all personnel operating or repairing Radio Teletypewriter Sets AN/GRC-142, AN/GRC-142A, AN/GRC-142B, AN/GRC-122, AN/GRC-122A, and AN/GRC-122B. Hazardous radioactive materials are present in the above listed components of the MD-522AIGRC, RT-662/GRC, RT-824/GRC, and the AM-3349/GRC. The components are potentially hazardous when broken. See qualified medical personnel and the local Radiological Protection Officer (RPO) immediately if you are exposed to or cut by broken components. First aid instructions are contained in TB 43-0116, TB 43-0122 and AR 385-11.

NEVER place radioactive components in your pocket. Use extreme care NOT to break radioactive components while handling them.

NEVER remove radioactive components from cartons until you are ready to use them.

If any of these components are broken, notify the local RPO immediately.

The RPO will survey the immediate area for radiological contamination and will supervise the removal of broken components.

The above listed radioactive components will NOT be repaired or disassembled.

Disposal of broken, unserviceable, or unwanted radioactive components will be accomplished in accordance with the instructions in AR 385-11.

C/(D blank)

**DIRECT SUPPORT AND GENERAL SUPPORT
MAINTENANCE MANUAL**

**MODEM RADIO TELETYPEWRITER
MD-522A/GRC
(NSN 5815-00-919-4800)**

REPORTING OF ERRORS AND RECOMMENDING IMPROVEMENTS

You can help improve this manual. If you find any mistakes or if you know of a way to improve the procedures, please let us know. Mail your letter, DA Form 2028 (Recommended Changes to Publications and Blank Forms), or DA Form 2028-2 located in the back of this manual direct to: Commander, US Army Communications-Electronics Command and Fort Monmouth, ATTN: DRSEL-ME-MP, Fort Monmouth, New Jersey 07703. In either case, a reply will be sent to you.

	PAGE
CHAPTER 1. INTRODUCTION.....	1-3
Section I. General Information.....	1-3
II. <u>Equipment Description and Data</u>	1-4
III. <u>Technical Principles of Operation</u>	1-5
IV. Detailed Block Diagram Analysis of Transmit Signal Paths.....	1-11
V. Detailed Block Diagram Analysis of Receive Signal Paths.....	1-18
VI. Stage Analysis, Transmit Signal Paths.....	1-24
VII. Stage Analysis, Receive Signal Paths.....	1-40
VIII. Power Supply Stage Analysis and Switching.....	1-54
IX. Metering Stage Analysis and Switching.....	1-59
CHAPTER 2. <u>DIRECT SUPPORT MAINTENANCE</u>	2-1
Section I. General Information.....	2-1
II. <u>Troubleshooting</u>	2-4
III. <u>Maintenance Procedures</u>	2-27
IV. <u>Adjustment Procedures</u>	2-33
CHAPTER 3. <u>GENERAL SUPPORT MAINTENANCE</u>	3-1
Section I. General Information.....	3-1
II. <u>Troubleshooting</u>	3-1
III. <u>Maintenance Procedures</u>	3-22
APPENDIX A. REFERENCES.....	A-1
B. EXPENDABLE SUPPLIES AND MATERIALS LIST (Not applicable)	
SUBJECT INDEX.....	INDEX-1
FOLDOUT INDEX.....	FO INDEX-1

*This manual supersedes so much of TM 11-5805-387-15-2, 6 Jun 67, as pertains to direct support and general support maintenance.

MODEM, RADIO TELETYPEWRITER MD-522A/GRC

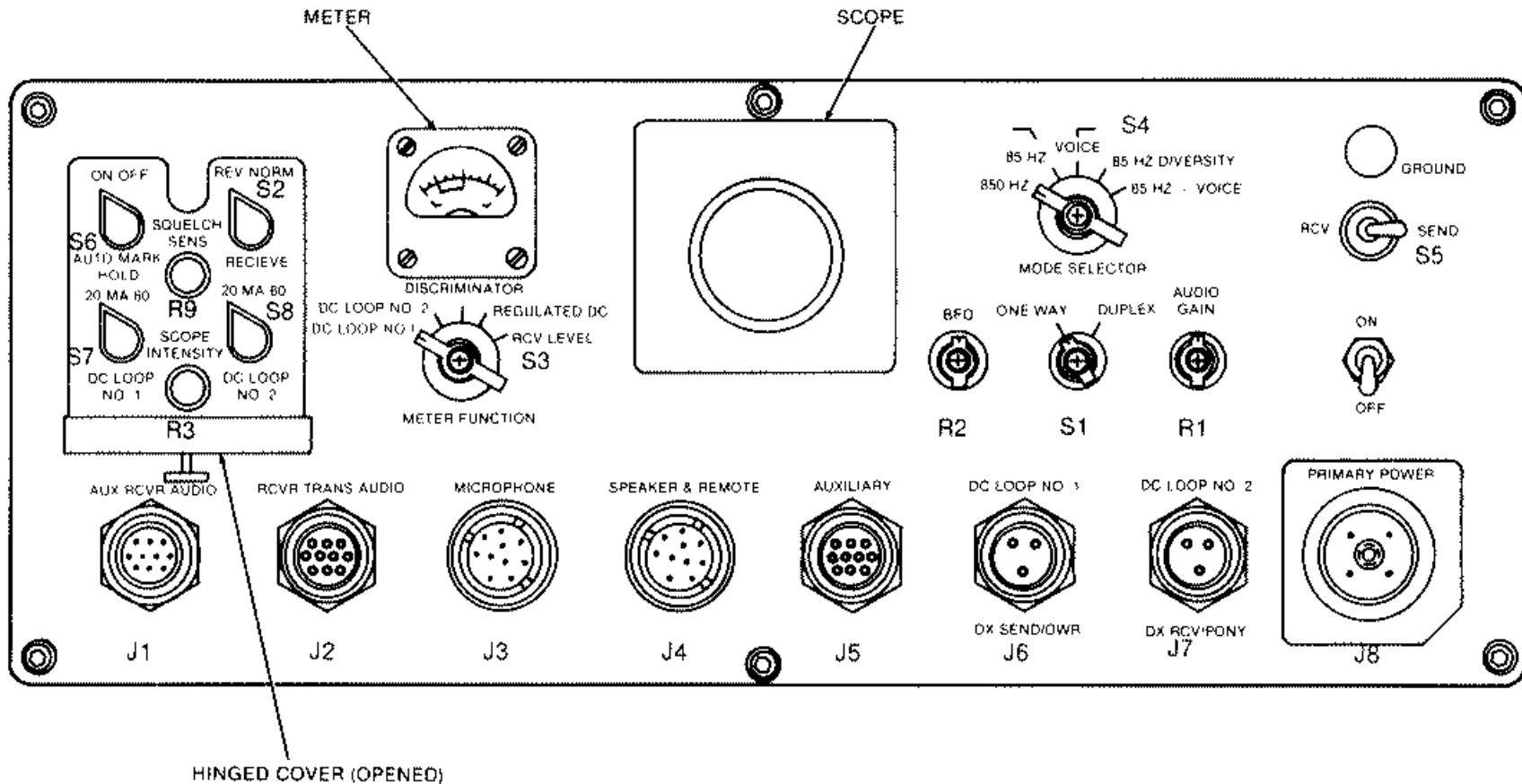

CHAPTER 1

INDEX

SECTION I

PAGE

GENERAL INFORMATION

Scope	1-3
Consolidated Index of Army Publications and Blank Forms.....	
Maintenance Forms, Records, and Reports.....	1-3
Destruction of Army Electronics Materiel.....	1-3
Administrative Storage.....	
Reporting Equipment Improvement Recommendations.....	1-3
Technical Characteristics	1-3

SECTION II

EQUIPMENT DESCRIPTION AND DATA

Purpose and Use.....	1-4
Location and Description of Major Components.....	1-4
Differences in Models.....	1-4
Equipment Configurations	1-4
Safety, Care, and Handling	1-4
Reference Designations and Abbreviations	1-5

SECTION III

TECHNICAL PRINCIPALS OF OPERATION

General.....	1-5
Transmit Signal Path Simplified Block Diagram	1-7
Receive Signal Path Simplified Block Diagram	1-7
Power Supply Simplified Block Diagram.....	1-10
Simplified Metering and Monitoring Circuits	1-10

SECTION IV

DETAILED BLOCK DIAGRAM ANALYSIS OF TRANSMIT SIGNAL PATHS

General.....	1-11
Send Dc Loop	1-11
Send Sensing Circuit.....	1-11
Mark-Space Tone Generation	1-12
Mixer Circuit.....	1-14
Transmit Voice Signal Path.....	1-15
Transmit Output Circuitry	1-16
Signals Produced in Transmit Signal Path	1-18

SECTION V

DETAILED BLOCK DIAGRAM ANALYSIS OF RECEIVE SIGNAL PATHS

General.....	1-18
Receive Signal Path Input.....	1-18
Receive Tty Channel 2.....	1-19
Receive Tty Channel 1.....	1-19
Receive Mark-Space Pulse Generation.....	1-20
Receive Sensing Circuit.....	1-20
Receive Dc Loop.....	1-21
Diversity Switching.....	1-22
Tty Squelch (Mark Hold) Switching.....	1-22
Voice and Tty Monitor Signal Path	1-23
Detailed Block Diagram Analysis of Scope Module	1-23

SECTION VI

STAGE ANALYSIS, TRANSMIT SIGNAL PATHS

Introduction	1-24
Loop Battery Module A5	1-24
Dc-to-Ac Inverter and Current Regulator	1-26
Receive and Send Sensing Circuit	1-28
Switching Circuits.....	1-30
Transmitter Module A3.....	1-32
Mark and Space Oscillator Output Switching.....	1-33
Mark and Space Oscillator Output Divider Circuits	1-33
Mixer Oscillator and Switching	1-35
Mixer Oscillator Output Divider Circuits.....	1-36
Sine Wave Pass Filter, Isolation Amplifier and Mixer	1-36
Mixer Amplifier and Transmit Fsk/Nsk Filter Switching.....	1-38
Transmit Voice Circuits	1-39
Output Amplifying Circuits.....	1-40

SECTION VII

STAGE ANALYSIS, RECEIVE SIGNAL PATHS

Introduction	1-40
Receive Input Isolation Amplifiers	1-40
Receive Audio Module A1	1-41
Receiver Module A4.....	1-42
Frequency Discriminator Circuits.....	1-44
Receive Mark-Space Pulse Generation, Stage Analysis.....	1-46
Diversity Switching.....	1-48
Mark Hold Switching	1-50
Scope Module A2.....	1-52
Intensity Squelching	1-53
Power Supply	1-53

SECTION VIII

POWER SUPPLY STAGE ANALYSIS AND SWITCHING

General.....	1-54
Power Input and Transient Suppressor Stage Analysis.....	1-54
+22 Volt Preregulator	1-55
Twenty-Volt Regulator.....	1-55
Operational Control Circuits	1-56
85- Hz Operation.....	1-57
Voice Operation	1-57
85 -Hz Diversity Operation	1-58
85 Hz + Voice Operation	1-58

SECTION IX

METERING STAGE ANALYSIS AND SWITCHING

General.....	1-59
Metering Circuitry.....	1-59

CHAPTER 1**INTRODUCTION**

Section I. GENERAL INFORMATION**1-1. SCOPE**

This manual describes direct and general support maintenance for Modem Radio Teletypewriter MD-522A/GRC. It includes instructions for troubleshooting, repairing, and testing the equipment. It also lists all the tools, test equipment, and materials needed for maintenance.

The modem and its major electronic components are described in section II of this chapter. Operating instructions are covered in TM 11-5805-387-10-2; organizational maintenance is covered in TM 11-5805-387-20-2.

NOTE

In this manual, Modem Radio Teletypewriter MD-522A/GRC is referred to as modem.

1-2. CONSOLIDATED INDEX OF ARMY PUBLICATIONS AND BLANK FORMS

Refer to the latest issue of DA Pam 310-1 to determine whether there are new editions, changes or additional publications pertaining to the equipment.

1-3. MAINTENANCE FORMS, RECORDS, AND REPORTS**a. Reports of Maintenance and Unsatisfactory Equipment**

Department of the Army forms and procedures used for equipment will be those prescribed by DA PAM 738-750 as contained in Maintenance Management Update.

b. Report of Packaging and Handling Deficiencies

Fill out and forward SF 364 (Report of Discrepancy (ROD)) as prescribed in AR 735-11-2/DLAR 4140.55/NAVMATINST 4355.73A/AFR 400.54/MCO 4430.3F.

c. Discrepancy in Shipment Report (DISREP) (SF 361)

Fill out and forward Discrepancy in Shipment Report (DISREP) (SF 361) as prescribed in AR 55-38/NAVSUPINST 4610.33C/AFR 75.18/MCO P4610.19D/DLAR 4500.15.

1-4. DESTRUCTION OF ARMY ELECTRONICS MATERIEL

Destruction of Army electronics materiel to prevent enemy use shall be in accordance with TM 750-244-2.

1-5. ADMINISTRATIVE STORAGE

Administrative Storage of Equipment issued to and used by Army activities will have preventive maintenance performed in accordance with the PMCS charts before storing. When removing the equipment from administrative storage the PMCS should be performed to assure operational readiness. Disassembly and repacking of equipment for shipment or limited storage are covered in TM 740-90-1, Administrative Storage of Equipment.

1-6. REPORTING EQUIPMENT IMPROVEMENT RECOMMENDATIONS (EIR)

If your modem needs improvement, let us know. Send us an EIR. You, the user, are the only one who can tell us what you don't like about your equipment. Let us know why you don't like the design. Tell us why a procedure is hard to perform. Put it on an SF 368 (Quality Deficiency Report). Mail it to us at: Commander, US Army Communications-Electronics Command and Fort Monmouth, ATTN: DRSEL-ME-MP, Fort Monmouth, New Jersey 07703. We'll send you a reply.

1-7. TECHNICAL CHARACTERISTICS

See TM 11-5805-387-10-2.

Section II. EQUIPMENT DESCRIPTION AND DATA

1-8. PURPOSE AND USE

PURPOSE:

- Provides single channel, one-way reversible, or duplex communication in line with radio transmitters and receivers.
- Converts dc mark and spaced pulses into audio tones.
- Converts audio tones into dc mark and space pulses.

USE:

- Used with any standard teletypewriter equipment using 20-or 60-milliampere inputs and outputs.
- Converts dc marks and spaces to audio tones that modulate radio transmitters for signal transmission to distant stations.
- Converts signal received from distant transmitters into marks and spaces for printing on a teletypewriter.

NOTE

Signals received and transmitted are frequency-shift-keyed (fsk), radio frequency (rf) signals.

1-9. LOCATION AND DESCRIPTION OF MAJOR COMPONENTS

See TM 11-5805-387-10-2.

1-10. DIFFERENCE IN MODELS

There are several physical and electronic differences between this modem and Modem Radio Teletypewriter MD-522/GRC. For a complete description of MD-522/GRC, see TM 11-5805-387-10-1.

1-11. EQUIPMENT CONFIGURATIONS

The modem is always used as a component of a radio teletypewriter system. The modem's function in a radio teletypewriter system in shelters AN/GRC-142 and AN/GRC-122 is described in TM 11-5815-334-12.

1-12. SAFETY, CARE, AND HANDLING

Safety instructions are on the warning page found inside the manual 6 front cover.

Be very careful when cabling the modem. Connectors and cable assemblies are keyed for easy installation. The equipment may be damaged if cable assemblies are not properly aligned.

Carry the modem by both handles at all times, even though it is lightweight.

Read all warnings, cautions, and notes. Think safety!

1-13. REFERENCE DESIGNATIONS AND ABBREVIATIONS

Assembly numbers identify the modem's modules and subassemblies.

- A1 Receive audio module
- A2 Scope module
- A3 Transmitter module
- A4 Receiver module
- A5 Loop battery module
- A6 Signal filter subassembly
- A7 Meter bias subassembly
- A8 Loop connectors filter subassembly
- A9 Preregulator subassembly

Similar designators identify module subassemblies:

EXAMPLE: Subassembly A2 of transmitter module A3 is designated A3A2.

Abbreviations of component and subassembly parts complete the full reference designation:

EXAMPLE: Capacitor C1 on subassembly A3A2 is designated A3A2C1.

Section III. TECHNICAL PRINCIPLES OF OPERATION

1-14. GENERAL

The modem consists of a transmit signal path, a receive path, and an associated metering and power supply circuitry.

When the modem is set up for transmit operation, it converts dc mark and space pulses produced by tty equipment into mark and space tones, which can be transmitted by radio, or over landlines. In voice modes of transmit operation, the modem combines voice signals with tty (mark and space) tones for simultaneous transmission. The simplified transmit block diagram is discussed in paragraph 1-15.

When the modem is set up for receive operation, receive mark and space tones are converted into mark and space pulses suitable for operating receive tty equipment. In voice modes of receive operation, the modem separates voice signals from tty tones so that simultaneous reception of tty and voice messages is possible. The simplified receive block diagram is discussed in paragraph 1-16.

The power supply consists of a preregulator, a regulator, and various dc-to-dc inverters that are required to produce the currents and voltages necessary for operation of the modem. The power supply simplified block diagram is discussed in paragraph 1-17.

Metering and monitoring is accomplished by a front panel meter, a scope, and aural monitoring through headphones or a monitor speaker. Metering circuitry is discussed in paragraph 1-18.

TRANSMIT SIGNAL PATH

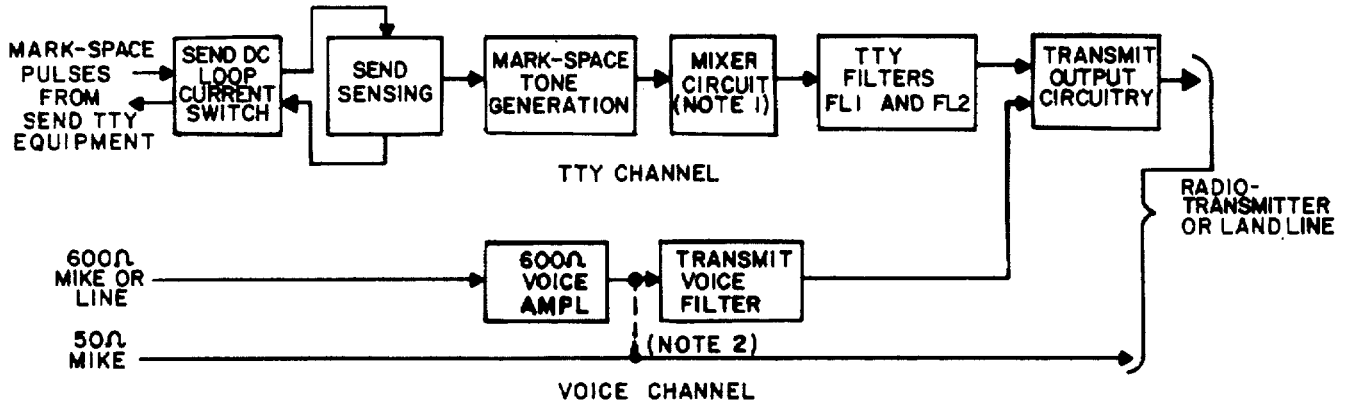

NOTES

1. MIXER CIRCUIT ESTABLISHES CENTER FREQUENCY IN 850-HZ AND 85-HZ DIVERSITY MODES. MIXER CIRCUIT IS BYPASSED IN 85-HZ AND 85-HZ + VOICE MODES.
2. IN 85-HZ + VOICE, 50W MIKE IS ROUTED THROUGH TRANSMIT VOICE FILTER TO TRANSMIT OUTPUT CIRCUITRY.

1-15. TRANSMIT SIGNAL PATH SIMPLIFIED BLOCK DIAGRAM

The transmit signal path consists of two channels; a tty channel, which converts mark and space dc pulses into mark-space (tty) tones, and a voice channel, which processes voice signals for transmission alone or in combination with tty tones.

Transmit Tty Channel. The transmit tty channel consists of a send dc loop, a send sensing circuit, mark-space tone generation circuitry, a mixer circuit, mixer tty filter, and transmit output circuitry. The send dc loop provides a current supply, or routes an externally supplied current to send tty equipment that is connected in series with the send dc loop. When the send tty equipment is keyed, loop current flows for a mark pulse and does not flow for a space pulse, resulting in a time synchronized dc pulse input to the send sensing circuit. The send sensing circuit isolates the send dc loop from the rest of the modem and produces a pulse of the proper shape and magnitude to trigger the mark-space tone generation circuitry. When the send sensing circuit applies a positive pulse to the mark-space tone generation circuitry, a mark tone is produced; when no pulse is applied to the tone generation circuitry, a space tone is produced. The tones produced by the mark-space tone generation circuitry are not of the frequency at which they will be transmitted; the tones are frequency divided, and in 850 Hz, and 85-Hz diversity are subtractively mixed in a mixer circuit to establish the center frequency. After leaving the mixer circuit, the tty mark and space tones are at the proper frequency for transmission. The tones are filtered to remove mixing harmonics and are applied to the transmit output circuitry where they are amplified, and applied through the modem RCVR TRANS AUDIO jack to the associated radio transmitter or landline.

Transmit Voice Channel. The transmit voice channel has a 50-ohm microphone (mike) input, and a 600-ohm input for mike or line. The voice channel is operative only in the 85 Hz + voice mode and the voice mode.

- In the 85 Hz + voice mode, the 600-ohm voice input is amplified by the 600-ohm voice amplifier and applied to a transmit voice filter. The 50-ohm mike input is applied direct to the transmit voice filter. The transmit voice filter limits the bandwidth of the voice signal to enable the upper portion of the radio transmitter sidebands to be used for tty tones. The output of the transmit voice filter is applied to the transmit output circuitry, where it is combined with tty tones generated in the transmit tty channel to produce the composite tty and voice transmission.
- In the voice mode, no tty information is transmitted, so the transmit voice filter is bypassed. The 600-ohm voice input is amplified by the 600-ohm voice amplifier and is applied direct to the transmit output circuitry. The transmit output circuitry further amplifies the 600-ohm voice signal, which is then applied through the modem RCVR TRANS AUDIO jack to the associated radio transmitter or landline. In the voice mode, the 50-ohm mike input is routed through the modem for switching purposes. The switched 50-ohm mike input is applied through the modem RCVR TRANS AUDIO jack to the associated radio transmitter or landline.

1-16. RECEIVE SIGNAL PATH SIMPLIFIED BLOCK DIAGRAM (fig. FO-3)

The receive signal path consists of two main channels: a tty channel which converts mark and space tones into mark and space pulses for operation of tty machines, and a voice channel which separates voice signals from tty tones and amplifies the voice for loudspeaker or headset.

Receive Tty Channel. The receive tty channel consists of an isolation amplifier, an input filter, a mixer, diversity switching circuitry, two frequency discriminators, mark-space pulse generation circuitry, a receive sensing circuit, a loop current switch dc supply. Tty tones from the associated radio receiver or landline are applied to the tty channel isolation amplifier, which prevents interaction between tty and voice channels and provides a constant input impedance. At the output of the input filter, the receive tty channel is split into two channels, designated tty channel 1 and tty channel 2. (In the 850-Hz mode, tty channel 1 begins before the input filter; wideband noise and mixing harmonics are filtered after the mixer.)

- **Tty channel 1.** Tty channel 1 functions in 850-Hz and 85-Hz diversity modes to process 2,000-Hz fsk and 425-Hz nsk tty tones, respectively. The 2,000-Hz fsk or 425-Hz nsk tones are fed to a mixer, which recenters them to 2,805-Hz nsk. The centered tty tones are fed to the nsk fsk frequency discriminator, which puts out a dc voltage of one polarity for a mark tone input, and a dc voltage of the opposite polarity for a space tone input. Investigation of tty channel 2 will be made before continuing through the tty receiver path.
- **Tty channel 2.** Tty channel 2 functions in all 85-Hz modes (including diversity) to process received nsk tty tones centered about 2,805 Hz. The 2,805-Hz nsk is fed directly to the nsk only frequency discriminator, which puts out a dc voltage of one polarity for a mark tone input, and the opposite polarity for a space tone input.
- **Tty receive path, reunited.** The outputs of tty channels 1 and 2 are joined at the input of the mark-space pulse generation circuitry. Combination of the output voltages of tty channels 1 and 2 does not occur. In all modes but 85-Hz diversity, only one tty channel is operative; in 85-Hz diversity, diversity switching grounds the weaker channel. The mark-space pulse generation circuitry shapes the output of the frequency discriminator into a neat square wave for driving the receive sensing circuitry. The receive sensing circuitry isolates the receive dc loop from the rest of the modem and produces a pulse of proper shape and magnitude to operate the loop current switch. The loop current switch controls current supplied by the receive dc supply. The loop current switch is biased on for a mark tone input to the modem, and off for a space tone input. Thus, receive dc loop current flows for a mark tone input, and does not flow for a space tone input, keying the receive tty equipment that is connected in series with the rest of the receive dc loop.

Receive Voice Channel. The receive voice channel consists of an isolation amplifier, receive voice filter FL5, and a receive audio amplifier. Voice, or 2,805-Hz nsk combined with voice is applied to the modem voice input isolation amplifier from the associated radio receiver or landlines. The voice input isolation amplifier, in conjunction with the tty channel isolation amplifier, prevents interaction between tty and voice channels. In 85-Hz plus voice mode, the output of the voice channel isolation amplifier is applied to receive voice filter FL5, which filters out 2,805-Hz nsk tty tones. The filtered signal, now consisting of voice only, is amplified by the receive audio amplifier and applied to a monitor speaker or headset. In all other modes, the unfiltered output of the voice channel isolation amplifier supplied directly to the receive audio amplifier permits monitoring of voice circuits, or tty tones.

POWER SUPPLY

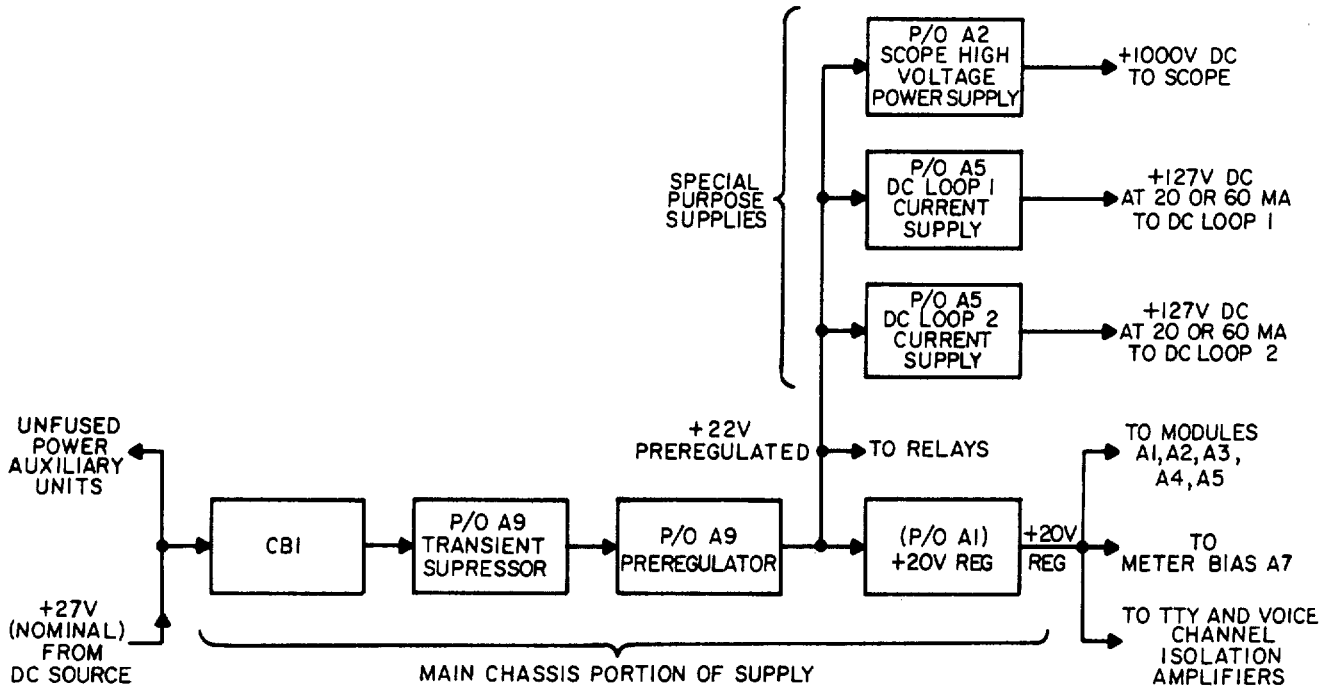

1-17. POWER SUPPLY SIMPLIFIED BLOCK DIAGRAM

The power supply circuitry in the modem may be divided into two main categories: the main chassis power supply and the special purpose supplies that are located in scope module A2 and loop battery module A5. The power supply circuitry in the modem consists of circuit breaker CB1, a transient suppressor, a preregulator, a +20 volt regulator, a scope high-voltage power supply, and two dc loop current supplies. The power supply circuits convert an unregulated input of a nominal +27 volts dc into a transient-protected, regulated +22 and +20 volt dc supply for operation of the modem circuitry. Unfused, unprotected +27 volts dc (nominal) is available to auxiliary equipment by an internal connection in the modem.

Main Chassis Portion of Power Supply. Circuit breaker CB1 serves as an on-off switch and protects against long-term overloads. The +27 volt (nominal) input is applied to the transient suppressor, which protects semiconductor components against damage from short duration high-voltage spikes caused by switching transients from other units connected to the common +27 volt source. The transient-protected +27 volts is applied to a preregulator. The preregulated +22 volt output operates relays, powers the special purpose power supplies in the A2 and A5 modules, and operates the +20 volt regulator, located in receive audio module A1. The +20 volt regulator in turn supplies power to the five modules (A1 through A5) plus meter bias board A7 and the input isolation amplifiers, also located on board A7.

Special Purpose Power Supplies. The scope high-voltage power supply converts the preregulated +22 volts dc into +1,000 volts dc for operation of the scope module crt. Dc loop 1 and 2 power supplies convert the preregulated +22 volts dc into a +127 volt dc power supply to supply current for dc loops 1 and 2.

1-18. SIMPLIFIED METERING AND MONITORING CIRCUITS

The operating condition of the modem can be checked with front panel meter M1, by observing the crt display, or by audio monitoring with an external monitor speaker or headphones.

Metering. Dc loop current for either loop, center frequency of the received signal centering (DISCRIMINATOR position of S3), +20 volt regulator output, and the level of the receive input to the MD-522A/GRC may be read from meter M1. The circuitry associated with the meter contains sampler resistors, bias resistors, and detector diodes necessary for proper meter readings in the various positions of METER FUNCTION switch S3.

Scope Display. Mark-space signals from the frequency discriminators in tty channel 1 or 2 are applied to scope module A2. Because of the phase relationships in the frequency discriminators, the major axes of nsk-mark and space ellipses are at an angle of 30° and the major axes of fsk-mark and space ellipses are at an angle of 90°. When the center frequency of incoming tty tones is off frequency (because of a badly tuned receiver, misadjusted beat-frequency oscillator (bfo), or off-frequency transmitted tty tones), the mark or space ellipse will reduce in size, or disappear entirely. This indicates that the incoming signal is so far off frequency that one of the tty tones cannot pass through the frequency discriminators. In diversity operation, where the stronger of two signals is selected, scope module A2 automatically switches to display the stronger signal.

Monitoring Through Speaker or Headphones. The receive audio (tty tones and/or voice) input to the modem can be monitored through headphones or speaker in all modes, except 85 Hz plus voice. In this mode, tty tones are filtered out before amplification of the voice signal.

Section IV. DETAILED BLOCK DIAGRAM ANALYSIS OF TRANSMIT SIGNAL PATHS

1-19. GENERAL

This section presents a detailed description of the function of each stage in the signal path. The first half of the transmit signal path is unaffected by the mode of operation selected by MODE SELECTOR switch S4. To understand transmit signal path operation, it is necessary to learn the various frequencies generated in transmitter module A3 and understand their functions. This is discussed in detail in the following paragraphs and summarized in paragraph 1-24.

1-20. SEND DC LOOP

The send loop is a dc circuit that contains tty send equipment in series with the send regulator power supply, internal-external switch S1, and send oscillator power supply zener diode A5VR6.

Send tty equipment, such as keyboard, transmitter-distributor, or tape reader, causes current in the send dc loop (dc loop No. 1) to flow or not flow, resulting in time synchronized mark or space pulses. The loop current can be supplied either internally or externally.

- With A5S1 set for internal power supply current, regulated current supply 1 provides the loop current. Regulated power supply current 1 consists of dc-to-ac inverter 1, bridge rectifier 1, and current regulator 1. Dc-to-ac inverter 1, consisting of A5Q3, A5Q4, and A5T2, changes + 22 volts from preregulator A9 into an ac voltage, which is rectified by diode bridge rectifier (A5A1CR7, CR8, CR9, CR10) to provide + 127 volts dc for the operation of the send loop. Send loop current is regulated by current regulator 1. Front panel DC LOOP NO. 1 switch S7 selects 20 or 60 mA regulation.
- With A5S1 set for external current supply, current supply 1 is switched out of the send dc loop, and current must be supplied from a source external to the modem. The external supply may be of either polarity, since send steering quad A5A1CR11, CR12, CR13, CR14 routes the send dc loop current so that proper polarity is maintained for the send sensing circuit. Note that the modem does not provide loop current regulation in the external position.

1-21. SEND SENSING CIRCUIT (fig. FO-4)

When current flows in dc loop No. 1, a voltage drop appears across send oscillator voltage supply zener diode A5VR6. This voltage energizes send oscillator A5A2Q4. The output of A5A2Q4 is detected by envelope detector-doubler A5A2CR15, CR16, providing positive pulse for a loop current and no pulse for no loop current. Thus, the send sensing circuit provides a shaped output of proper level for operation of following circuitry. Also, the send sensing circuitry isolates the dc loop from the rest of the modem, thus preventing interaction of grounds between equipment allocated to the dc loop and the modem.

1-22. MARK-SPACE TONE GENERATION

The mark-space generation circuitry consists of a 221.0-kHz oscillator, 227.8-kHz oscillator, switching circuitry for grounding the output of one or the other oscillator, a divide-by-8 circuit, a divide-by-10 circuit, an isolation amplifier, and a transmit REV/NORM switch for selecting reverse or normal transmit tones. Frequencies produced by mark-space generation and following circuitry are discussed in detail and summarized below.

Transmit REV/NORM Switch at NORM. With transmit REV/NORM switch set at NORM, the positive send pulse output of envelope detector-doubler A5A2CR15, CR16 is applied to phase reverse switch A3A1Q1. This causes phase reverse switch A3A1Q1 to conduct, driving its output to ground. When A3A1Q1 output is grounded (low state), 221.0-kHz switch A3A1Q2 is biased off (high state), resulting in a strong positive output. This biases 227.8-kHz switch A3A1Q3 into conduction, driving its output to ground (low state). Since the output of 227.8-kHz (space) oscillator A3A1Q2, Q22 is tied to the output of A3A1Q3, the space oscillator is grounded, biasing isolation diode A3A1CR4 into nonconduction. Consequently, the output of the ungrounded 221.0-kHz (mark) oscillator is applied through forward-biased isolation diode A3A1CR3 to shaper amplifier A3A1Q4. If no loop current flows in dc loop No. 1 corresponding to a normal space, phase reverse switch A3A1Q1 is in a high state, because no positive pulse is applied from the send sensing circuit. This biases 221.0-kHz switch A3A1Q2 to a low state, effectively grounding the output of 221.0-kHz (mark) oscillator A3A1Q19, Q20. The input to 227.8-kHz switch A3A1Q3 is also grounded, switching its output to a high state. With the 227.8-kHz switch offering a high impedance to ground, the output of A3A1Q21, Q22 is ungrounded, and is applied to shaper amplifier A3A1Q4 through isolation diode A3A1CR4. The 221.0-kHz switch, A3A1Q2, back biases A3A1CR3, isolating grounded 221.0-kHz oscillator A3A1Q19, Q20 from the shaper amplifier A3A1Q4 input.

Transmit REV/NORM Switch at REV. With transmit REV/NORM switch at REV, phase inverter switch A3A1Q1 is bypassed, reversing the operation described above. That is, current in the dc send loop causes the send sensing circuitry to produce a positive pulse, which is applied directly to 221.0-kHz switch A3A1Q2. The positive pulse switches A3A1Q2 to a low state, grounding the output of the 221.0-kHz (mark) oscillator, back biasing isolation diode A3A1CR3, and switching A3A1Q3 to a high state. With A3A1Q3 in a high state, the 227.8-kHz (space) oscillator feeds shaper amplifier A3A1Q4. Thus, with transmit REV/NORM switch at REV, a current in the dc send loop generates a normal space tone (rather than the normal mark tone produced for a setting of NORM). Similarly, with the switch at REV, no dc loop current will produce a normal mark tone (reverse space).

Frequency Division of Mark and Space Tones. Mark-space frequency division circuitry consists of shaper amplifier 04, divide-by-8 multivibrators A3A1Q5 through Q10; divide-by-10 multivibrators A3A1Q11 through Q18; sine wave pass filter A3A2C1, C2, L1; and isolation amplifier A3A2Q1. The mark-space frequency division circuitry divides the mark or space tone by 8 for fsk modes and by 80 for nsk modes.

- **Fsk operation.** The mark or space tone provided by the 221.0 or 227.8-kHz oscillator is applied through the proper isolation diode to amplifier A3A1Q4, which shapes the oscillator output to approximate a square wave for the input to divide-by-8 circuit. The divide-by-8 circuit consists of three series-connected, divide-by-2 bistable multivibrators. The square wave output of the divide-by-8 circuit is applied direct to sine wave pass filter A3A2C1, C2, L1, which blocks the high-frequency components of the square wave, so that the output of the sine wave pass filter is essentially a sine wave. (Capacitor C1 is switched out of the filter to widen the bandwidth for fsk operation.) The MODE SELECTOR switch removes power from divide-by-10 circuitry A3A1Q11 through Q18 so this portion of the frequency divider chain does not operate in the 850-Hz mode (fsk). The output of the sine wave pass filter is fed to isolation amplifier Q1, which recovers filter losses and stabilizes load and source impedances. At this point, a mark is 27,625 Hz and a space is 28,475 Hz. Additional processing of these tones is necessary to produce the required 2,000-Hz fsk mark-space tones.

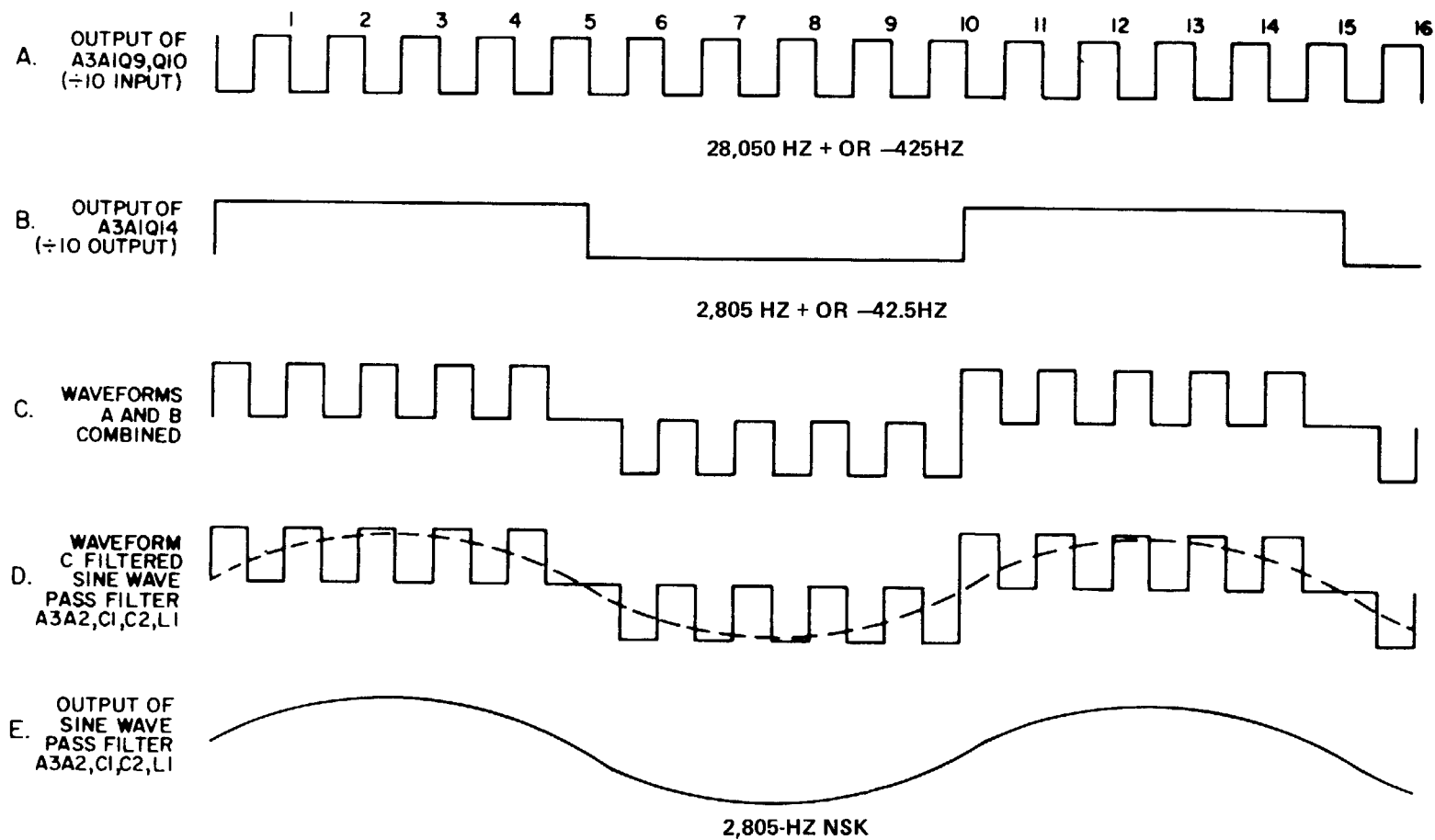

TRANSMITTER MODULE A3, 2,805-HZ NSK GENERATION

- **Nsk operation.** Shaper amplifier A3A1Q4 and divide-by-8 circuit A3A1Q5 through Q10 operates as described in fsk operation. The divide-by-8 output is applied direct to sine wave pass filter A3A1C1, C2, L1 as before, with C1 switched in to modify the pass band width for nsk operation. However, the divide-by-8 output (A) is also divided by 10 (A3A1Q11 through Q18), resulting in a divide-by-80 output (B). The divide-by-80 output is also applied to sine wave pass filter A3A1C1, C2, L1 where it is combined with the divide-by-8 output (C). The resulting waveform is applied to sine wave pass filter A3A2C1, C2, L1, which acts to round off the applied square wave into a sine wave (D, dotted line). At this point, a mark tone is 2,762.5 Hz and a space tone is 2,847.5 Hz, the frequencies of the 2,805-Hz nsk mark and space tones. The output of the sine wave pass filter is fed to isolation amplifier A3A2Q1, which stabilizes load and source impedances. The 2,805-Hz nsk produced is used for 85 Hz, 85 Hz + voice, and the higher diversity channel. The production of the lower diversity channel (425-Hz nsk) is discussed in paragraph 1-23.

1-23. MIXER CIRCUIT (fig FO-4)

The mixer circuit mixes certain mark and space tones with BFO mixer injection frequencies to establish the center frequency for the tones of the 850-Hz mode and the lower band of 85 Hz diversity operation (2,000-Hz fsk and 425-Hz nsk, respectively). The center frequency of the 2,805-Hz nsk mark and space tones (85-Hz modes) has been established (para 1-22), and consequently bypasses the mixer circuit. The mixer circuit consists of mixer oscillator A3A2Q3, Q4; divide-by-10 integrated circuit A3A2Z1 and its driver amplifier A3A2Q5; mixer A3A2T1, CR1, CR2; divide-by-10 bypass switch diode A3A2CR10, and mixer filters FL1 and FL2. The mixer circuit operates only in the 850-HZ and 85-HZ DIVERSITY settings of the MODE SELECTOR switch.

Mixer Circuit in 850-Hz Mode Operation. With MODE SELECTOR switch S4 set at 850 HZ, crystal A3A2Y2 controls the frequency of mixer injection oscillator A2A3Q3, Q4 to produce an output of 26,050 Hz. In the 850-Hz mode, the divide-by-10 integrated circuit is not energized, and diode CR10 is forward biased. The 26,050-Hz mixer injection frequency is applied to mixer A3A2T1, CR1, CR2 where it is combined with the output of isolation amplifier A3A2Q1. The output of isolation amplifier A3A2Q1 is 27,625 Hz for a mark and 28,475 Hz for a space. When subtractively combined with the mixer injection frequency in mixer A3A2T1, CR1, CR2, a mark tone becomes 1575 Hz, and a space becomes 2425 Hz. The mark and space tones are centered ± 425 (850-Hz frequency shift) around 2,000 Hz. Also the 2,000-Hz tone actually does not exist, but is used as a convenient method of expressing the frequencies of mark and space tones. The 2,000-Hz fsk tones are amplified by mixer amplifier A3A2Q2. The output of mixer amplifier A3A2Q2 is applied to switches A3A2CR3 and CR4. In the 850-Hz mode, switch A3A2CR4 is biased on, so the output of mixer amplifier A3A2Q2 is applied to 2,000-Hz nsk filter FL2. Filter FL2 filters out mixing harmonics, and applies the filtered 2,000-Hz fsk tones to the transmit output circuitry.

Mixer Circuit in 85-Hz Diversity Mode of Operation. With the MODE SELECTOR switch set at 85 HZ DIVERSITY, crystal A3A2Y1 controls the frequency of mixer oscillator A3A2Q3, Q4 to produce an output of 23,800 Hz. In the 85-Hz diversity mode, the divide-by-10 driver A3A2Q5 and divide-by-10 integrated circuit A3A2Z1 are energized. (Divide-by-10 bypass switch A3A2CR10, which bypasses the divide-by-10 circuitry, is backbiased in 85-Hz diversity.) The 2,380-Hz output of divide-by-10 integrated circuit A3A2Z1 is the mixer injection frequency applied to mixer A3A2T1, CR1, CR2. In the mixer, the mixer injection frequency is combined with the output of isolation amplifier A3A2Q1. As explained in paragraph 1-22, the output of isolation amplifier A3A2Q1 is 2,805-Hz nsk (2,762.5 Hz for a mark, 2,847.5 Hz for a space). When subtractively combined with the 2,380-Hz mixer injection frequency in mixer A3A2T1, CR1, CR2, a mark tone becomes 382.5 Hz and a space becomes 467.5 Hz. The mark and space tones are centered ± 42.5 Hz (85-Hz frequency shift) around 425 Hz. The 425-Hz tone does not exist, but is used as a convenient means of expressing the frequencies of tones. The 425-Hz nsk thus produced is amplified by mixer amplifier A3A2Q2 and is applied to switches A3A2CR3 and CR4. With MODE SELECTOR switch S4 set at 85 HZ DIVERSITY, switch A3A2CR3 is biased on, so the output of mixer amplifier A3A2Q2 is applied to the 425-Hz nsk portion of FL1. Filter FL1 filters out mixing harmonics, and applies the filtered 425-Hz nsk tones to the transmit output circuitry. The 2,380 Hz produced by divide-by-10 integrated circuit A3A2Z1 is also applied to the receiver module for mixer injection.

Mixer Circuit in 85-Hz, 85-Hz + Voice, and Voice Modes of Operation. Mixing occurs only in 850Hz and 85-Hz diversity modes. In all other tty modes (85-Hz and 85-Hz voice), mixer A3A2T1, CR1, CR2 is bypassed, and isolation amplifier A3A2Q1 applies the 2,805-Hz nsk tones to the 2,805-Hz nsk portion of FL1. Filter FL1 filters out mixing harmonics, and applies the filtered 2,805-Hz nsk tones to the transmit output circuitry.

1-24. TRANSMIT VOICE SIGNAL PATH (fig FO-4)

The transmit voice signal path consists of a 50-ohm (nominal) impedance signal path and a 600-ohm (nominal) signal path.

50-Ohm Voice Signal Path. The 50-ohm voice signal path processes voice audio produced by a carbon handset or microphone. The signal path consists of 50-ohm mike filter A6L6, C6, C13; 50-ohm mike bias supply A3A2R38; a keyline, and 50-ohm MIKE LEVEL control A3A2R40; 50-ohm mike keying switch A3A2CR8; transmit voice filter FL3; voice filter amplifier A3A2Q9; and 50-ohm mike output filter A6L6, C6, C11. The 50-ohm voice signal path is switched by the MODE SELECTOR switch. Operation in the 85-Hz plus voice modes is described below.

- **85-Hz plus voice mode operation of 50-ohm voice signal path.** In the 85-Hz plus voice mode, the modem supplies dc bias for the 50-ohm mike, switches, filters, and keys; controls the level of the 50-ohm mike signal; and mixes the signal with tty tones produced and processed in the tty signal path. Voice signals generated in the 50-ohm mike are applied through MICROPHONE input jack J3 to input filter A6L3, C3, C13. Resistor A3A2R40 controls the level of the applied signal and insures proper balance between voice signals that originates from a 50-ohm source and tty tones. When the 50-ohm mike is switched on, the keyline is grounded through pin F of MICROPHONE J3 (or SPEAKER + REMOTE J4, or AUXILIARY J5). This forward biases 50-ohm mike keying switch A3A2CR8, applying the signal through isolation resistor A3A1 R46 to transmit voice filter FL3. Filter FL3 establishes a voice bandwidth of 200-to 2,260 Hz, preventing interference with the 2,805-Hz nsk tones when voice is combined with tty tones in the transmit output section. The output of FL3 is applied to the transmit output section.

- Voice mode operation of 50-ohm voice signal path. In the voice mode, the modem filters and switches voice signals, but does not operate on the signal in any other way. Keying level control and mike bias must be supplied externally. Voice signals generated in the 50-ohm mike are applied through MICROPHONE input jack J3 to input filter A6L6, C6, C13, through wafer S4B of MODE SELECTOR switch S4 to 50-ohm mike output filter A6L3, C3, C11. The signal then passes out of the modem through RCVR TRANS AUDIO jack J2. Transmit voice filter FL3 is not used in this mode.

1-25. TRANSMIT OUTPUT CIRCUITRY (fig FO-4)

The transmit output circuitry consists of tty amplifier A3A2Q6, voice filter amplifier A3A2Q9, 600-ohm voice amplifier A3A2Q8 (voice mode only), transmit output amplifier A3A2Q7, and transmit output transformer A6T1. Tty amplifier A3A2Q6, voice filter amplifier A3A2Q9, and 600-ohm voice amplifier A3A2Q8 feed a common buss through their respective isolation resistors.

The buss is the input to transmit output amplifier A3A2Q7. In 85-Hz plus voice mode, the 600-ohm or 50-ohm voice signal output of transmit voice filter FL3 is applied to voice filter amplifier A3A2Q9, which serves to recover filter losses and to isolate the voice and tty signal paths. Filter FL3 limits the voice bandwidth to 2,260 Hz, preventing interference with 2,805-Hz nsk tty tones that are applied to the buss through tty amplified A3A2Q6. Thus, mixing of voice signals and tty tones occurs at the input to transmit output amplifier A3A2Q7. In all other modes, no mixing is necessary, and voice (only) or tty tones (only) are applied to the transmit output amplifier. The unbalanced output of transmit output amplifier A3A2Q7 is applied to transmit output transformer A6T1, which provides a balanced 600-ohm nominal output at RCVR TRANS AUDIO jack J2. A 50-ohm nominal output is also provided through J2 in voice mode only.

TRANSMITTER FREQUENCIES

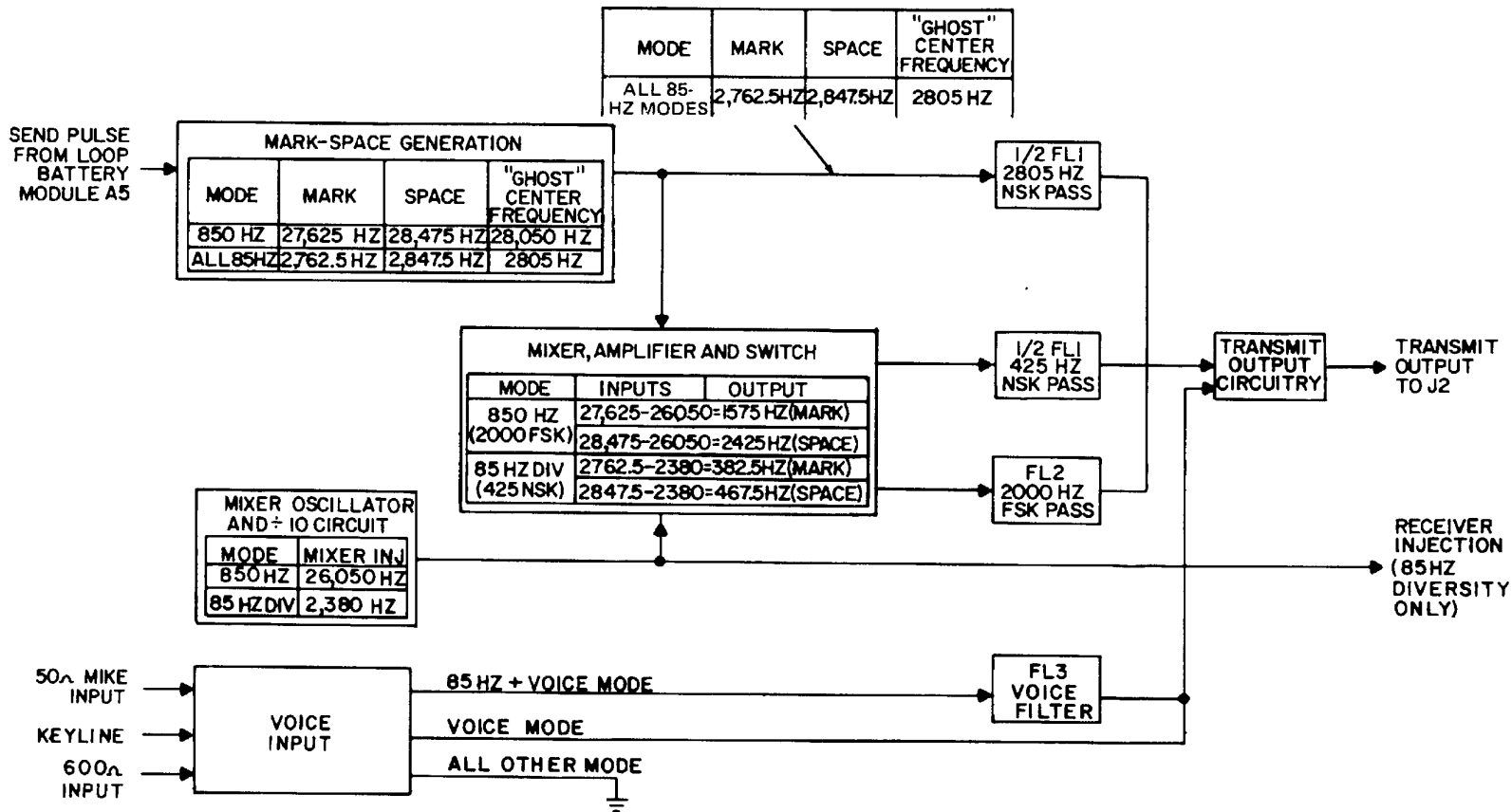

NOTES:

1. "GHOST" CENTER FREQUENCY NEVER EXISTS IN THE CIRCUIT, HOWEVER MARK AND SPACE TONES APPEAR TO CENTER ABOUT IT.
2. NORMAL MARK AND SPACE FREQUENCIES ARE SHOWN. THE FREQUENCY FOR A REVERSE MARK IS THAT FOR NORMAL AND VICE VERSA.

1-26. SIGNALS PRODUCED IN TRANSMIT SIGNAL PATH

The preceding figure shows the various frequencies produced by the transmitter module for use in the transmit signal path. The blocks, representing circuits, correspond to similar blocks in the transmit signal path detailed block diagram (fig. FO-4). Within the blocks are tables that show the output of that circuitry as a function of the setting of the MODE SELECTOR switch. Signals are produced in mark-space generation circuitry and in the mixer oscillator (para 1-22, 1-23) for combination in the mixer and application to filters and transmit output circuitry. The frequencies subtractively mixed are shown within the mixer, amplifier, and switch block. In 85-Hz modes, the output of the mark-space generation is applied direct to the 2,805-Hz section of FL1; in 85-Hz diversity, it is also mixed in the mixer section to obtain a 425-Hz nsk signal. Also, the mixer oscillator supplies receiver module A4 mixer injection in 85-Hz diversity.

Section V. DETAILED BLOCK DIAGRAM ANALYSIS OF RECEIVE SIGNAL PATHS

1-27. GENERAL

A simplified description of the receive signal path is given in paragraph 1-16. This section contains a detailed description of the function of each stage in the signal path. (Description of the functions of components within each stage is covered in section VIII.) The receive signal path consists of two main branches: a tty signal path, which converts mark and space tones into mark and space pulses for operation of tty machines, and a voice and tty monitor signal path, which separates voice signals from tty tones and amplifies the voice (or tty tones in all modes but 85 Hz + voice) for loudspeaker or headset.

1-28. RECEIVE SIGNAL PATH INPUT (fig. FO-5, fig. FO-6)

The receive signal path input consists of audio tty tones and/or voice received by radio, or over landlines. In one-way operation, only one radio transmitter or landline is required; but in duplex operation, the simultaneous transception of signals requires an auxiliary receiver or second landline for reception, so that the other may be used for transmission. ONE/WAY DUPLEX switch S1 is used to select the source of the audio input to the modem. The input signals are applied simultaneously to identical isolation amplifiers, one for the tty channel and the second for a voice channel. The isolation amplifier provides a constant input impedance and, prevents interaction between signals of the tty signal path, and the voice signal path. The output of tty channel isolation amplifier A7Q1 is applied to MODE SELECTOR switch S4D, which divides the signal path into four paths; one is for all settings of S4D involving 85-Hz modes. The 2,805-Hz nsk tty tones are passed through the 2,805Hz nsk pass section of FL4, and applied to tty channel 2. In 85-Hz diversity, the input signal also contains 425-Hz nsk tones. The 425-Hz nsk tones are passed through the 425-Hz nsk pass section of FL4 and applied to tty channel 1. The third signal path provided by MODE SELECTOR switch S4D is for 2,000-Hz fsk signals in the 850-Hz mode. This path bypasses FL4, and is applied direct to the input of tty channel 1. The fourth signal path grounds the output of tty channel isolation amplifier A7Q1 in voice mode. Discussion of receive tty channel 2 (para 1-29) precedes that of the tty channel 1 (para 1-30) because the operation of channel 2 is more easily understood.

1-29. RECEIVE TTY CHANNEL 2 (fig. FO-5)

Receive tty channel 2 consists of the 2,805-Hz nsk pass portion of FL4, amplifier A4A262, limiter amplifier A4A2Q5, discriminator driver A4A2Q6, and nsk frequency discriminator A4A2T1, Q7, Q8. Filtered 2,805-Hz nsk tones, with wideband noise removed, are amplified by A4A2Q2 and applied to limiter amplifier A4A2Q5, which controls the level of the signal applied to discriminator driver A4A2Q6. The limiting action insures proper function of frequency discriminator A4A2Q7, Q8 by providing an input of constant amplitude at all times. The 2,805-Hz nsk signal consists entirely of a 2,762.5-Hz tone and a 2,847.5-Hz space tone. The frequency discriminator puts out a dc voltage of one polarity for a 2,762.5-Hz input and the opposite polarity for a 2,847.5-Hz input. The ellipses seen on the scope pattern are derived from varying phases within the discriminator. The operation of the scope module is discussed in detail in paragraph 1-37.

1-30. RECEIVE TTY CHANNEL 1 (fig. FO-5)

Receive tty channel 1 consists of mixer A4A1CR1, CR2, T1, mixer injector amplifier A4A1Q1, relay K1, nsk mixer filter FL6, fsk mixer filter FL7, amplifier A4A1Q2, limiter amplifier A4A1Q3, discriminator driver A4A1Q4, relay A4A1K1, and fsk/nsk frequency discriminator A4A1T2, Q9, Q10. Receive tty channel 1 is used only in 85-Hz diversity and 850-Hz modes.

Receive Tty Channel 1 in 85-Hz Diversity. Filtered 425-Hz nsk tones with wideband noise removed are applied to mixer A4A1CR1, CR2, T1, where they are additively mixed with 2,380 Hz from mixer injection amplifier A4A1Q1. The resulting 2,805-Hz nsk (2,380-Hz nsk + 425 nsk = 2,805-Hz nsk) is passed through the contacts of unenergized relay K1 into narrowband nsk mixer filter FL6, where mixing harmonics are removed. The 2,805-Hz nsk is then amplified by amplifier A4A1Q2, limited by limiter amplifier A4A1Q3, and applied to discriminator driver A4A1Q4, which drives fsk/nsk frequency discriminator A4A1T2, Q9, Q10 through the contacts of unenergized relay A4A1K1. Except for relay A4A1K1, the operation of the latter half of the receive tty channel 2 is identical with that of tty channel 1.

Receive Tty Channel 1 in 850 Hz. Unfiltered 2,000-Hz fsk tones are applied to mixer A4A1CR 1, CR2, T1, where they are subtractively mixed with a mixer injection frequency from bfo oscillator A1A3Q1. Using BFO control R2, the mixer injection frequency may be varied from 3,805 to 5,805 Hz, to permit reception of fsk signals with center frequencies ranging from 1,000 to 3,000 Hz. In all discussions, a 2,000-Hz center frequency is assumed. If the 2,000-Hz fsk is subtractively mixed with an assumed nominal 4,805-Hz injection frequency, a 2,805-Hz fsk output results (4,805 Hz 2,000-Hz fsk = 2,805-Hz fsk). Because the mixing is subtractive, the frequencies of the mark and space tones will be reversed at this point; the mark is the higher (3,230 Hz) and the space is the lower (2,380 Hz). Relay K1 is energized in 850 Hz; therefore, the 2,805-Hz fsk (reversed) is applied to fsk mixer filter FL7, which has a wider passband than FL6, to permit passage of fsk tones. Filter FL7 blocks mixing harmonics and wideband noise. The filtered 2,805 Hz-fsk (reversed) is amplified by amplifier A4A1Q2, limited by limiter amplifier A4A1Q3, and applied to discriminator driver A4A1Q4. In the 850-Hz mode, energized relay A4A1K1 widens the passband of fsk/nsk frequency discriminator A4A1T2, Q9, Q10 for fsk operation. Relay A4A1K1 also reverses the operation of the discriminator from nsk operation, so that the higher tone input to the discriminator (3,230 Hz) will produce a mark pulse output, and the lower tone will produce a space pulse output. The output polarity of the frequency discriminator as a function of input tty tone frequency is reversed in the 850-Hz mode. This reversal corrects the tone reversal caused by subtractive mixing in mixer A4A1CR1, CR2, T1.

1-31. RECEIVE MARK-SPACE PULSE GENERATION (fig. FO-5)

The mark-space pulse generation circuitry consists of discriminator differential amplifier A4A1Z1, dc coupled bistable multivibrator designated normal mark A4A1Q5, Q6, and ac coupled bistable multivibrator A4A1Q7, Q8. Previously discussed frequency discriminators A4A1Q9, Q10 and A4A2Q7, Q8 could be included in this listing also. The output of either tty channel 1 and/or tty channel 2 is applied to discriminator differential amplifier A4A1Z1. The signal applied to A4A1Z1 is of one polarity for a modem mark tone input, and of the other polarity for a modem space tone input; with no input to the modem, the differential output of the frequency discriminators is 0 volt. With respect to ground, the frequency discriminator output is a pulsating dc. Discriminator differential amplifier A4A1Z1 converts the analog input to a pulse (digital) output to drive dc-coupled bistable multivibrator A4A1Q5, Q6. Multivibrator A4A1Q5, Q6 serves as a buffer, isolating A4A1Z1 from following circuitry, and converting the varying dc input to an approximation of a square wave output. The output of dc-coupled bistable multivibrator A4A1Q5, Q6 drives ac-coupled bistable multivibrator A4A1Q7, Q8. The output of the frequency discriminators is balanced and floating. One side of this balanced dc signal path has been designated to normal mark buss, the other reverse mark buss.

Operation of Mark-Space Pulse Generation Circuitry for Mark Tone input to Modem. The inputs to discriminator differential amplifier A4A1Z1 are labeled A (normal mark buss) and B (reverse mark buss). The outputs are labeled C and D. When A is negative with respect to B, corresponding to a normal mark tone input to the modem, the voltage of C with respect to D rises, switching output E of dc-coupled bistable multivibrator A4A1Q5, Q6 into a low state. This in turn switches output G of the ac-coupled bistable multivibrator into a high state, and output H into a low state. If RECEIVE switch S2 is at NORM, a positive pulse corresponding to a normal mark is applied to the receive sensing circuitry. If S2 is set at REV, ground is applied to the receive sensing circuitry, corresponding to a reverse mark. Thus, if the mark tone has been transmitted higher than the space tone, correction can be made at this point for proper printout on the attached receive tty equipment.

Operation of Mark-Space Pulse Generation Circuitry for Space Tone Input to Modem. When the A input to A4A1Z1 is positive with respect to B, corresponding to a normal space tone, the voltage of C with respect to D falls, switching the output E of dc-coupled bistable multivibrator A4A1Q5, Q6 into a high state. This in turn switches output G of the ac-coupled bistable multivibrator into a low state, and output H into a high state. If RECEIVE switch S2 is at NORM a ground is applied to the receive sensing circuitry, corresponding to a normal space. If S2 is set at REV, a positive voltage is applied to the receive sensing circuitry, corresponding to a reverse space. Thus, compensation can be made at this point for mark-space tones which may have been transmitted in reverse relationship by properly setting S2.

1-32. RECEIVE SENSING CIRCUIT (fig. FO-5, fig. FO-6)

The receive sensing circuit consists of receive oscillator A5A2Q2, T2, envelope detector-doubles A5A2CR5, CR6, and loop current switch A5A2Q1. The receive sensing circuitry isolates the previously discussed stages of the receive tty signal path from the external dc loops, preventing interaction of grounds between equipment attached to the dc loop and the modem. The output of the mark-space pulse generation circuitry is applied to the receive sensing circuitry through RECEIVE switch S2. A positive pulse, corresponding to a normal mark, or a reverse space gates receive oscillator A5A2Q2, T2 on. The output of A5A2Q2, T2 is detected by envelope detector-doubler A5A2CR5, CR6, which causes loop current switch A5A2Q1 to conduct. When ground is applied to the receive oscillator, there is no output; therefore, loop current switch A5A2Q1 is biased into nonconduction.

1-33. RECEIVE DC LOOP (fig. FO-6)

The receive dc loop is a dc series circuit containing loop current switch A5A2Q1 in series with receive steering quad A5A2CR1, CR2, CR3, CR4, a current supply, and tty receive equipment (attached to the modem). The receive dc loop also contains relay A5A2K1 for switching between receive dc loops. As explained in the preceding paragraph, a mark tone input to the MD-522A/GRC results in loop current switch A5A2Q1 being biased into conduction. Current supplied by either the modem or an external supply flows through the receive steering quad, conducting loop current switch A5A2Q1, and to attached tty receive equipment. The source of dc and the supplied loop depends upon the setting of SEND/REC switch S5, DUPLEX/ONE WAY switch S1, and loop battery module internal-external switch A5S1.

Receive Dc Loop in Duplex Operation. When ONE WAY/DUPLEX switch S1 is set at DUPLEX, receive-send relay A5A2K1 is energized, automatically switching dc loop No. 1 to current supply 1, which is used for the transmit (send) half of duplex operation. In duplex, duplex/one-way relay A5A2K2 is unenergized, connecting the positive output of current supply 2 to receive steering quad A5A2CR1, CR2, CR3, CR4. The positive side of current supply 2 is connected to loop current switch A5A2Q1 through the receive steering quad. Because the rest of the dc loop is a closed series circuit when loop current switch A5A2Q1 is biased on, loop current supplied by current supply 2 flows through switch A5A2Q1, the other duplex contacts of relay A5A2K2, and out pin A of jack J7 to dc loop No. 2, the loop used for duplex receive, or pony operation in one way. The current pulses key the tty equipment in series with dc loop No. 2. Return is applied through pin C of J7 to the negative side of current supply 2.

Receive Dc Loop in One-Way Operation. With ONE WAY/DUPLEX switch S1 set at ONE WAY, relay A5A2K2 is energized, switching current supply 2 out of the receive dc loop. With RCV/SEND switch S5 at RCV, relay A5A2K1 is deenergized. The positive side of current supply 1 is applied to loop current switch A5A2Q1 through the RCV contacts of A5A2K1 and receive steering quad A5A2CR1, CR2, CR3, CR4. When the loop current switch is biased on, loop current from current supply 1 flows through the switch, the other pair of A5A2K1 RCV contacts, and out pin A of jack J6 to dc loop no. 1, the loop used for one-way receive and duplex send. The current pulses controlled by loop current switch A5A2Q1 key the tty equipment in series with dc loop No. 1. Return is applied through pin C of J6 to the negative side of current supply 1.

External Operation. When internal-external switch A5S1 is set at external for a given loop, the associated diode bridge rectifier and current regulator are switched off and out of the dc loop. The resulting loop current path is exactly the same as for internal operation, except that the supply is external and unregulated. The steering quad permits connection of the external supply without regard for the polarity of the external supply. If the external supply is connected backwards, the loop current will be routed by the steering quad so that the direction of the current flow through loop current switch A5A2Q1 is the same, regardless of the polarity of the external supply.

1-34. DIVERSITY SWITCHING (fig. FO-5)

In 85-Hz diversity, diversity switching circuitry samples tty channel 1 and tty channel 2, and squelches the weaker channel, if the difference in level is greater than 3 decibels (db). Diversity switching circuitry consists of diversity control adjusters A4A2R5 and A4A2R13; detectors A4A2CR3, CR4 and A4A2CR7, CR8; diversity channel control differentiating amplifier A4A2Z2; threshold diodes A4A2VR4 and A4A2VR5; channel 1 switch A4A2Q3; and channel 2 switch A4A2Q4. In 85-Hz diversity, the input to the modem consists of 425-Hz nsk and 2,805-Hz nsk. The 2,805-Hz nsk is applied unchanged to tty channel 2, and the 425-Hz nsk applied to tty channel 1 is mixed up to 2,805-Hz nsk. The channel 1 (2,805-Hz nsk) is sampled through tty channel 1 diversity control adjust A4A2R5, and detected by detector A4A2CR3, CR4. The dc output of detector A4A2CR3, CR4 is applied to diversity channel control differentiating amplifier A4A2Z2. Amplifier A4A2Z2 compares the channel 1 sample with the channel 2 sample. Assume the level of channel 1 (2,805-Hz nsk) is higher than that of channel 2. Amplifier A4A2Z2 will switch to a high state for the channel 1 sample, and to a low state for channel 2. Thus, channel 2 threshold zener diode A4A2VR5 is biased into nonconduction and threshold zener A4A2VR4 conducts. When A4A2VR4 conducts, channel 2 switch A4A2Q4 is biased in a low state. With A4A2Q4 in a low state, weaker channel 2 is grounded, squelching the channel 2 output. If channel 1 were the weaker channel, the switching process would have been reversed and channel 1 would have been grounded through A4A2Q3. Threshold zener diodes A4A2VR4 and A4A2VR5 establish a 3-db differential. When tty channel 2 is grounded, a voltage sample taken from limiter amplifier A4A2Q5 energizes relay A2A1K1 in the scope module, switching the scope input to channel 1 frequency discriminator A4A1T1, Q7, Q8. In the deenergized position, the scope output of fsk/nsk frequency discriminator A4A2T2, Q9, Q10 is sampled.

1-35. TTY SQUELCH (MARK HOLD) SWITCHING (fig. FO-5)

The tty squelch switching circuitry consists of tty squelch adjust A4A2R1; tty channel 1 diversity control adjust A4A2R5; tty channel 2 diversity control adjust A4A2R13; detectors A4A2CR1, CR2, A4A2CR3, CR4, and A4A2CR7, CR8; auctioneer circuit A4A2CR5, CR6; tty squelch differentiating amplifier A4A2Z1; threshold zener A4A2VR1; tty squelch switch A4A2Q1; AUTO MARK HOLD switch S6; and dc-coupled bistable multivibrator A4A1Q5, Q6. Unfiltered signal plus noise is applied to tty squelch adjust A4A2R1. Tty squelch detector A4A2CR1, CR2 rectifies the signal plus noise, and applies a dc voltage to tty squelch differentiating amplifier A4A2Z1 which is proportional to the signal-plus-noise level. Meanwhile, at diversity squelching (para 1-34), a dc voltage that is proportional to signal levels of filtered tty tones in tty channels 1 and 2 has been derived through their respective diversity control adjusters and detectors. In all modes but 85-Hz diversity, signal is present in only one tty channel. In 85-Hz diversity, signal is present in both channels. In either case, auctioneer circuit A4A2CR5, CR6 selects the higher output of the diversity control detectors for tty channel 1 or 2 and applies it as the second input to tty squelch differentiating amplifier A4A2Z1. Amplifier A4A2Z1 compares the level of the dc derived from tty channel 1 or 2 signal (with wideband noise filtered out) to the level of dc derived from unfiltered signal plus wideband noise. When the signal-to-noise ratio of signals applied to the modem falls below a preset level (as measured in A4A2Z1), threshold zener A4A2VR1 conducts, biasing tty squelch switch A4A2Q1 in a low state. Tty squelch switch A4A2Q1 is connected direct to input D of dc-coupled bistable multivibrator A4A1Q5, Q6; D is effectively grounded. If input D is lower than input C, a normal mark (that is, a positive voltage) will appear at ac-coupled bistable multivibrator A4A2Q7, Q8 output G (para 1-29). Tty squelch switch A4A2Q1 can be disabled (locked in a high state) by setting AUTO MARK HOLD switch S6 at OFF. Thus, with AUTO MARK HOLD switch at ON, and when the tty signal-to-noise ratio falls below a preset level, tty signals will be squelched, locking receive tty equipment in a mark condition. This action prevents copying unintelligible information, or the excitation of tty equipment by random noise when transmission from the sending station pauses momentarily.

1-36. VOICE AND TTY MONITOR SIGNAL PATH (fig. FO-5)

The receive voice and tty monitor signal path consists of a main signal path and audio squelch switching.

Main Signal Path. The signal path consists of voice channel isolation amplifier A7Q2, receive voice filter FL5, AUDIO GAIN control R1, driver A1A1Q1, and push-pull amplifier A1A1Q2, Q3, T1. The same input which is applied to tty channel isolation amplifier A7Q1 (para 1-26) is simultaneously applied to voice channel isolation amplifier A7Q2. In 85 Hz plus voice, 2,805-Hz nsk tty tones are filtered out by receive voice filter FL5; in all other modes, the filter is bypassed, and tty tones or voice signals are applied to driver A1A1Q1 through AUDIO GAIN control R1. Driver A1A1Q1 amplifies the input signal and drives push-pull amplifier A1A1Q2, Q3, T1. Amplifier A1A1Q2, Q3, T1 puts out a 2-watt audio signal for loudspeaker, and a 10-milliwatt (mw) signal for headphones. Thus, voice transmissions can be monitored in voice and 85 Hz plus voice modes; in all other modes, tty tones can be monitored.

Audio Squelch Switching. SQUELCH SENS control R9 samples the signals applied to AUDIO GAIN control R1, and applies the sample to detector A1A1Q2, which puts out a dc voltage proportional to the strength of the sample signal. The dc voltage is applied to phase reversal amplifier A1A1Q3. Amplifier A1A1Q3 produces an amplified dc voltage inversely proportional to its input. When the level of the input sample falls to a predetermined level, the output of amplifier A1A1Q3 rises to a level that causes threshold zener A1A1VR1 to conduct, biasing switch A1A1Q4 into conduction. With switch A1A1Q4 in a low state, the input to driver A1A1Q1 is grounded, squelching the output of the voice any tty monitor signal path.

1-37. DETAILED BLOCK DIAGRAM ANALYSIS OF SCOPE MODULE (fig. FO-7)

The scope module consists of a scope amplifier section, a scope channel control, a scope Intensity squelch, and a scope power supply.

Scope Amplifier and Channel Switching. Scope amplifier and channel switching consists of horizontal amplifier A2A1Q1, T1, vertical amplifier A2A1Q2, T2, threshold zener A2A1VR1, channel switch A2A1Q5, and relay A2A1K1. Tty channel 1 frequency discriminator A4A1Q9, Q10 is tuned to 2,805 Hz. Because 2,805-Hz fsk (or nsk) is applied to the frequency discriminator, the mark and space pulses are below and above resonance, respectively, producing phase differences that result in a differential voltage output. The differential output depends on the input frequency. This differential voltage is applied to scope module horizontal channel 1 and vertical channel 1. Similarly, a differential voltage produced by nsk frequency discriminator A4A2T1, Q7, Q8 is applied to scope module horizontal and vertical channels 2. When tty channel 2 is squelched because of the operating mode, or in 85-Hz diversity because of a stronger signal on tty channel 1, limiter amplifier A4A2Q5 produces a strong positive output to the scope channel control. When a strong positive voltage is applied, threshold zener A2A1VR1 conducts, switching channel switch A2A1Q5 into a low state. Current flows through A2A1Q5, energizing relay A2A1K1. When energized, relay A2A1K1 selects scope channel 1. If receive tty channel 2 is being used, channel switch A2A1Q5 is biased off, and unenergized relay A2A1K1 applies scope channel 2 to the horizontal and vertical amplifiers. The horizontal and vertical amplifiers raise the level of the input signal and apply it to the horizontal and vertical deflection plates, respectively, of the scope CRT.

Scope Intensity Squelch. The scope intensity squelch circuitry consists of SQUELCH ADJ A2A1R25, amplifier A2A1Q4, amplifier A2A1Q3, transformer A2A1T3, detector A2A2CR4, CR5, squelch switch A2A2Q1, and SCOPE INTENSITY control R3. The emitter-follower output of vertical amplifier A2A1Q2 is sampled through SQUELCH ADJ A2A1R25 and is applied to amplifier A2A1Q4, which raises the signal to the required level. Amplifier A2A1Q3 is coupled through high-voltage isolation transformer A2A1T3, and provides an output directly proportional to the output of vertical amplifier A2A1Q2, T2. Transformer A2A1T3 provides a balanced input to detector A2A2CR4, CR5, which provides the dc input to squelch switch A2A2Q1. Squelch switch A2A2Q1 parallels the wiper and negative most side of SCOPE INTENSITY control R3. When the level in the vertical channel falls below a preset value, squelch switch A2A2Q1 conducts less, applying a higher negative potential to the scope intensity grid, and squelching the scope pattern. Similarly, when the level in the vertical channel rises above a preset value, the squelch switch conducts more, restoring the scope pattern to the screen.

Scope Power Supply. The scope power supply consists of dc-to-ac Inverter A2Q1, Q2, T1, which converts +22 volts dc into 1,000 volts peak to peak for rectification by voltage doubler rectifier A2A2CR1, CR2, which supplies 1,000 volts dc to the scope voltage divider.

Section VI. STAGE ANALYSIS, TRANSMIT SIGNAL PATHS

1-38. INTRODUCTION

This section presents detailed stage analysis of the modem transmit circuits, including transmitter module A3 and loop battery module A5. Wherever possible, the discussion of the circuits is limited to a module basis. Figure FO-8 is the overall schematic diagram of modem. Refer to it as necessary during the following discussion for the details of signal paths between modules and for switch connections.

1-39. LOOP BATTERY MODULE A5 (fig. FO-9)

The loop battery module analysis is given in paragraphs 1-40, 1-41, and 1-42 and consists of two identical dc-to-ac inverter and current regulator circuits, a receive sensing circuit, a send sensing circuit, and associated switching circuits.

LOOP BATTERY MODULE DC TO AC INVERTER

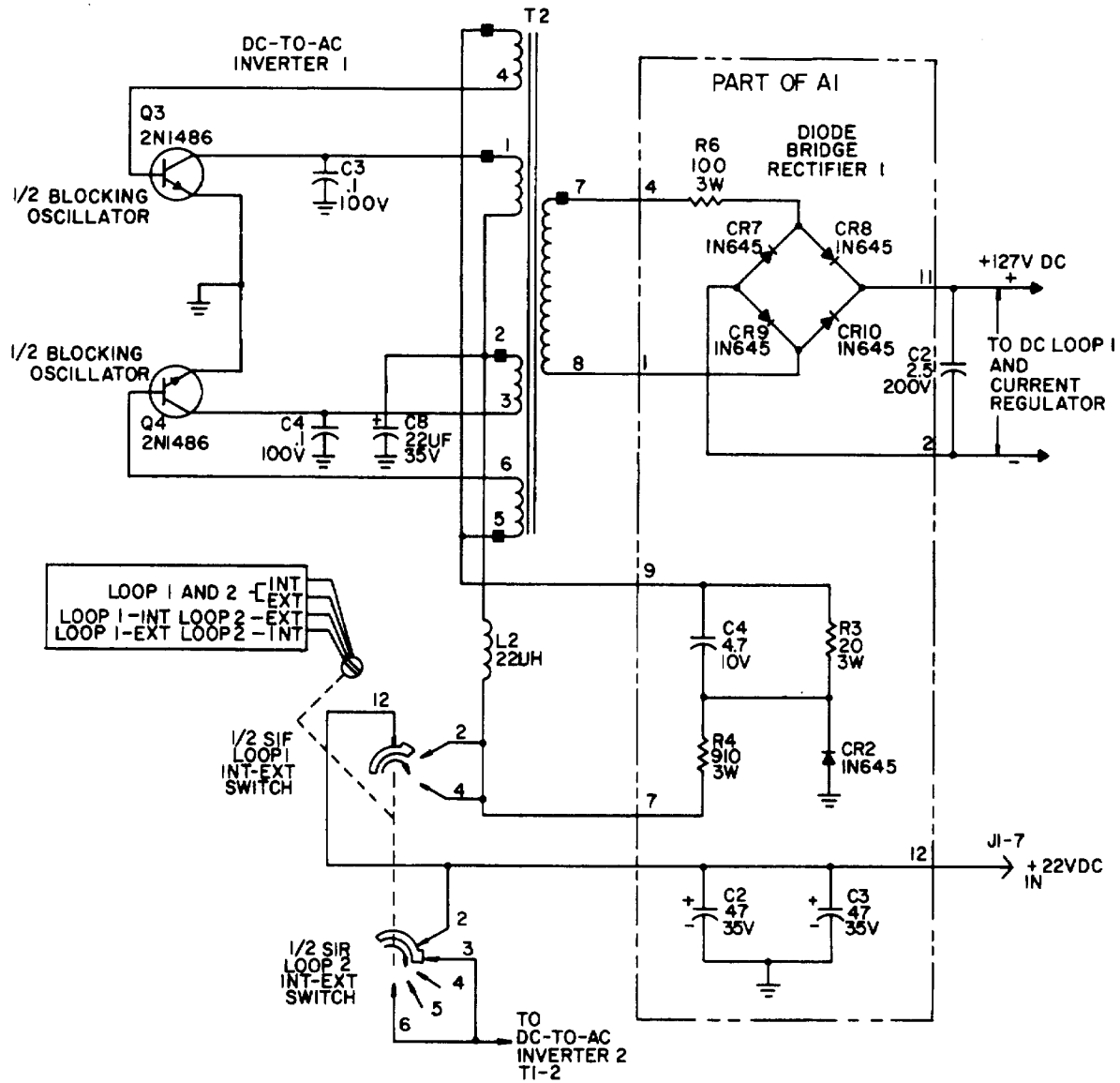

NOTES:

1. PREFIX PARTIAL REFERENCE DESIGNATORS WITH A5
2. SI IS SHOWN IN THE CCW POSITION
3. RESISTORS ARE IN OHMS, CAPACITORS IN MICROFARADS
4. DC-TO-AC INVERTER 2 IS IDENTICAL, EXCEPT FOR REFERENCE -DESIGNATORS
5. SI-F IS SET AT LOOP 1-EXT LOOP 2-INT

1-40. DC-TO-AC INVERTER AND CURRENT REGULATOR

The dc-to-ac inverter and current regulator circuits convert +22 volts dc from the modem power supply into +127 volts dc, regulated 20 or 60 mA current source for dc loops 1 and 2. One dc-to-ac inverter and current regulator are associated with each dc loop. As operation of the circuits are identical, only the circuits for dc loop No. 1 will be discussed.

Dc-to-ac inverter 1 consists of blocking oscillator A5Q3, A5Q4, and A5T2; starting resistors A5A1R4 and A5A1R3; feedback diode A5A1CR2; capacitor A5A1C4; transient suppressor circuitry A5C3, A5C4, A5C8, A5L2; and bridge rectifiers A5A1CR7 through A5A1CR10. A preregulated +22 volts dc is applied to connector A5J1-7. Capacitors A5A1C2 and C3 filter out noise superimposed on the voltage. The +22 volts dc is then applied to dc-to-ac inverter 1 through contacts 12 and 2 of internal-external switch A5S1. Dc-to-ac inverter 1 transistors A5Q3 and A5Q4 alternately switch the +22 volt dc input voltage from one half of the A5T2 primary to the other. Initially, one transistor (A5Q3 for example) is biased on through starting resistors A5A1R4 and A5A1R3. As transistor A5Q3 starts to conduct, it is driven into full conduction by the positive feedback from winding 4-5 of transformer A5T2. (The feedback return is through A5A1CR2 and A5A1C4.) When the core of A5T2 saturates, the feedback to A5Q3 is reduced, and the transistor turns off. The changing flux, caused by A5Q3 turning off, generates a negative feedback in A5T2 winding 4-5, driving A5Q3 even further into nonconduction. The same collapsing field generates a voltage in winding 5-6 of the proper polarity to turn transistor A5Q4 on. This way, an alternating square wave is impressed on the primary of transformer A5T2. Frequency of operation is determined by the magnetic characteristics of the saturable core of A5T2, and capacitor A5A1C4 increases the switching time of the transistors. Capacitors A5C3 and A5C4 form a capacitor input filter with A5C8 and choke A5L2 to slow down risetime, suppressing switching transients.

The square wave output signal of transformer A5T2 is rectified by diode bridge rectifier A5A1CR7, through CR10, filtered by capacitor A5C2 and applied to current regulator 1 and dc loop No. 1. The output voltage is approximately 127 volts dc. Current regulator 1 consists of reference zener diodes A5A2VR5 and VR6, voltage divider A5R2, A5A2R 14, R 15, R 16, comparator A5A2Q5, sampler resistors A5A1 R17 and R18, and series regulator A5Q6. Zener diodes A5A2VR5 and VR6 and diodes A5A2CR17 and CR 18 provide a constant 13.7 volts dc for reference voltage divider A5A2R 14, R 15, R16. Diodes A5A2CR17 and CR18 compensate for changes in zener voltage caused by temperature variations. Current output (20 or 60 mA) is selected by front panel DC LOOP NO. 1 switch S7. Assume the switch is set at 20 MA. When current through sampler resistor A5A2R17 drops below 20 mA, the emitter voltage of series regulator A5Q6 also drops, and its base voltage follows. Because the base of A5Q6 is common with the emitter of comparator A5A2Q5, and the base of A5A2Q5 is held at a constant reference voltage by the reference zener diodes, comparator A5A2Q5 is biased into greater conduction. This biases series regulator A5Q6 into greater conduction, increasing the current flow through the transistor and sampler resistor A5A2R 17. The action continues until 20 mA loop current is restored. Similarly, if the loop current tends to exceed the 20 mA loop current, series regulator A5Q6 will be biased to conduct less. When DC LOOP NO. 1 switch S7 is set at 60 MA, resistor A5A2R18 parallels resistor A5A2R17, changing the overall resistance of the sampler network so that the current regulator adjusts to 60 mA instead of 20 mA. Potentiometer A5A2R15 (LOOP 1 ADJ) allows the current output of the regulator to be adjusted +10, or -10 percent. Capacitor A5A2C15 suppresses zener noise and provides the capacitance for capacitor multiplier consisting of A5A2Q5 and A5Q6, which smooths ripples and transients. Zener diode A5A2VR7 provides over-voltage protection for transistors A5A2Q5 and A5Q6. Voltage peaks greater than 130 volts will be bypassed around the transistors through A5A2VR7. The 127 volts dc, now dropped to 120 volts dc by A5VR6, is then passed through contacts of internal-external switch A5S1, supplying a regulated 20 or 60 mA to external dc loop No. 1.

LOOP BATTERY MODULE CURRENT REGULATOR

1/2 A5SI-R
LOOP 2
INT-EXT SWITCH

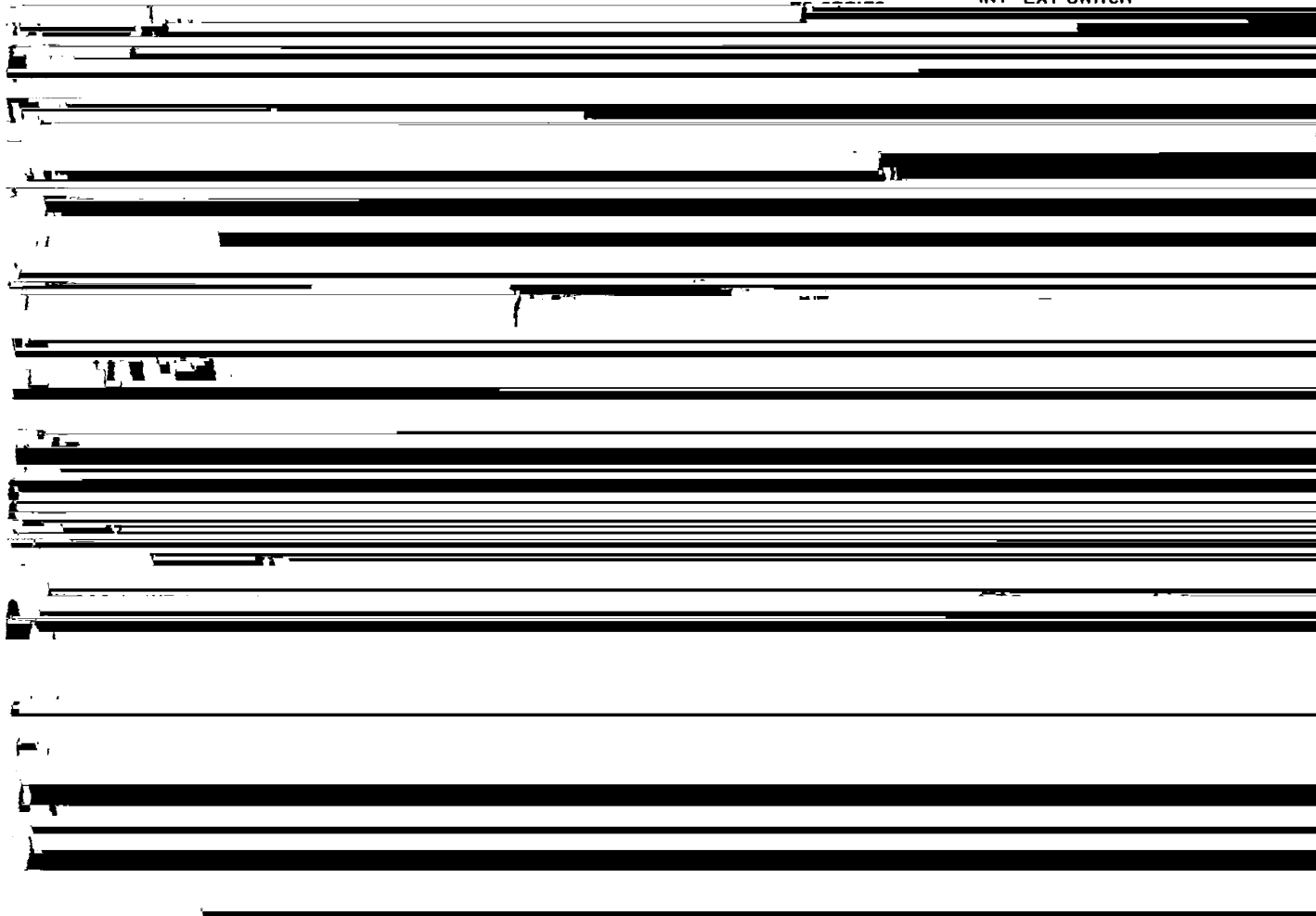

LOOP BATTERY MODULE RECEIVE SENSING

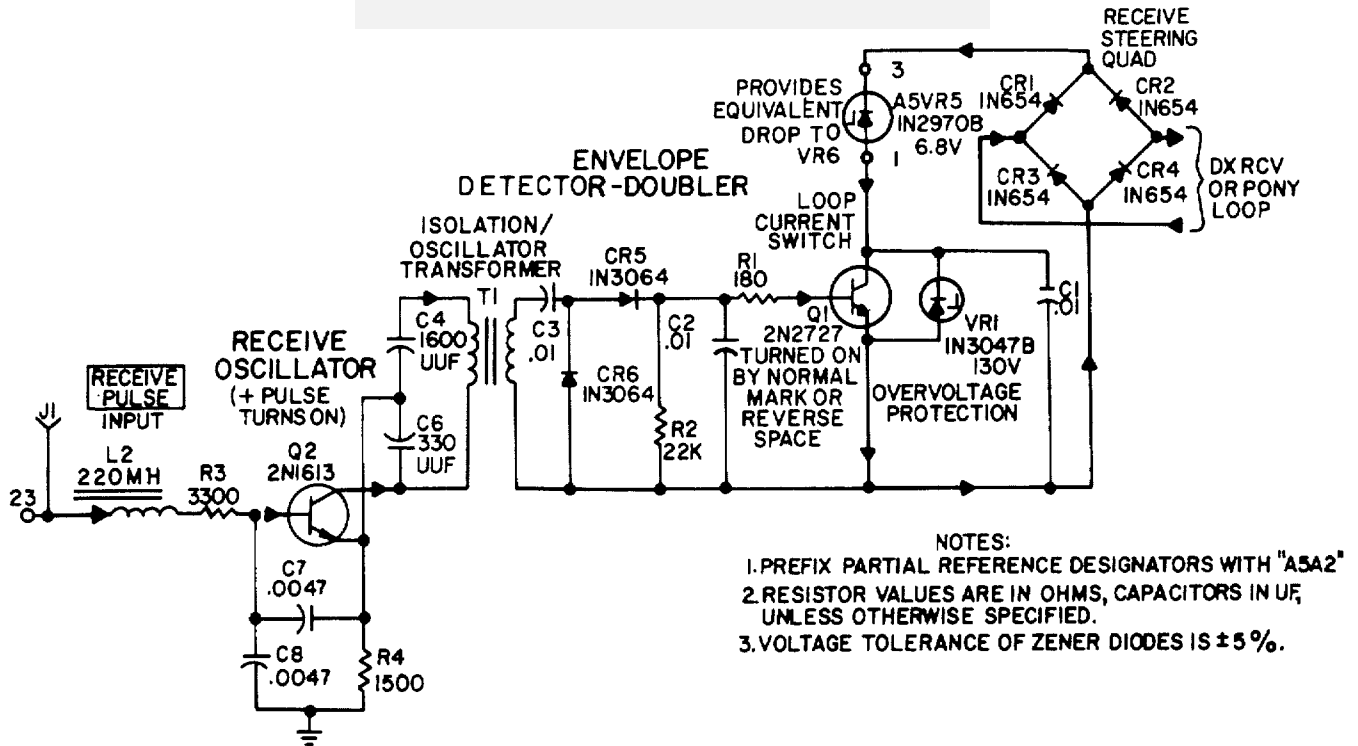

1-41. RECEIVE AND SEND SENSING CIRCUIT

Receive Sensing Circuit. The receive sensing circuit controls the flow of dc loop current. The current causes loop current to flow when a tty mark pulse is received and no current to flow when a space pulse is received. Loop current may be supplied either by the Internal dc-to-ac Inverter and current regulator (para 1-40) or by an external power supply. When a mark tty signal is received, circuits of receiver module A4 develop a positive pulse. No pulse is developed when a space tty signal is received. The positive pulse is applied through connector A5J1-1 and rf noise filter A5A2L2, A5A2R3, A5A2C8 to the base of receive oscillator transistor A5A2Q2. The receive oscillator turns on for the duration of the positive input pulse. The signal from the oscillator is applied by oscillator-isolation transformer A5A2T1 to an envelope detector-doubler consisting of A5A2C3, A5A2CR6, A5A2CR5, A5A2R2, and A5A2C2. The resulting dc output from the envelope detector-doubler is applied through resistor A5A2R1 to the base of loop current switch A5A2Q1. Thus, when a normal mark pulse is received, loop current flows through steering quad diode A5A2CR4, the emitter and collector of forward-biased switch A5A2Q1, zener diode A5VR5, and steering quad diode A5A2CR1 to operate tty machines connected to the dc loop. When a normal space is received, switch A5A2Q1 is reverse biased and no current flows through the dc loop zener diode A5VR5 duplicates the voltage drop of regulator zener diode A5VR6 in the send circuit. This permits use of either current regulator 1 or 2 with either the send or receive circuit, as required when the mode of operation is switched from duplex to one way receive. Steering quad diodes A5A2CR1 through A5A2CR4 allow an external power supply to be used for loop current without regard for polarity. In the above discussion, if an external supply had been used and had been connected backwards, loop current would have flowed through diodes A5A2CR3 and A5A2CR2 (instead of A5A2CR4 and A5A2CR1, respectively). However, current flow through switch A5A2Q1 would not be affected.

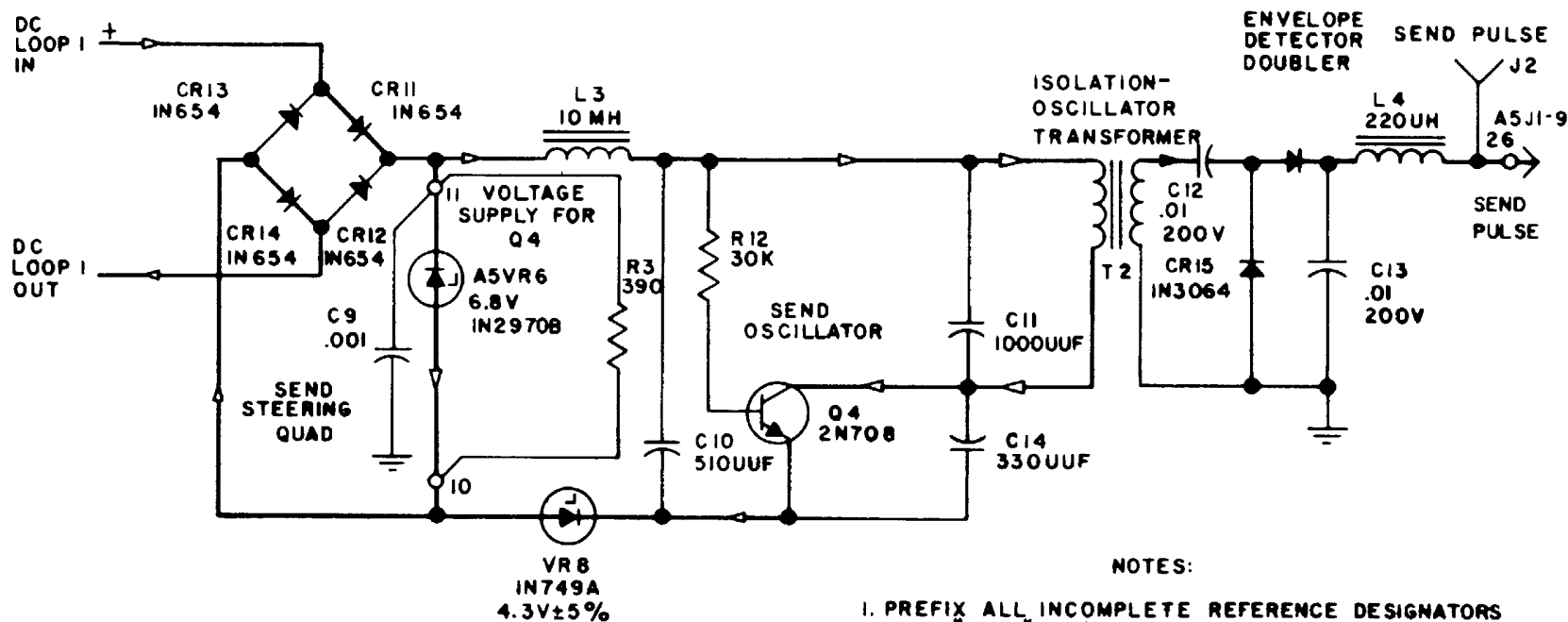

LOOP BATTERY MODULE SEND SENSING

Send Sensing Circuit. The send sensing circuit develops a positive dc output pulse whenever dc loop current flows (mark signal) and no output pulse when no current flows (space signal). Switching circuitry (para 1-42) connects the send steering quad into the send dc loop. When the tty machine in the dc loop closes the loop, current flows through steering quad diode A5A2CR14, send oscillator voltage supply zener diode A5VR6, and steering quad diode A5A2CR11. Thus, when loop current flows, +6.8 volts dc appears across zener diode A5VR6. This dc level is filtered through choke A5A2L3 and is simultaneously applied to the base and collector of send oscillator A5A2Q4, gating the oscillator on. The frequency of the oscillator is determined by the resonant circuit composed of capacitor A5A2C11 and the inductance of the primary of transformer A5A2T2. Transformer A5A2T2 isolates the following circuitry from the dc loop and associated tty machines, preventing problems associated with grounding. The send oscillator signal is rectified by an envelope detector-doubler consisting of A5A2C12, A5A2CR15, A5A2CR16, and A5A2C13. The resulting dc pulse (send pulse) is applied to transmitter module A3 through pin 9 of connector A5J1. When the send dc loop is open (space signal), no voltage drop occurs across zener diode A5A2VR6. Consequently, send oscillator A5A2Q4 is cut off and no output pulse appears. Steering quad diodes A5A2CR11 through A5A2CR14 allow an external power supply to be used without regard to polarity (para 1-40).

1-42. SWITCHING CIRCUITS
(fig. FO-9)

Internal-External Switch. Combinations of the dc-to-ac inverter and current regulator, receive sensing and send sensing circuits (para 1-41) will be used for each mode of operation of the modem. Internal-external switch A5S1 selects an internal or external power source for each dc loop, regardless of mode of operation. The internal current supply actually used does depend on the mode of operation. Power sources corresponding to each switch setting of A5S1 for duplex mode are listed in the following chart.

INT-EXT SWITCH SETTING	POWER SOURCE	
	DC LOOP 1	DC LOOP 2
Loop 1-Ext Loop 2-Int	External source	Dc-to-ac inv 2, current reg 2
Loop 1-Int Loop 2-Ext	Dc-to-ac inv 1, current reg 1	External source
Loop 1 and 2-Ext	External source	External source
Loop 1 and 2-Int	Dc-to-ac inv 1, current reg 1	Dc-to-ac inv 2, current reg 2

Loop Current Paths. Relays A5A2K1 and A5A2K2 are controlled by grounds supplied by front panel switches RCV/SEND S5 and ONE WAY/DUPLEX S1, respectively. These relays switch the loop currents to the send and receive sensing circuits, depending on the settings of the front panel switches. The following chart shows the loop current paths for each setting of the ONE WAY/ DUPLEX and RCV/SEND switches (module A5 circuit interconnection for various modem modes).

LOOP CURRENT PATHS

ONE WAY/DUPLEX switch setting	RCV/SEND switch setting	Current Source	Through		To sensing circuit	To external loop No.	Through	
			Relay	Contacts			Relay	Contacts
DUPLEX	SEND	Current supply 1	A5A2K1	B1, B2	Send	1	A5A2K1	A1, A2
ONE WAY		Current supply 2	A5A2K2	A3, A2	Receive	2	A5A2K2	B2, B3
		Current supply 1	A5A2K1	B1, B2	Send	1	A5A2K2	A1, A2
		Current supply 2	A5A2K2	A2, A1	For ext use such as pony circuit	2	A5A2K2	B1, B2
ONE WAY	RCV	Current supply 1	A5A2K1	B2, B3	Receive	1	A5A2K1	A3, A2
		Current supply 2	A5A2K2	A2, A1	For ext use such as pony circuit	2	A5A2K2	B1, B6

Current may be supplied either from the internal dc-to-ac inverter and current regulator circuits, or from an external power supply, depending on the setting of internal-external switch A5S1.

1-43. TRANSMITTER MODULE A3
(fig. FO-10)

General. Transmitter module A3 contains tty signal (mark and space tones) generation circuitry, transmit voice circuits, and output amplifying circuits.

Tty Signal Generation. Mark and space tone signals are derived from oscillators with outputs that are switched by associated switching circuitry and divided to the proper frequency by divider circuits. Depending on the mode of operation, the outputs are mixed in various combinations to develop the proper output frequency.

- **Mark oscillator.** Oscillator A3A1Q19, Q20 provides the fundamental frequency used to generate a mark tone. The circuit consists of a modified astable multivibrator that has a crystal in the feedback path to sustain oscillations at the desired frequency. Frequency of operation is determined by crystal A3A1Y1, operating in the series-resonant mode. The feedback path is through coupling resistor A3A1R45, crystal A3A1Y1, and series capacitor A3A1C28 to the base of transistor A3A1Q20. Trimmer capacitor A3A1C27 allows slight pulling of the oscillator frequency to compensate for circuit parameters. Resistor A3A1R46 and capacitor A3A1C26 form a resistance-capacitance (rc) network, which assures that the crystal starts in its fundamental series-resonant mode. The resulting 221.0-kHz signal that is developed across collector load resistor A3A1R44 is applied to shaper amplifier A3A1Q4 through isolation diode A3A1CR3.

MARK (221.0 kHz) OSCILLATOR

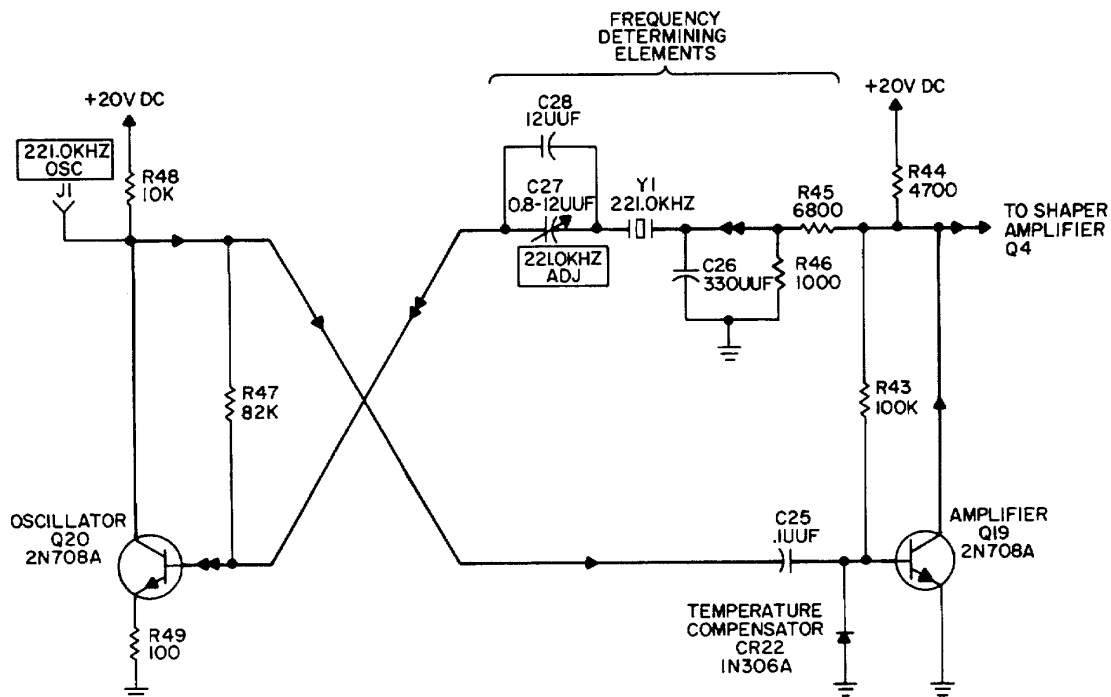

NOTES:

1. PREFIX PARTIAL REFERENCE DESIGNATORS WITH A3A1
2. RESISTOR VALUES ARE IN OHMS.
3. MAIN SIGNAL FLOW IS INDICATED BY HEAVY LINE AND ARROWHEAD® ; FEEDBACK BY DOUBLE ARROWHEAD↔
4. 227.8KHZ(SPACE)OSCILLATOR A3A1,Q21,Q22 IS IDENTICAL TO THIS SCHEMATIC EXCEPT FOR FREQUENCY DETERMINING ELEMENTS AND REFERENCE DESIGNATORS

- **Space oscillator.** Oscillator A3A1Q21, Q22 provides the fundamental frequency used to generate the space tone. The circuit is identical with the 221.0-kHz oscillator described in (1) above, except for the frequency-determining elements and reference designators. The 227.8-kHz output of the oscillator is applied to shaper amplifier A3A1Q4 through isolation diode A3A1CR4.

1-44. MARK AND SPACE OSCILLATOR OUTPUT SWITCHING (fig. FO-10)

The oscillator output switching circuits consists of phase reverse switch A3A1Q1, 221.0-kHz switch A3A1Q2, 227.8-kHz switch A3A1Q3, isolation diodes A3A1CR3 and A3A1CR4, and shaper amplifier A3A1Q4. The output of either the mark or space oscillator will be applied to shaper amplifier A3A1Q4, depending on whether a mark or space tone is to be generated.

A positive dc pulse is generated by the send circuit of loop battery module A5 (para 1-41) each time a mark tone is to be transmitted. This positive pulse is applied through connector A3J3 pin 14 and rf noise filter A3A1C33, L2 to contact 2 of transmit REV/NORM switch A3A1S1. With the switch set at NORM, the pulse is connected to the base of phase reverse switch A3A1Q1, causing the transistor to conduct. The resulting low collector voltage of A3A1Q1 biases 221.0-kHz switch A3A1Q2 to the nonconducting state. With switch A3A1Q2 off, no voltage drop occurs across collector load resistor A3A1R4. This allows the +20 volt dc supply voltage to be applied through A3A1R4 to forward bias isolation diode A3A1CR3, turning on 227.8-kHz switch A3A1Q3. The 221.0-kHz mark oscillator frequency (coupled to diode A3A1CR3) is coupled through the forward biased diode to shaper amplifier A3A1Q4. The 227.8-kHz space oscillator frequency applied to isolating diode A3A1CR4 is blocked, because the diode is reversed biased by the low collector voltage of conducting switch A3A1Q3.

When a space tone is to be generated, no pulse is present at the input to phase reverse switch A3A1Q1. The circuits are biased so that with no input, transistor A3A1Q1 is nonconducting and transistor A3A1Q2 is conducting, holding A3A1Q3 off. Consequently, the 221.0-kHz mark oscillator signal is blocked and the 227.8-kHz space oscillator signal is fed through biased diode A3A1CR4 to shaper amplifier A3A1Q4. Shaper amplifier A3A1Q4 amplifies the oscillator input signal and shapes it to the proper waveform to trigger the bistable multivibrators of the divide-by-8 circuit (para 1-45).

When transmit REV/NORM switch A3A1S1 is set at REV, phase reverse switch A3A1Q1 is bypassed, and the base of 221.0-kHz switch A3A1Q2 is grounded through resistor A3A1R2 and contacts 4 and 5 of the switch. Thus, switch A3A1Q2 is held nonconducting and a mark frequency (221.0 kHz) is fed to shaper amplifier A3A1Q4 until a send pulse is received.

1-45. MARK AND SPACE OSCILLATOR OUTPUT DIVIDER CIRCUITS (fig. FO-10)

The mark and space oscillator output divider circuits consist of a divide-by-8 circuit and a divide-by-10 circuit. The mark or space oscillator output is divided by 8 for the fsk (850-Hz) modes and by 10 for the nsk (85-Hz) modes.

Divide-by-8 is accomplished by a circuit composed of three series-connected divide-by-2 bistable multivibrators A3A1Q5, Q6; A3A1Q7, Q8; and A3A1Q9, Q10. The circuit is used during all modes of operation. A 221.0-kHz mark or 227.8-kHz space oscillator signal is applied to multivibrator A3A1Q5, Q6 from shaper amplifier A3A1Q4. The divide-by-8 chain of multivibrators divides the signal, and the resulting 27,625 or 28,475 Hz ($28,050 \pm 425$ Hz) signal from multivibrator A3A1Q9, Q10 is fed to both the divide-by-10 circuit and, through coupling resistor A3A1 R24, to the sine wave pass filter (para 1-30).

DIVIDE-BY-10 WAVEFORMS, TRANSMITTER MODULE A3

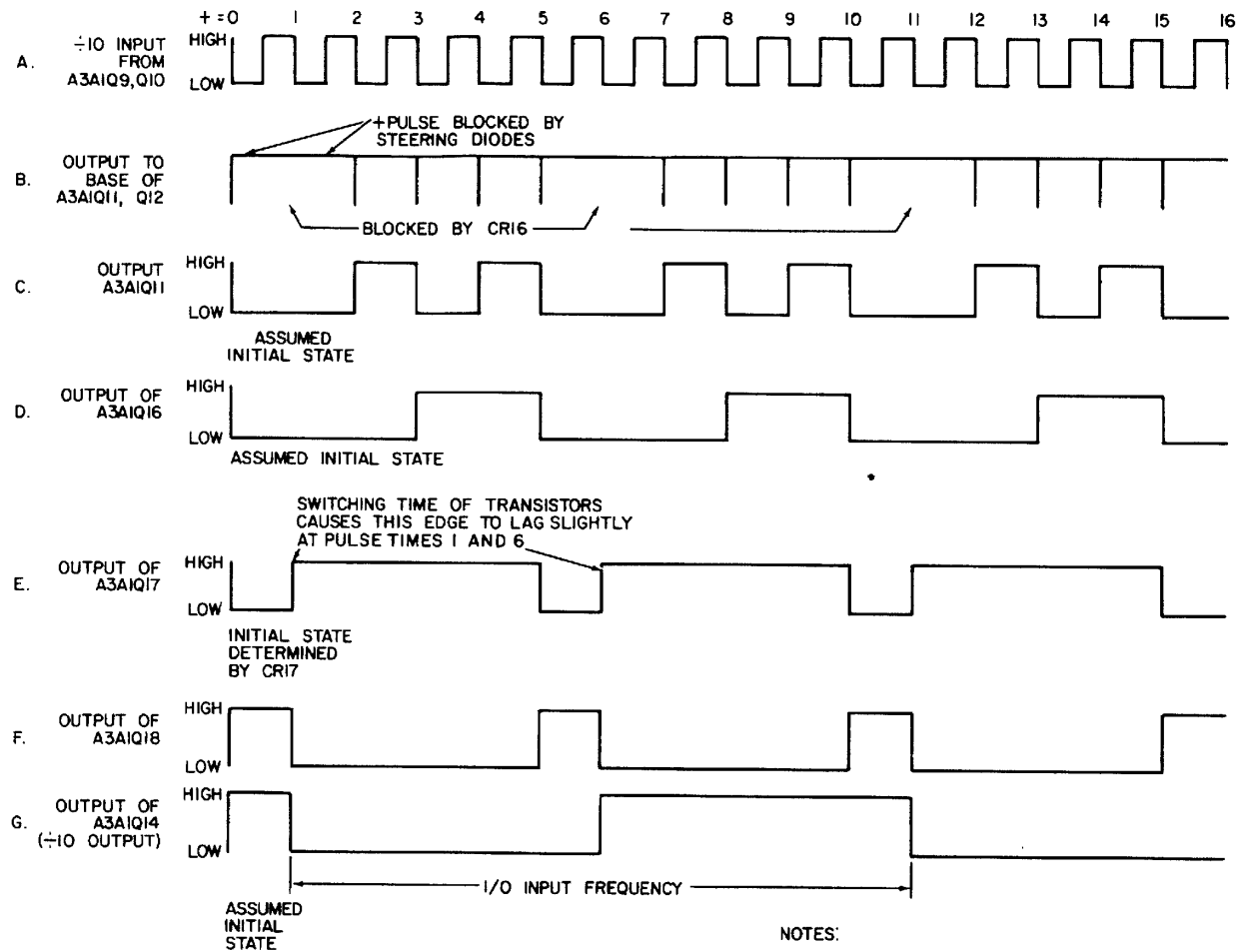

The divide-by-10 circuit is used only during the 85-Hz, 85-Hz diversity, and 85-Hz plus voice modes of operation of the modem. During the 850-Hz and voice modes of operation, no -20 volt dc operating voltage is supplied to the circuit from front panel MODE SELECTOR switch S4F. The circuit consists of three bistable multivibrators and a gate arranged in a divide-by-5 configuration followed by a divide-by-2 multivibrator. The preceding figure shows the waveform produced. The gate is formed by diodes A3A1CR16, CR17 and resistor A3A1 R42. As long as diode A3A1CR17 is reverse biased, the trailing edge of the square wave output pulses from the divide-by-8 circuit will pass through diode A3A1CR16, be differentiated by A3A1C16, R29 or A3A1C17, R34 and trigger bistable multivibrator A3A1Q11, Q12. Each pulse from the divide-by-8 circuit is also applied (after differentiation) to the base of transistor A3A1Q7 to set multivibrator A3A1Q17, Q18 so that the collector of A3A1Q17 is high and the collector of A3A1Q18 is low. After four input pulses multivibrator A3A1Q15, Q16 toggles to the state where the collector of A3A1Q16 is low. This causes multivibrator A3A1Q17, Q18 to change state, so that the collector of A3A1Q17 is low and the collector of A3A1Q18 is high. The low level at the collector of A3A1Q17 forward biases diode A3A1CR17, which in turn reverse biases diode A3A1CR16, preventing the fifth input pulse from being applied to multivibrator A3A1Q11, Q12. However, the fifth input pulse is applied to the base of A3A1Q18, resetting multivibrator A3A1Q17, Q18 so that the output of A3A1Q17 is high and the output of A3A1Q18 is low. This results in a negative-going (after differentiation) output pulse at the collector of A3A1Q18 for every five input pulses. The output of multivibrator A3A1Q17, Q18 is divided by 2 by multivibrator A3A1Q13, Q14, which results in a 2,762.5 or 2,847.5-Hz (2,805 + 42.5 Hz) signal that is applied through coupling resistor A3A1 R41 to the sine wave pass filter (para 1-50).

1-46. MIXER OSCILLATOR AND SWITCHING (fig. FO-10)

The mixer oscillator and switching circuit provides mixer injection frequencies used to establish the center frequencies of the 850-Hz mode and the lower band of frequencies used during 85-Hz diversity. The oscillator portion of the circuit consists of an a stable multivibrator A3A2Q3, Q4 with a crystal feedback. This oscillator is identical with the 221.0-kHz oscillator described in paragraph 1-43 except that two separate feedback paths through the frequency determining elements exist. Either path may be selected to determine the oscillator output frequency. The proper feedback path is selected by a ground from front panel MODE SELECTOR switch S4G to switching diode A3A2CR5 or A3A2CR6. Assume the MODE SELECTOR switch is set at 85 HZ DIVERSITY. Ground is applied to switching diode A3A2RC6 through cathode resistor A3A2R32, enabling the 23,800-Hz feedback path. No feedback occurs through the 26,050-Hz path because switching diode A3A2CR5 is not forward biased. Capacitor A3A2C10 suppresses undesirable modes of oscillations of the crystals.

Two outputs are obtained from the mixer oscillator circuit. The signal developed across collector load resistor A3A2R35 is always applied to divide-by-10 driver A3A2Q5 (para 1-47). An additional output is applied to the anode of divide-by-10 bypass switching diode A3A2CR10. With front panel MODE SELECTOR switch S4G at any setting except 850 HZ, diode A3A2CR10 is reverse biased. When the MODE SELECTOR switch is placed at 850 HZ, ground is applied through isolator A3A2CR12 and resistor A3A2R59 to forward bias switching diode A3A2CR10. The oscillator signal is then fed through coupling capacitor A3A2C11 and a filter, composed of A3A2R58, R57, and C17, to mixer A3A2T1 (para 1-48). Isolator A3A2CR12 prevents the 2,380-Hz signal from leaking through 2,000-Hz fsk pass filter FL2 in diversity mode.

**1-47. MIXER OSCILLATOR OUTPUT DIVIDER CIRCUITS
(fig. FO-10)**

During the 85-Hz diversity mode of operation only, the output of mixer oscillator A3A2Q3, Q4 is divided-by-10 before being applied to mixer transformer A3A2T1. The divide-by-10 circuits consists of divide-by-10 driver A3A2Q5 and divide-by-10 integrated circuit A3A2Z1.

A 23,800-Hz signal from mixer oscillator A3A2Q3, Q4 is applied to divide-by-10 driver A3A2Q5 when front panel MODE SELECTOR switch S4G is set at 85 HZ DIVERSITY. Driver A3A2Q5 shapes the oscillator signal to the proper waveform to trigger divide-by-10 integrated circuit A3A2Z1. The shaped signal is coupled through capacitor A3A2C7 and developed across resistor A3A2R49. When in the 85-Hz diversity mode of operation, ground for A3A2Z1 is provided through isolating diode A3A2CR11. In any mode except 85 Hz diversity, diode A3A2CR11 is ungrounded, biasing A3A2Z1 off.

Divide-by-10 integrated circuit A3A2Z1 is a monolithic decade counter integrated circuit connected in a divide-by-10 configuration. The circuit produces 1 output pulse for every 10 input pulses. The resulting 2,380-Hz square wave signal is applied through coupling capacitor A3A2C14 and a filter composed of A3A2R55, R56, and C12 to mixer A3A2T1. The signal is also coupled through resistor A3A2R61 and pin 9 of connector A3J1 for use as an injection frequency in receive audio module A1 (para 1-54).

Note that although the 26,050-Hz signal generated in the 850-Hz mode of operation is also shaped by driver A3A2Q5, no ground is applied through diode A3A2CR11 to divide-by-10 integrated circuit A3A2Z1. Consequently, the output of driver A3A2Q5 is not used.

1-48. SINE WAVE PASS FILTER, ISOLATION AMPLIFIER AND MIXER

The sine wave pass filter, isolation amplifier, and mixer circuit provide the output frequencies listed for each mode of operation of the modem in the chart below. The 2,805-Hz \pm 42.5 output is an amplified 2,805-Hz \pm 42.5 signal from the mark and space oscillator output divide-by-10 circuit A3A1Q11Q18; the 425-Hz \pm 42.5 signal is generated by subtractively mixing the 2,805-Hz \pm 42.5 signal with a 2,380-Hz signal from the mixer oscillator output divide-by-10 circuit A3A2Z1. Subtractively mixing a 26,050-Hz signal from mixer oscillator output divide-by-10 bypass switch A3A2CR 10 and a 28,050Hz \pm 425 signal from mark and space oscillator output divide-by-8 circuit A3A1Q5-Q10 develops the 2,000-Hz \pm 425 output.

MODE	OUTPUT FREQUENCY
850-Hz	2,000-Hz \pm 425
85-Hz	2,805-Hz \pm 42.5
85-Hz diversity	2,805-Hz \pm 42.5, 425-Hz \pm 42.5
85-Hz + voice	2,805-Hz \pm 42.5

TRANSMITTER MODULE MIXER CIRCUIT, SINE WAVE PASS FILTER AND ISOLATION AMPLIFIER

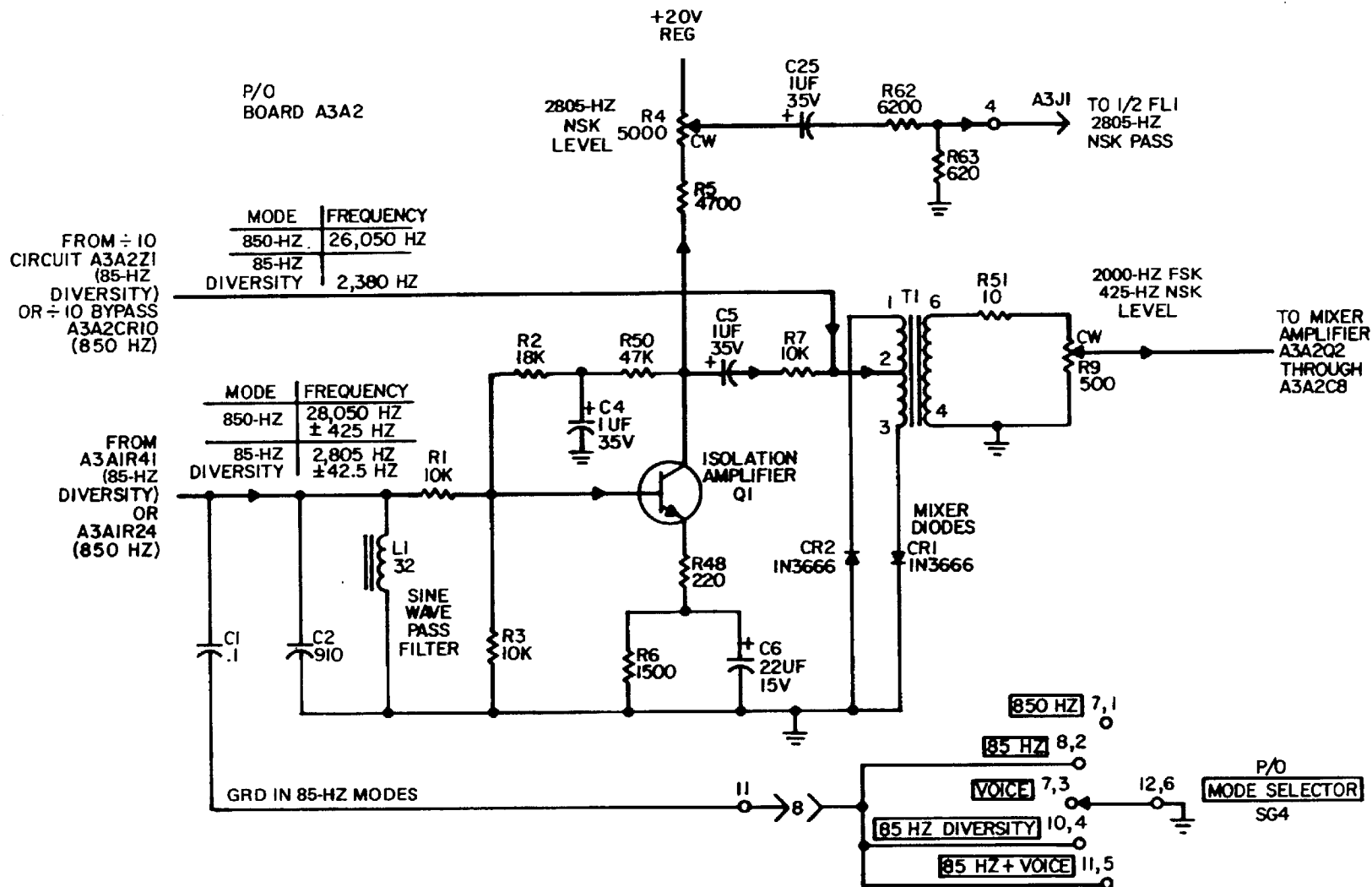

A 2,805-Hz \pm 42.5 (or 28,050-Hz \pm 425) signal is applied to sine wave pass filter A3A2C1, A3A2C2, and A3A2L1. The sine wave pass filter is a tuned circuit which converts the square wave input signal to a sine wave for amplification by isolation amplifier A3A2Q1. Capacitor A3A2C2 and inductor A3A2L1 are parallel-resonant at the input frequency of 28,050 Hz. In 850-Hz mode of operation, capacitor A3A2C1 is ungrounded and has no effect. During 85-Hz mode of operation, capacitor A3A2C1 is grounded through contacts of front panel MODE SELECTOR switch S4G. This changes the parallel-resonant frequency of the sine wave pass filter to 2,805 Hz. The resulting sine wave output of the filter is fed to the base of isolation amplifier A3A2Q1 through coupling resistor A3A2R1.

Isolation amplifier A3A2Q1 is a conventional common-emitter amplifier. Capacitor A3A2C6 bypasses only a portion of the emitter resistance of A3A2R48 and A3A2R6 in order to retain a high input impedance to the stage to prevent loading of the sine wave pass filter. The amplified output of the transistor is fed through potentiometer A3A2R4, coupling capacitor A3A2C25, voltage divider A3A2R62, R63, and pin 3 of connector A3J1 to 2,805-Hz nsk filter FL1.

The signal at the collector of isolation amplifier A3A2Q1 is also fed through coupling capacitor A3A2C5 and isolating resistor A3A2R7 to the primary of mixer transformer A3A2T1. There the signal is mixed with one from mixer oscillator output divide-by-10 circuit A3A2Z1 (85-Hz diversity mode) or from mixer oscillator output divide-by-10 bypass switch A3A2CR10 (850-Hz mode). Diodes A3A2CR1 and A3A2CR2 provide the nonlinear circuit elements necessary for mixing. The resulting difference frequency is coupled through mixer transformer A3A2T1 to potentiometer A3A2R9. A portion of the signal that appears across A3A2R9 is fed to mixer amplifier A3A2Q2 (para 1-49).

1-49. MIXER AMPLIFIER AND TRANSMIT FSK/NSK FILTER SWITCHING (fig. FO-10)

The mixer amplifier and fsk/nsk filter switching circuit amplify the 2,000-Hz \pm 425 or 425-Hz \pm 42.5 signal from mixer transformer A3A2T1 (para 1-48). The circuit also switches the amplified signal to either the fsk or nsk filter, depending on the mode of operation of the modem.

The 2,000-Hz fsk (or 425-Hz nsk) signal is fed through coupling capacitor A3A2C8 to the base of amplifier A3A2Q2. The amplified signal is developed across collector load resistor A3A2R12 and applied through coupling capacitor A3A2C9 to the anodes of switching diodes A3A2CR3 and A3A2CR4.

Voltage divider A3A2R14, R15 biases the anodes of the switching diodes to approximately + 16.5 volts dc. The cathodes of the diodes are connected to voltage dividers that are controlled by front panel MODE SELECTOR switch S4G. Resistors A3A2R16 and A3A2R24 form the voltage divider for switching diode A3A2CR3; resistors A3A2R17 and A3A2R26 form the divider for switching diode A3A2CR4.

Assume that the MODE SELECTOR switch is set at 850 Hz. Ground is supplied from contacts 6 and 1 of switch S4G to resistor A3A2R26. The voltage-divider action of A3A2R26 and A3A2R17 biases the cathode of switching diode A3A2CR4 to approximately \pm 2.5 volts dc. Thus, the diode is forward biased and the signal is applied through the diode, coupling capacitor A3A2C24, 2,000Hz fsk level adjustment potentiometer A3A2R52, and pin 6 of connector A3J1 to terminal 1 of fsk filter FL2.

With no ground applied to resistor A3A2R24, no dividing action takes place and +20 volts dc supply voltage is applied to the cathode of switching diode A3A2CR3 through resistor A3A2R16. Consequently, the diode is reverse biased, which blocks the signal from being applied through series-dropping resistor A3A2R23 and pin 4 of connector A3J1 to nsk filter FL1. With the modem in the 85-Hz diversity mode of operation, the reverse action takes place, and the signal is applied to nsk filter FL1 and blocked from fsk filter FL2. The outputs of the nsk and fsk filters are applied to tty amplifier A3A2Q6 (para 1-51).

1-50. TRANSMIT VOICE CIRCUITS (fig. FO-10)

Transmitter module A3 contains microphone bias, attenuator and keying circuits used in the 50-ohm microphone voice path, and a 600-ohm voice amplifier used in the 600-ohm voice circuit. Figure FO-11 shows the external switch paths used to route signals through the voice circuits.

Transmitter module A3 50-ohm microphone circuits function only during the 85-Hz plus voice modes of operation of the modem. Resistor A3A2R38 provides dc bias voltage for microphone operation, and audio from the microphone is routed through pin 12 of connector A3J1 and coupling capacitor A3A2C20 to an attenuator circuit composed of resistors A3A2R39, A3A2R53, and potentiometer A3A2R40. A portion of the signal that appears across 50 MIKE LEVEL potentiometer A3A2R40 is passed through coupling capacitor A3A2C21 to the anode of keying switch diode A3A2CR8. If the keying diode is forward biased, the audio signal is fed through isolating resistor A3A2R46, coupling capacitor A3A2C23, and pin 10 of connector A3J1 to transmit voice filter FL3. Keying switch diode A3A2CR8 prevents microphone audio from being applied to transmit voice filter FL3 unless a ground is supplied on pin 11 of A3J1 (keyline). Resistors A3A2R41 and A3A2R42 form a voltage-divider network which biases the anode of diode A3A2CR8 at approximately + 18.5 volts dc. The cathode of the diode is connected to a voltage divider composed of resistors A3A2R44, A3A2R43, and A3A2R45. With no ground applied on the keyline, +20 volts dc is applied to the cathode of diode A3A2CR8 through resistor A3A2R45, reverse biasing the diode. When a ground is applied to A3A2R44, the voltage-divider action of resistors A3A2R44, A3A2R43, and A3A2R45 develop approximately + 8.5 volts dc on the cathode of the diode, which forward bias it and allows audio to pass. Capacitor A3A2C22 prevents audio from appearing on the keyline.

The 600-ohm voice circuit (fig. FO-11) operates only in the voice or 85-Hz plus voice modes of operation of the modem. The circuit consists of conventional common-emitter amplifier A3A2Q8, supplied by an audio input signal from pin 18 of connector A3J1. The amplified signal is routed to pin 21 of A3J1 and switch S4G. In the voice mode of operation, the audio is applied through the switch to transmit output amplifier A3A2Q7. In the 85-Hz plus mode of operation, the amplified audio is returned to Pin 23 of A3J1, coupled through isolating resistor A3A2R60 and fed to transmit voice amplifier FL3 through A3J1-20.

1-51. OUTPUT AMPLIFYING CIRCUITS

Output amplifying circuits (fig. FO-10) include three conventional class A, common-emitter amplifiers: tty amplifier A3A2Q6, voice filter amplifier A3A2Q9, and transmit output amplifier A3A2Q7. Tty tones from nsk filter FL1 or fsk filter FL2 are applied through A3J1-2 to the base of tty amplifier A3A2Q6. The amplified tty tone signal is applied through coupling capacitor A3A2C29 and temperature compensating thermistor A3A2RT1 to the base of transmit output amplifier A3A2Q7. In the 85-Hz plus voice mode of operation, audio from transmit voice filter FL3 is applied through A3J1-25 to the base of voice filter amplifier A3A2Q9. The amplifier recovers filter losses and isolates the voice and tty channels. The amplified 200 to 2,260-Hz output of the amplifier is fed through capacitor A3A2C31 to the base of transmit output amplifier A3A2Q7. Transmit output amplifier A3A2Q7 amplified both the voice and tty signals and applies them, through coupling capacitor A3A2C30 and A3J1-1, to output transformer A6T1.

Section VII. STAGE ANALYSIS, RECEIVE SIGNAL PATHS

1-52. INTRODUCTION

This section presents detailed stage analysis of the modem receive circuits -including receiver module A4, receive audio module A1, and scope module A2. Loop battery module A5, which is common to both transmit and receive signal paths, was discussed in paragraph 1-43. The +20 volt regulator portion of receive audio module A1 is discussed in paragraph 1-63. With these exceptions, the discussion of the circuits have been limited to a module basis. Signal flow between the receive signal path modules is covered in the detailed block diagram discussion. Figure FO-8 is the overall schematic diagram of the modem. Refer to it for the details of signal paths between modules and for switch connections.

1-53. RECEIVE INPUT ISOLATION AMPLIFIERS (fig. FO-8)

Board A7 contains two identical Isolation amplifiers which insure separation of the receive voice channel from the receive tty channel, and provide a constant input impedance. Input signal is applied through coupling capacitor A7C3. Resistors A7R7 and A7R14, in conjunction with A7R15, provide channel separation and attenuate the input level. Base bias is supplied through A7R8, R10 or A7R16, R12; collector bias through A7R9 or A7R17. Dc stabilization is insured by emitter resistor A7R11 or A7R13. The output is applied to the tty channel through coupling capacitor A7C4 and to the voice channel through coupling capacitor A7C5.

1-54. RECEIVE AUDIO MODULE A1 (fig. FO-12)

Audio Amplifier Circuit. In 85-Hz plus voice mode of operation, audio from an associated radio receiver is applied through MODE SELECTOR switch S4E to receive voice filter FL5. After filtering, the audio is again applied through the MODE SELECTOR switch and AUDIO GAIN control R1 to receive audio module A1. In the voice mode of operation, audio from an associated receiver is applied directly to receive audio module A1 through AUDIO GAIN control R1. In receive audio module A1, the audio input signal is amplified by driver A1A1Q1 and applied to push-pull audio output amplifier A1Q2, Q3. Potentiometer A1A1R10 allows balance of the bias of transistors A1Q2 and A1Q3 to minimize output distortion. The output of the amplifier is coupled to audio transformer A1T1 and the transformer output is coupled to attenuating network A1A1C8, A1A1R17, and A1A1R18, which provides a 2-watt output to a loudspeaker and a 600-ohm, 10-mw output for driving a headset or handset.

Squelch Circuit. A portion of the audio input signal is applied to detector A1A1CR1, Q2 through SQUELCH SENS potentiometer R9. With audio applied, detector A1A1CR1, Q2 is forward biased by the positive portion of the audio signal. Inverse amplifier A1A1Q3 then conducts, biasing threshold zener diode A1A1VR1 below the firing point. Thus, squelch switch A1A1Q4 remains turned off, and the circuit is un-squelched. When audio is removed, detector A1A1CR1, Q2 cuts off. However, inverse amplifier A1A1Q3 remains conducting because of the negative charge on capacitor A1A1C7. Capacitor A1A1C7 discharges through the forward resistance of inverse amplifier A1A1Q3. When capacitor A1A1C7 is fully discharged, inverse amplifier A1A1Q3 cuts off, firing threshold zener diode A1A1VR1 and gating on squelch switch A1A1Q4. This effectively grounds the input to driver A1A1Q1 through capacitor A1A1C4, which is a low impedance to noise at audio frequencies, and the circuit is squelched. The circuit remains squelched until audio is again applied, at which time detector A1A1CR1, A1A1Q2 is again forward biased and squelched switch A1A1Q4 is turned off.

Mixer Injection Frequency Circuits.

- **General.** Depending on the mode of operation of the modem, the mixer injection frequency circuit provides either a frequency within the range from 3,805 to 5,805 Hz (850-Hz mode of operation) or an amplified 2,380-Hz frequency (85-Hz diversity operation). The output is applied to receiver mixer injection amplifier A4A1Q1.
- **850-Hz mode of operation of the Modem.**
- **General.** During 850-Hz mode of operation, the mixer injection frequency is developed by BFO A1A3Q1, amplified, by driver A1A2Q3, divided by divide-by-2 bistable multivibrator A1A2Q4, Q5, and amplified by mixer injection amplifier A1A2Q6. When front panel MODE SELECTOR switch S4 is set at 850 Hz, +20 volts dc is applied through pin 1 of connector A1J1 to energize the BFO, driver and multivibrator circuits. The +20 volts dc is also applied to BFO tune control R2 (fig. FO-8). A portion of the voltage across R2 is applied to the BFO through voltage divider A1A2R6, A1A2R7.

- **Beat frequency oscillator.** Unijunction transistor A1A3Q1 forms a voltage-controlled relaxation oscillator, the frequency of which increases as the voltage from BFO control R2 is increased. Positive 20 volts dc, applied through bias resistor A1A3R1, back biases the PN diode junction that effectively exists between the emitter (E) and base 1 (B1). Capacitor A1A3C1 charges towards the positive voltage from BFO control R2 through voltage divider A1A2R6, A1A2R7. When the voltage across capacitor A1A3C1 reaches the firing potential of the unijunction transistor, the E-B1 diode becomes forward biased and the capacitor discharges through the transistor and load resistor A1A3R2. This results in a positive-going spike across A1A3R2, which is applied through coupling capacitor A1A2C6 to the base of driver A1A2Q3. Charging time of capacitor A1A3C1 depends on the magnitude of the voltage applied to it; with a higher voltage applied, less time is required to reach the firing potential of the unijunction transistor and the oscillator output frequency is increased. A thermostatically controlled heater maintains the unijunction transistor at a uniform temperature, to minimize drift in the oscillator output frequency.
- **Driver and dividing circuits.** Driver A1A2Q3 amplifies the oscillator output and couples the resulting negative-going spike waveform to divide-by-2 multivibrator A1A2Q4, Q5. Divide-by-2 multivibrator A1A2Q4, Q5 is a conventional bistable multivibrator which generates a square wave output at one-half the input (oscillator) frequency. The multivibrator output is fed through coupling capacitor A1A2C12 and isolating resistor A1A2R18 to the base of mixer injection amplifier A1A2Q6, which amplifies the 3,805-to 5,805-Hz signal and applies it to receiver mixer injection amplifier A4A1Q1.
- **85-Hz diversity mode of operation of Modem.** During the 85-Hz diversity mode of operation, the 3,805 to 5,805-Hz frequency is not generated because no operating voltage is supplied to the BFO driver and multivibrator circuits from MODE SELECTOR switch S4. Instead, a 2,380-Hz signal from transmitter module A3 is fed through pin 10 of connector A1J1, coupling capacitor A1A2C11, and isolating resistor A1A2R17 to the base of mixer injection amplifier A1A2Q6. This signal is not generated during the 850-Hz mode of operation.

+20 Volt Regulator Circuit. Although physically located in audio module A1, the +20 volt regulator circuit is functionally a part of the power supply circuits. Consequently, the circuit is discussed in paragraph 1-66.

1-55. RECEIVER MODULE A4 (fig. FO-13)

The receiver module consists of those mixing, switching, and demodulating circuits necessary to convert received tty tone signals into mark and space pulses for use by loop battery module A5. The circuits are divided into categories and are discussed separately. The mixer and amplifying circuits are discussed below.

Tty Channel 1. Nsk or fsk audio from fsk and nsk filtering is fed through pin 12 of connector A4J1 to a mixer circuit consisting of diodes A4A1CR1, CR2; capacitors A4A1C2, C3; resistors A4A1R5, R6; and transformer A4A1T1. Diodes A4A1CR1, CR2 provide the nonlinear circuit elements necessary for mixing. A 2,380-Hz (during 85-Hz diversity mode of operation) or 3,805 to 5,805-Hz (during 850-Hz mode of operation) signal from receive audio module A1 (para 1-54) is amplified by mixer injection amplifier A4A1Q1 and coupled through capacitor A4A1C4 to the mixer circuit. The resulting mixer products sum and difference are applied to nsk and fsk filters. All products, except 2,805-Hz \pm 42.5 (nsk) or 2,805-Hz \pm 425 (fsk), are filtered at this point. After filtering, the signal is returned through pin 7 of connector A4J1, amplified by amplifier A4A1Q2, and limited by A4A1Q3. Limiter amplifier A4A1Q3 assures that the signal level applied to the fsk nsk discriminator through discriminator driver A4A1Q4 remains constant despite varying input signal levels.

RECEIVER MODULE MIXER, MIXER INJECTION AMPLIFIER AND NSK, FSK FILTER SWITCHING

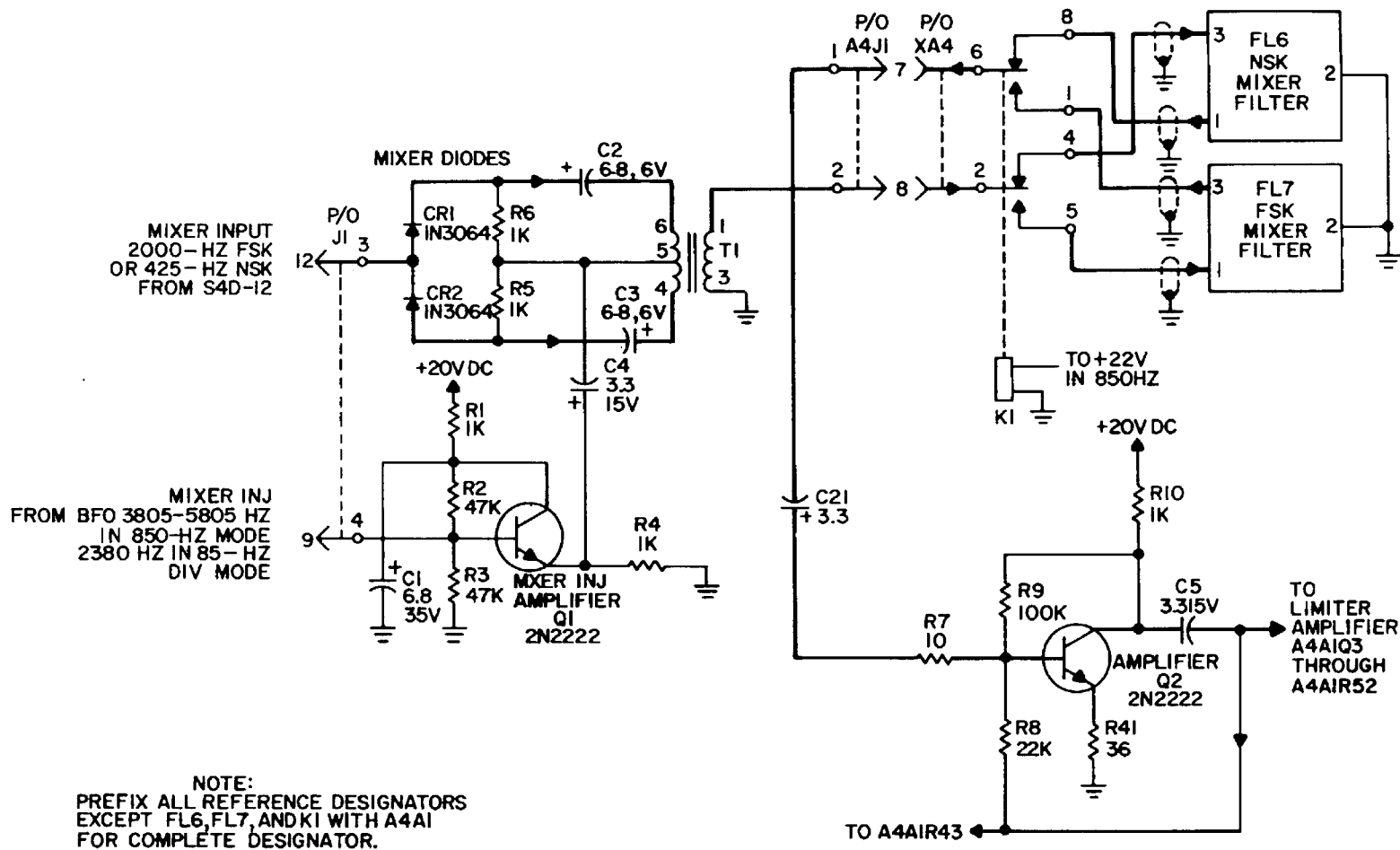

Tty Channel 2. Channel 2 nsk tones are applied through pin 15 of connector A4J1 (fig. FO-5) amplified by amplifier A4A2Q2, limited by limiter amplifier A4A2Q5, and applied to the nsk only discriminator through discriminator driver A4A1Q6. Because the input tone is centered at 2,805 Hz, no mixing is necessary before the input signal is fed to the discriminator.

1-56. FREQUENCY DISCRIMINATOR CIRCUITS

The two frequency discriminator circuits demodulate fsk and nsk mark and space tones, and provide differential voltages which are a function of the input frequency (mark or space tone frequency). Each frequency discriminator develops a differential voltage of one polarity for a mark tone frequency input and one of the opposite polarity for a space tone input frequency. The differential voltages are applied to mark-space generation circuitry (para 1-57), which converts the differential voltages into mark and space pulses. The two discriminator circuits are identical, except that the pass band of fsk/nsk frequency discriminator A4A1Q9, Q10 can be changed to demodulate either fsk tones (mark and space signals 850 Hz apart) or nsk tones (mark and space signals 85 Hz apart), depending on the mode of operation. In the 850-Hz mode, energized relay A4A1K1 switches the connections to fsk/nsk frequency discriminator A4A1Q9, Q10 so that the pass band is widened for fsk operation. In this mode, relay A4A1K1 also reverses the phase-sensing circuit connections of the discriminator so that the higher tone input will eventually produce a mark pulse and the lower tone input will produce a space pulse. This reversal corrects the tone reversal caused by subtractive mixing in mixer A4A1CR1, CR2, T1 (para 1-55). Since fsk/nsk frequency discriminator A4A1Q9, Q10 and nsk frequency discriminator A4A2Q7, Q8 are similar, only the operation of the fsk/nsk discriminator will be discussed.

The discriminator circuit is resonant at 2,805 Hz (the center frequency of the applied signal) and produces a differential voltage for an input frequency above or below resonance. This discriminator circuit differs from the conventional type in that the phase-sensing circuit (A4A1L4, C22, C23, C24) is link-coupled to the secondary of transformer A4A1T2. With this arrangement, the voltage developed across parallel-connected capacitors A4A1C22, C23 at resonance differs 90° in phase from the voltage across the secondary of transformer A4A1T2. Therefore, at resonance, transistors A4A1Q9 and A4A1Q10 will conduct equally, producing equal but opposite voltages so that the sum of their outputs is zero. When the frequency of the incoming signal is above or below resonance, the phase shift across capacitors A4A1C22, C23 is greater or less than 90°, which causes one transistor to conduct more than the other. This results in a differential voltage output which is a function of the phase shift. The output of the frequency discriminator is balanced (ungrounded). Resistor A4A1R29 prevents waveform distortion and causes a drastic reduction in "Q" when the transistors conduct. Because transistors act as switches in only one direction, diodes A4A1CR6 and A4A1CR7 provide a dc return for the collector current of their associated transistors. Resistors A4A1R50 and A4A1R51, in series with the base of each transistor, isolate sensing circuit A4A1L4, C24, C23, C22 from the loading effect of A4A1Q9, Q10.

FREQUENCY DISCRIMINATOR AND SWITCHING, RECEIVER MODULE A4

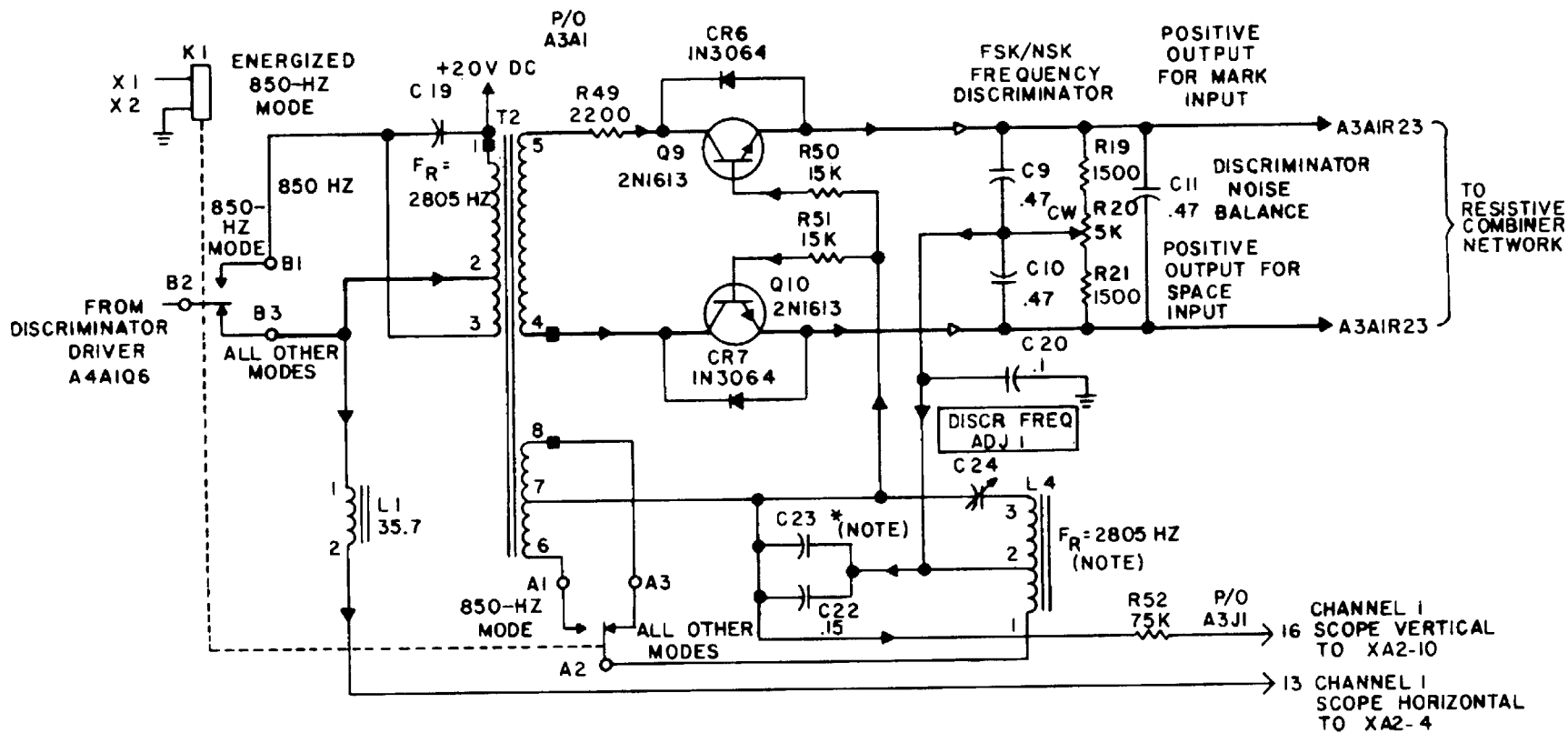

NOTE:
C23 FACTORY SELECTED FOR RESONANCE
(F_R) AT 2805 HZ.

1-57. RECEIVE MARK-SPACE PULSE GENERATION, STAGE ANALYSIS

The output stages of receiver module A4 form the receive mark-space pulse generation circuitry consisting of resistive combiner network A4A1R22, R23, R26, R27; discriminator differential amplifier A4A1Z1; dc bistable multivibrator A4A1Q5, Q6; and ac bistable multivibrator A4A1Q7, Q8. Paragraph 1-29 gives a detailed block diagram discussion of this circuitry.

Resistive Combiner Network. The resistive combiner network isolates the output of tty channel 1 frequency discriminator A4A1Q8, Q9 from that of tty channel 2 frequency discriminator A4A2Q5, Q6 in all modes except 85-Hz diversity. In 85-Hz diversity, the outputs of tty channels 1 and 2 are combined at this point. The input to the resistive combiner network is a varying dc from the frequency discriminator, the polarity of which depends on the frequency of the input (that is, a mark or space tone). The difference of potential is about 2 volts, dropping to zero in the absence of signal input.

Discriminator Differential Amplifier. Discriminator differential amplifier A4A1Z1 is an integrated circuit dc amplifier connected as a differential amplifier. Circuit details are shown in note 5 of the overall receiver module schematic diagram (fig. FO-13). A voltage divider consisting of A4A1 R42, R28, and R29 supplies a +13.2 volt input to terminal 9 of A4A1Z1. A +6.6 volt dc bias from the same voltage divider is applied to terminal A4A1Z1-2. Terminals 1 and 6 receive their bias from the 6.6 volt-source through resistors A4A1R24 and A4A1R25, respectively. Capacitor A4A1d25 cancels noise and transients at the A4A1Z1 input. A mark tone input to the modem produces a discriminator output so that discriminator differential amplifier terminal A4A1 Z1-1 is positive with respect to terminal A4A1Z1-6. When this condition occurs, A4A1Z1 output terminal 10 is in high state (more positive than output terminal 8). Conversely, a space tone input to the modem produces a discriminator output so that terminal A4A1Z1-1 is negative with respect to terminal A4A1Z1-6. When this condition occurs, A4A1Z1 output terminal 8 is in high state. The output of the discriminator differential amplifier can be sampled across DISCR AMPL jacks A4A1J2, J3.

Dc Bistable Multivibrator A4A1Q5, Q6 Multivibrator A4A1Q5, Q6 is a conventional dc-coupled bistable multivibrator. Resistors A4A1R45, R44, and R46 form a balance network for the multivibrator input. By adjusting A4A1R44, compensation can be made for differences in level of the output of A4A1Z1. When the output of A4A1Z1-10 is positive, corresponding to a mark, A4A1Q5 is biased into a low state, resulting in a high state for A4A1Q6. Conversely, a positive output from terminal A4A1Z1-8 switches A4A1Q6 to a low state, with A4A1Q5 at high state. Note that A4A1Q6 can be locked in low state through tty squelch switch A4A1Q1 (mark hold condition) as described in paragraph 1-65.

Ac Bistable Multivibrator A4A1Q7, Q8 Multivibrator A4A1Q7, Q8 is a conventional ac-coupled bistable multivibrator. When A4A1Q5 is in a high state (corresponding to a mark), A4A1Q7 is held in a high state through A4A1C18. Thus, a positive voltage appears at receiver module output A4J1-24, corresponding to a normal mark. At the same time, A4A1Q8 is held in a low state, so ground appears at receiver module output A4J1-23, corresponding to a reverse mark. A space input to the modem would result in a ground at A4A1-24 and a positive voltage at A4A1-23.

RECEIVER MODULE A4, OUTPUT STAGES

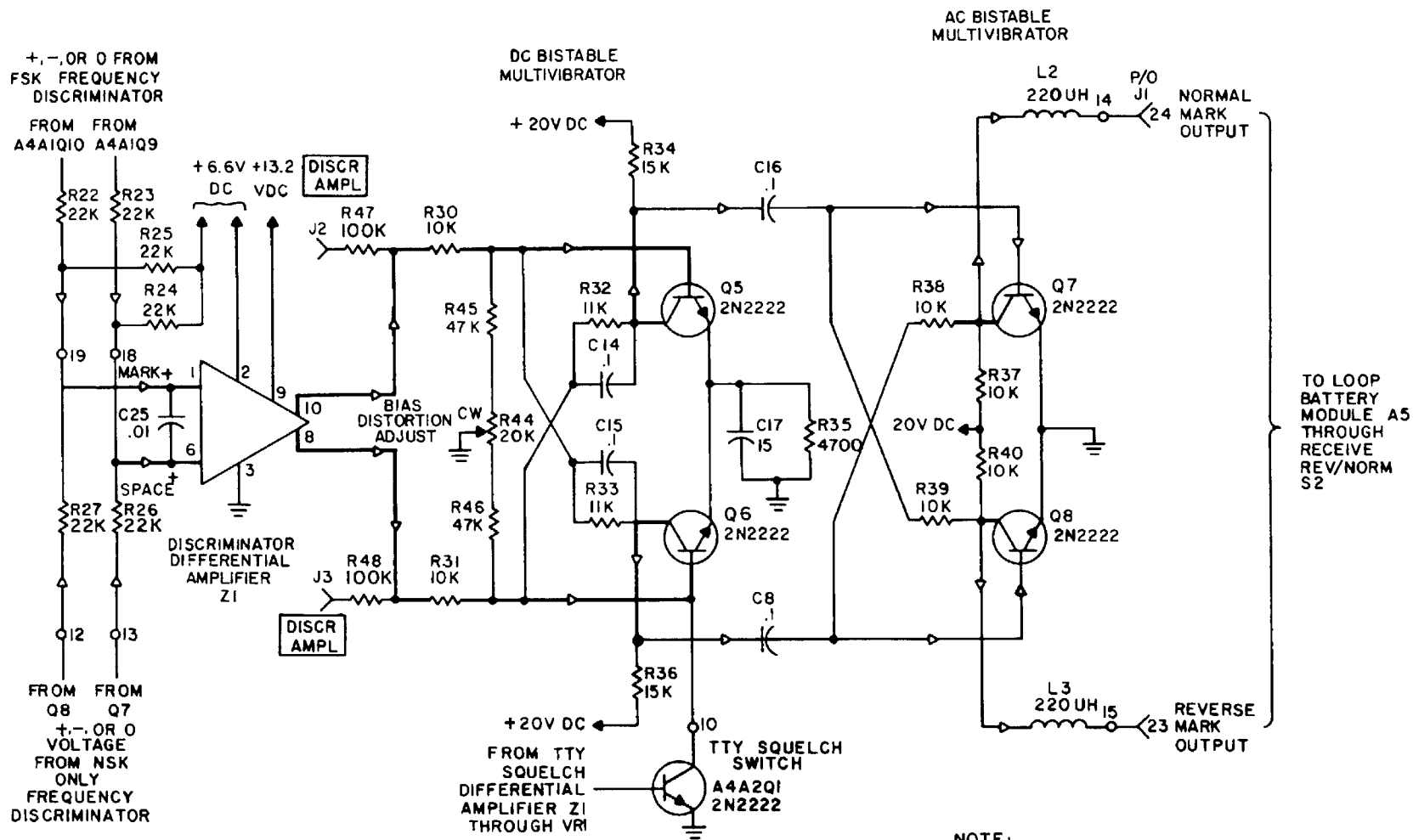

NOTE:
PREFIX ALL PARTIAL REFERENCE DESIGNATORS WITH "A4A1"

1-58. DIVERSITY SWITCHING

During 85-Hz diversity operation, the diversity switching circuit automatically selects the tty channel with the greater signal strength and squelches the weaker channel. However, if the levels of both channels are within 3 db, the outputs of both channels are combined. During 850-Hz operation, the circuit squelches channel 2, and during 85-Hz and 85-Hz plus voice modes, squelches channel 1. Operation of both channels is similar. Channel 1 is described below, and differences between channels are noted where necessary.

Resistors A4A1R43, A4A2R5, and A4A2R32 form a voltage divider for the amplified tty channel 1 signal. A portion of the signal that appears across potentiometer A4A2R5 is applied through coupling capacitor A4A2C4 to channel 1 detector network A4A2CR3, A4A2CR4, A4A2C5, and A4A2R6. The detector network provides a positive dc voltage at the junction of A4A2C5 and A4A2R6 that is proportional to the input signal. This dc voltage is applied to pin 1 of differential amplifier A4A2Z2. The dc voltage from the channel 2 detector network is applied to pin 6 of the differential amplifier.

Differential amplifier A4A2Z2 is an integrated circuit differential amplifier. When the dc level applied to pin 1 exceeds that applied to pin 6 by approximately 3 db, the dc level of output pin 8 will approach the + 10.7 volt dc supply voltage and the dc level of output pin 10 will be low. The opposite condition exists if the dc level on pin 6 (channel 2) exceeds that on pin 1. With pin 8 high, threshold zener diode A4A2VR4 conducts and the voltage drop across bias resistor A4A2R16 causes channel 2 switch A4A2Q4 to conduct. The low impedance of the conducting transistor effectively grounds the base of limiter amplifier A4A2Q5, blocking the channel 2 output. The low level at pin 10 of differential amplifier A4A2Z2 prevents threshold zener diode A4A2VR5 from conducting, and keeps channel 1 switch A4A2Q3 cut off.

Channel 2 is squelched during 850-Hz operation by +22 volts dc applied to the base of channel 2 switch A4A2Q4 through bias resistor A4A2R39. This biases the transistor on. Similarly, channel 1 is squelched during the 85-Hz and 85-Hz plus voice modes by +22 volts dc applied through bias resistor to channel 1 switch A4A2Q3 through A4A2R40.

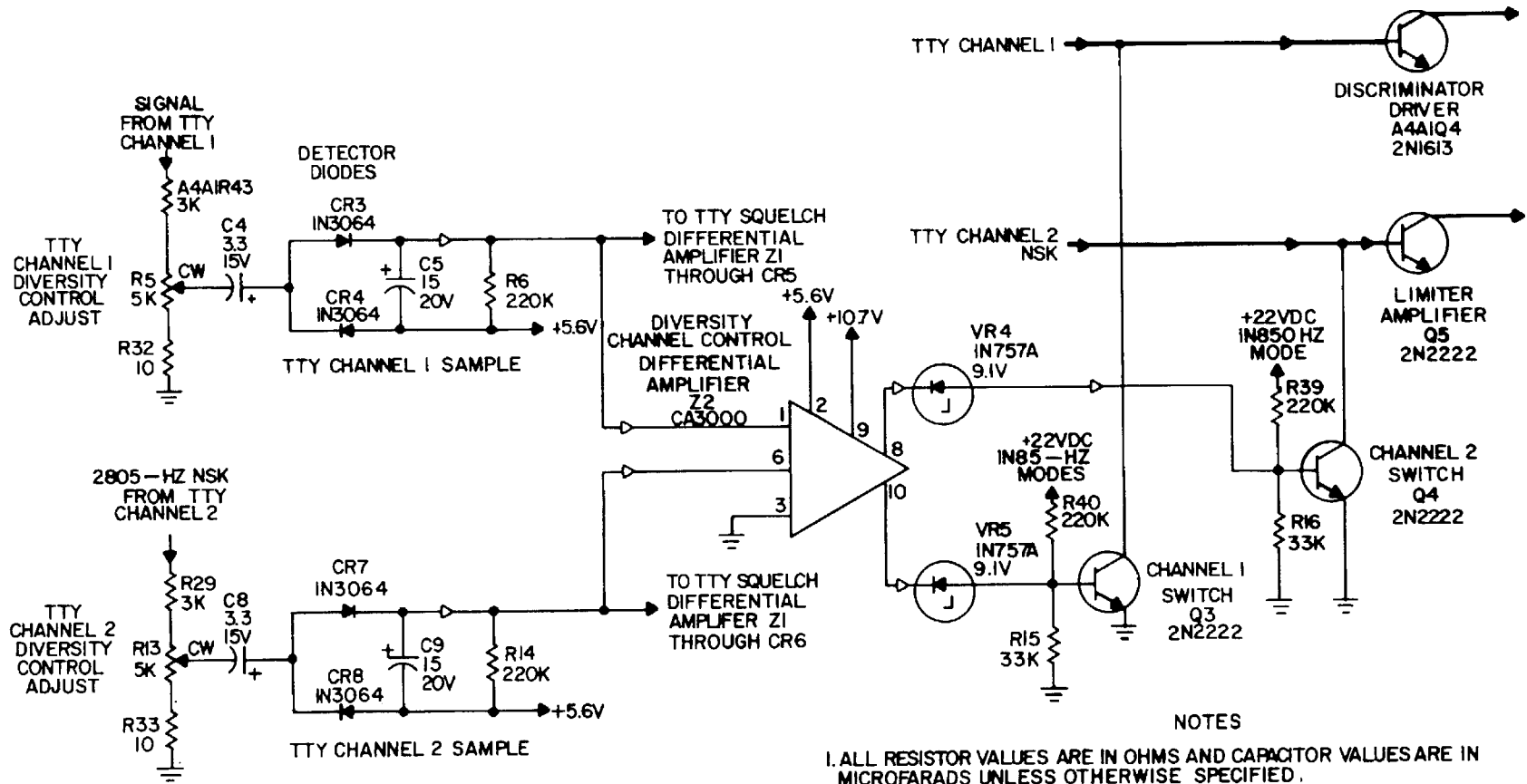

NOTES

1. ALL RESISTOR VALUES ARE IN OHMS AND CAPACITOR VALUES ARE IN MICROFARADS UNLESS OTHERWISE SPECIFIED.
2. PREFIX ALL PARTIAL REFERENCE DESIGNATORS WITH "A4A2"
3. Z2 IS AN INTEGRATED CIRCUIT DIFFERENTIAL AMPLIFIER FOR DETAILS, SEE NOTE 5, RECEIVER MODULE SCHEMATIC.
4. HEAVY LINE ——— INDICATES MAIN SIGNAL PATH. CLOSED ARROWHEAD — ON SIGNAL PATH INDICATES AC SIGNAL SUCH AS FSK AND NSK TONES. OPEN ARROWHEAD — INDICATES VARYING DC, OR DC PULSES.

DIVERSITY SWITCHING, RECEIVER MODULE A4

1-59. MARK HOLD SWITCHING

The mark hold switching circuit compares the noise in the unfiltered, audio input signal with the filtered tty signal. When signal to noise is excessive, the channel is squelched. Unfiltered signal plus noise is applied to a voltage divider consisting of potentiometer A4A2R1 and either resistor A4A2R30 or A4A2R31, depending on the setting of front panel MODE SELECTOR switch S4. Resistor A4A2R30, used during the 850-Hz mode, is a much lower value than resistor A4A2R31, to compensate for the greater noise that is present in the wider bandwidth signal.

A portion of the voltage that appears across potentiometer A4A2R1 is applied through coupling capacitor A4A2C2 to detector network A4A2CR1, A4A2CR2, A4A2C3, and A4A2R2. The detector network provides a positive dc voltage at the junction of A4A2C3 and A4A2R2 that is proportional to the signal-plus-noise input. This dc voltage is applied to differential amplifier A4A2Z1.

Dc voltages proportional to the filtered and rectified signals present in tty channels 1 and 2 are applied to the anodes of diodes A4A2CR5 and A4A2CR6, respectively. Diodes A4A2CR5 and A4A2CR6, and cathode load resistor A4A2R3 form an auctioneer (OR gate) circuit referenced to + 5.6 volts dc. The greater voltage applied to diodes A4A2CR5 and A4A2CR6 will cause the appropriate diode to conduct, and the resulting voltage drop across A4A2R3 is applied to differential amplifier A4A2Z1.

Differential amplifier A4A2Z1 is an integrated circuit differential amplifier identical with A4A2Z2 with internal circuitry arranged so that pin 8 is low as long as the dc signal on pin 1 does not exceed the signal on pin 6 by more than a small amount. Because the dc voltage applied to pin 1 also includes the noise component of the input signal and the dc voltage applied to pin 6 is derived from a signal with the noise filtered out, when excessive noise is received the voltage at pin 1 will exceed that at pin 6, and pin 8 of differential amplifier A4A2Z1 will approach the + 10.7 volt dc supply voltage. This causes zener diode A4A2VB1 to conduct. The amount of noise which is considered excessive depends on the mode of operation. Because of the wide-band operation in fsk, the signal-to-noise ratio which initiates the squelching action is between 3 and 6 db. In all 85-Hz modes, the ratio is between 6 and 9 db. The sensitivity of the tty squelch depends on whether low value resistor A4A2R30 (85-Hz mode) or high value resistor A4A2R31 (all 85-Hz modes) is used as the path to ground for tty squelch adjust A4A2R1.

When zener diode A4A2VR1 conducts, the voltage drop across bias resistor A4A2R4 causes tty squelch switch A4A2Q1 to conduct, presenting a low level to dc bistable multivibrator A4A1Q5, Q6. Capacitor A4A2C23 bypasses resistor A4A2R4 to enhance rapid turn on of switch A4A2Q1. With front panel AUTO MARK HOLD switch S6 set at OFF, the base of switch A4A2Q1 is grounded, preventing the transistor from conducting.

MARK HOLD SWITCHING, RECEIVER MODULE A4

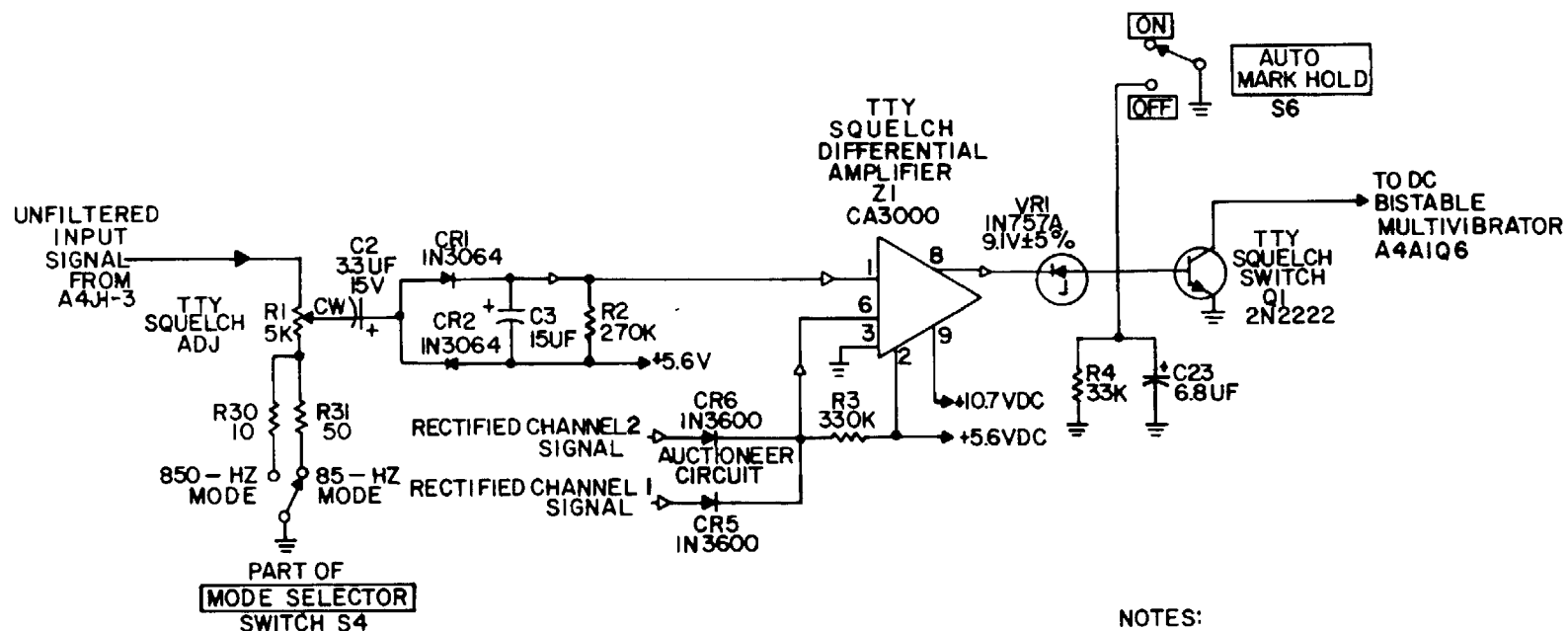

NOTES:

1. ALL RESISTOR VALUES ARE IN OHMS UNLESS OTHERWISE SPECIFIED
2. S 4 AND S6 ARE LOCATED ON FRONT PANEL
3. FOR FULL REFERENCE DESIGNATORS FOR COMPONENTS OTHER THAN S4 AND S6, PREFIX WITH 'A4A2'
4. ARROWHEAD → ON SIGNAL PATH INDICATES AC SIGNAL SUCH AS FSK AND NSK TONES. OPEN ARROWHEAD ⇨ INDICATES VARYING DC, OR DC PULSES.

1-60. SCOPE MODULE A2 (fig. FO-14)

The scope module displays the phase relations between the mark and space signals in tty channel 1 or 2. The scope module consists of amplifying and channel switching, intensity squelch and power supply circuits. The amplifying and channel switching are discussed below.

General. Amplification of horizontal and vertical input signals is provided by amplifiers A2A1Q1 and A2A1Q2, respectively. Voltages from mark and space tones in the frequency discriminators of receiver module A4 are applied to the scope amplifiers.

Channel Switching. Voltages from the fsk/nsk discriminator are applied to channel 1 input; those from the nsk only discriminator are applied to channel 2 input. The voltages are coupled through contacts of relay A2A1K1, which selects the channel to be displayed. Relay A2A1K1 contacts normally connect the channel 2 inputs to the amplifiers. The relay is controlled by channel switch A2A1Q5. When channel 2 is squelched during 850-Hz mode of operation, or because a stronger signal exists on channel 1 during 85-Hz diversity mode of operation, +20 volts dc is supplied through pin 6 of connector A2J1 to zener diode A2A1VR1. Zener diode A2A1VR1 conducts and biases on channel switch A2A1Q5. Collector current of A2A1Q5 energizes relay A2A1K1, connecting the channel 1 input to the horizontal and vertical amplifier paths.

Horizontal Amplification. Horizontal input signals are applied from contact A2 of relay A2A1K1 and coupling capacitor A2A1C14 to an rc network composed of resistors A2A1R22, R23 and capacitors A2A1C3, C4. This network is one-half of a circuit, which is tuned to 2,805 Hz; this is the center frequency of the frequency discriminators in receiver module A4. The other half of the tuned circuit is a coil connected to the primary of the frequency discriminator being used. In the 850-Hz mode of operation, ground is applied to resistor A3A1R24 to decrease the output amplitude of the network which compensates for greater voltage amplitudes at the fsk discriminator. HORIZONTAL GAIN potentiometer A2A1R8 feeds a portion of the voltage across the tuned circuit to horizontal amplifier A2A1Q1. The output of A2A1Q1 is coupled through transformer A2A1T1 and coupling capacitor A2A2C1 to one horizontal deflection plate of crt A2V1. Capacitor A2A1C17 allows adjustment of the phase of the horizontal voltage to correct phase differences between the horizontal and vertical signals caused by cable capacitance.

Vertical Amplification. Input signals to the vertical channel are applied from contact B2 of relay A2A1K1 to VERTICAL GAIN potentiometer A2A1R13. A portion of the voltage across the potentiometer is fed to vertical amplifier A2A1Q2 which develops two separate outputs. The emitter signal, developed across emitter resistor A2A1R2, is used by the intensity squelching circuit (para 1-61). The collector signal is coupled through transformer A2A1T2 and coupling capacitor A2A2C2 to the vertical deflection plate of the CRT Capacitor A2A1C16 allows the phase of the signal to be adjusted to correct phase differences between the vertical and horizontal signals caused by cable capacitance.

1-61. INTENSITY SQUELCHING

The intensity squelching circuit biases off the display when the signal in the vertical channel falls below a predetermined level. The emitter output of vertical amplifier A2A1Q2 is sampled across SQUELCH ADJ potentiometer A2A1R25 and amplified by transistors A2A1Q4 and A2A1Q3. Thermistor A2A1RT1, in the emitter path of amplifier A2A1Q3, compensates for variations in emitter current gain with temperature. The amplified signal at the collector of A2A1Q3, directly proportional to the output level of vertical amplifier A2A1Q2, is applied to high-voltage isolation transformer A2A1T3. Diodes A2A2CR4, CR5 and capacitor A2A2C9 form a full-wave rectifier which develops a dc level proportional to the signal coupled through transformer A2A1T3. This dc level is applied to the base of squelch switch A2A2Q1, causing the transistor to conduct. Squelch switch A2A2Q1 is connected between the wiper (A2J1-3) of SCOPE INTENSITY control R3 and its negative most end (A2J1-1). When A2A2Q1 is conducting, the portion of R3 between the wiper and the negative most end is shorted out, causing a more positive voltage to be applied to control grid, pin 2 of V1. As R3 is rotated clockwise, the scope intensity becomes brighter; counterclockwise rotation dims the intensity. When the vertical input signal level falls below a level sufficient for good display, the amplified signal across transformer A2A2T1 cannot develop a dc level large enough to keep squelch switch A2A2Q1 conducting. Consequently, switch A2A2Q1 cuts off and the full -900 volt potential is applied to the control grid of the crt, squelching the display. The collector of A2A2Q1 is returned to -750 volts through SCOPE INTENSITY control potentiometer A2R3, which allows adjustment of emitter current flow and resulting display intensity.

1-62. POWER SUPPLY

High voltage for the crt bias circuit is provided by the scope power supply, which consists of a dc-to-ac inverter, a voltage doubler, and a divider network. The dc-to-ac inverter consists of oscillator A2Q1, Q2, and A2T1, starting resistor A2A2R13, feedback diode A2A2CR3, rfi filter A2A2C8, L1, slow-down circuit A2A2C6, C7, and overvoltage zener diodes A2A2VR3 and VR4. Except for the overvoltage zener diodes, the circuit is identical with the dc-to-ac inverter of power supply module A5, and operates as described in paragraph 1-40. Overvoltage zener diodes A2A2VR3 and VR4 limit the collector voltages of transistors A2Q1 and A2Q2 to +68 volts, preventing the emitter-collector voltage ratings of the transistors from being exceeded. Transformer A2T1 provides a 12 volt, peak-to-peak heater voltage for the crt and a 1,000 volt output is divided by deflection supply voltage-divider chain A2A2VR1, VR2 and resistors A2A2R5 through R9. Potentiometers A2A2R2 and A2A2R4 are connected between the + 100 and -100 volt potential points, to allow centering of the vertical and horizontal scope traces.

Section VIII. POWER SUPPLY STAGE ANALYSIS AND SWITCHING

1-63. GENERAL (fig. FO-15)

This section presents a detailed discussion of the various stages of the main power supply and the operational control circuitry which switches it. The main power supply consists of PRIMARY POWER connector input Jack J8, circuit breaker CB1, a transient suppressor, a +22-volt preregulator, a +20-volt regulator, and MODE SELECTOR switch S4F. The special purpose power supplies in modules A2 and A5 are discussed in paragraph 1-62 and 1-40, respectively.

1-64. POWER INPUT AND TRANSIENT SUPPRESSOR STAGE ANALYSIS (fig. FO-15)

The transient suppressor consists of polarity diode A9CR1, overvoltage reference A9VR1, switches A9Q1, Q2, Q3, CR2, and zener diode VR7 and associated resistors and capacitors. The transient suppressor protects against overloads, reverse polarities, and transient voltages which would cause damage to the following circuitry.

Reverse Polarity. When the 27 volt supply is connected backwards, polarity diode A9CR1 conducts, tripping circuit breaker CB1. The auxiliary power output is not protected by CB1.

Overvoltage Protection. When the primary power exceeds 33 volts (± 5 percent), overvoltage reference zener A9VR1 conducts, forward biasing switch Q1, which reverse biases switch A9Q2. This action causes the voltages at the Junction of A9R4, R5 to rise, charging A9C1 through A9R4, R5. (Normally, A9Q2 is forward biased, grounding A9C1 through A9R5.) Transistor A9Q3 is silicon unilateral switch (SUS) which has a discrete switching voltage. When not conducting, the impedance of A9Q3 is high, but when its switching voltage is reached, the impedance is low. If the duration of the overvoltage is long enough to damage following circuitry, A9C1 charges through A9R4 and A9R5 to the switching voltage of A9Q3 (8 ± 2 volts). Transistor A9Q3 conducts, applying a gating voltage to silicon-controlled (scr) switch A9CR2. When A9CR2 is gated on, the overvoltage input to the modem is grounded through A9R7. The excess current drawn trips CB1.

Transient Protection. If a high-voltage transient of short duration is applied to the modem, A9C1 may not have time to charge through the overvoltage protection circuitry before the following circuitry is damaged. The following circuitry can accept transients up to 115 volts, but protection is required against transients of higher voltages. When a transient exceeds 110 volts (± 5 percent), A9VR7 conducts, rapidly charging A9C1 through A9R7. (Note that the charge time through low value resistance A9R7 is faster than through high value resistors A9R4, R5.) When C1 reaches the switching voltage of A9Q3, scr switch A9CR2 is gated on, and circuit breaker CB1 is tripped as described above.

1-65. +22-VOLT PREREGULATOR (fig. FO-15)

The +22-volt preregulator consists of reference zeners A9VR3, VR5, VR6; comparator A9Q5; amplifier Q3; series regulators Q1, Q2; transient protectors CR1, A9VR4; and associated resistors and capacitors. Zener A9VR3 provides an 18 volt (± 5 percent) reference voltage to voltage divider A9RT1, R11, R12. The +22V ADJ control A9R11 adjusts the voltage of the preregulator output from 20 to 24 volts. The preregulator output is sampled through series diodes A9VR5, VR6, which maintain a constant voltage drop of 8.4 volts from the +22 volt output. As loading or other factors cause the preregulator output voltage to drop, the voltage drop across emitter resistor A9R9 is lowered, forward biasing comparator A9Q5. This action causes A9Q5 to conduct more, lowering the base voltage of amplifier Q3 with respect to its emitter. Amplifier Q3 conducts more, raising the base voltage of series regulator Q1, Q2. Series regulator Q1, Q2 conducts more, raising the output voltage of the preregulator and compensating for the original drop in output voltage. The unit operates the opposite way to counter a rise in output voltage. Transistors Q1 and Q2 are paralleled to provide required current capacity. Diode CR1 prevents collector-to-emitter breakdown of Q1, Q2 due to starting transients. Zener diode A9VR4 grounds out transients exceeding 27 volts. The capacitance of A9C2 multiplied by the betas of A9Q5 and Q3, filters noise. Capacitor A9C3 filters out low-voltage transients and noise. Starting resistor R8 provides a voltage source to A9VR3 to start the preregulator.

A short across the output of the preregulator will not trip circuit breaker CB1. The preregulator provides its own short-circuit protection. A short across the preregulator output drops the voltage across reference diode A9VR3 to zero; therefore, comparator A9Q5, amplifier Q3, and series regulator Q1, Q2 are sequentially cut off. When the short is removed, A9R8 applies the starting voltage to reference zener A9VR3. Thus, a short circuit at the output of the preregulator cannot trip circuit breaker CB1. However, shorts in circuitry beyond the preregulator output can trip the circuit breaker if they draw a current that exceeds 2.6 amperes. The preregulator +22 volts is applied to MODE SELECTOR switch S4 (para 1-67) and the 20 volt regulator (para 1-66).

1-66. TWENTY-VOLT REGULATOR (fig. FO-15)

The 20 volt regulator in receive audio module A1 provides a +20 volt dc regulated output to all circuits for appropriate operating settings (850 HZ, 85 HZ, VOICE, 85 HZ DIV, and 85 HZ+ VOICE) of MODE SELECTOR switch S4. Twenty-two volts dc is applied to series regulator A1Q1. The effective collector-to-emitter resistance of A1Q1, in series with the 22 volt dc line, drops the voltage to +20 volts dc for any given current required by the applicable circuits. Comparator A1A2Q2 compares the output level with a level established by reference zener A1A2VR1. The circuit is adjusted by +20V REG ADJ A1A2R4 so that the output is maintained at +20 volts dc ± 0.2 . The difference between the voltage standard and 20 volt dc output is raised in level by comparator A1A2Q2 and applied to amplifier A1A2Q1. Dc amplifier A1A2Q1 is direct-coupled to series regulator A1Q1; therefore, the conduction of A1Q1 is controlled by the conduction of A1A2Q1. Thus, the output of dc amplifier A1A2Q1 will alter the amount of conduction (effective collector-to-emitter resistance) of series regulator A1Q1 causing the output voltage to be maintained at +20 volts dc. The +20 volts output is applied to all modules (A1, A2, A3, A4, A5), board A7, and MODE SELECTOR switch S4F.

1-67. OPERATIONAL CONTROL CIRCUITS (fig. FO-15)

MODE SELECTOR Switch. Wafer F of MODE SELECTOR switch S4 switches regulator +20 volts (para 1-66) and preregulated +22 volts (para 1-65) to relays and circuits within modules that must operate only in certain modes. The routing of +20 and +22 volts is discussed below and in paragraphs 1-68 through 1-71.

850-Hz Operation. When MODE SELECTOR switch S4 is set at 850 HZ, + 22 volts, + 20 volts, and ground are applied to the appropriate circuit as follows:

- The +22 volts dc from the preregulator is applied through contacts 12 and 7 of MODE SELECTOR switch S4F to pin 25 of receiver module connector XA4, A4J1. The +22 volts energizes relay A4A1K1, modifying operation of frequency discriminator A4A1Q9, Q10 for the fsk tones in the 850-Hz mode. The +22 volts also forward biases channel 2 switch A4A2Q4, effectively grounding the input to receiver module tty channel 2. The +22 volts also energizes nsk/fsk filter relay K1.
- The +20 volt dc output from the regulator is applied through contacts 6 and 1 of MODE SELECTOR switch S4F to pin 1 of receive audio module connector XA1, A1J1. The +20 volts energizes the bfo generation circuitry. The +20 volts is also applied to a voltage divider containing BFO control R2. The setting of R2 determines the voltage applied through XA1, A1J1-2 to the rc circuit connected to the emitter of BFO A1A3Q1, which in turn determines the frequency of the oscillator.
- Ground is applied through S4A, S4C, S4D, and S4G as follows:
 - Switch S4A grounds receiver module terminal XA4, A4J1-5, which connects tty squelch adjust A4A2R1 to ground through A4A2R30. The value of A4A2R30 is lower than the corresponding resistor used in the nsk modes, modifying the tty squelch circuitry for 850-Hz mode of operation. This is necessary because the wideband width of fsk operation results in a higher noise level than that experienced in nsk operation.
 - Switch S4C grounds the output of 600-ohm voice amplifier A3A2Q8 through contacts 12 and 7, and the output of the transmitter module 50-ohm mike circuitry through contacts 1 and 6.
 - Switch S4D grounds the input to nsk input filter FL4, providing a grounded input to receiver module tty channel 2 (A4J1-15), which is unused in 850-Hz mode.
 - Switch S4G grounds transmitter module pin XA3, A3J1-7. When pin 7 is grounded, mixer oscillator A3A2Q3, Q4 is switched to produce an output of 26,050 Hz through 850-Hz switch A3A2CR5. Diode-by-10 bypass switch A3A2CR10 is biased into conduction through isolation diode A3A2CR12, bypassing the divide-by-10 circuitry to apply the 26,050-Hz from the mixer oscillator direct to mixer A3A2T1. Diode A3A2CR4 is forward biased because of the ground from pin 7 applied through A3A2R26. Output mixer amplifier A3A2Q2 is switched to 2,000-Hz fsk filter FL2 through diode switch A3A2CR4.

1-68. 85-HZ OPERATION

When MODE SELECTOR switch S4 is set at 85 HZ, +22 volts, +20 volts and ground are applied to the appropriate circuit as follows:

The +22 volts from the preregulator is applied through contacts 12 and 8 of MODE SELECTOR switch S4F to pin 17 of receiver module connector XA4, A4J1. The +22 volts forward biases channel 1 switch A4A2Q3, effectively grounding the input to receiver module tty channel 1.

The + 20 volts dc output from the regulator is applied through contacts 6 and 2 of MODE SELECTOR switch S4F to pin 15 of transmitter module connector XA3, A3J1. The + 20 volts energizes divide-by-10 circuit A3A1Q11-Q18. Thus, mark-space tones generated by mark-space oscillators A3A2Q19-Q22 are divided by 80 in 85 Hz operation rather than by 8 as in 850 Hz operation.

Ground is applied through S4A, S4C, and S4G as follows:

- Switch S4A grounds receiver module pin XA4, A4J1-6, which connects tty squelch adjust A4A2R1 to ground through A4A2R31 in all nsk modes. This action compensates for the difference in noise content between fsk signals and band nsk signals caused by the difference in bandwidths.
- Switch S4C grounds the output of 600-ohm voice amplifier A3A2Q8 through contacts 12 and 8, and the output of transmitter module 50 ohm mike circuitry through contacts 2 and 6.
- Switch S4G grounds transmitter module pin XA3, A3J1-8 through contacts 10 and 12. When pin XA3, A3J1-8 is grounded (as it is in all 85 Hz modes), A3A2C1 parallels A3A2C2, narrowing the pass band of sine wave pass filter A3A2C1, C2, L1 for nsk tones.

1-69. VOICE OPERATION

When MODE SELECTOR switch S4 is set at VOICE, +22 volts, +20 volts, and ground are applied to the appropriate circuits as follows:

The +22 volts and +20 volts are not switched to any special circuitry in voice mode.

Ground is applied through S4A, S4D, and S4G as follows:

- Switch S4A grounds receiver module pin XA4, A4J1-23 through contacts 3 and 6, resulting in a mark-hold output from the modem for all associated receive tty equipment.
- Switch S4D grounds the input to nsk input filter FL4 through contacts 6 and 3, providing a grounded input to receiver module tty channel 2 (through XA4, A4J1-15), which is not used in the voice mode.
- Switch S4G grounds the input of transmit module tty amplifier A3A2Q6 through contacts 9 and 12, preventing spurious output of mark-space tty tones from the transmitter module in voice operation. Contacts 3 and 6 provide a ground for relay A5K1 through CR2, preventing interaction with units attached to the modem through pin A of AUXILIARY connector J5.

1-70. 85-HZ DIVERSITY OPERATION

When MODE SELECTOR switch S4 is set at 85 HZ DIVERSITY, + 22 volts, +20 volts, and ground are applied to the appropriate circuits as follows:

The +22 volts from the preregulator is not switched to any special circuitry in the 85-Hz diversity mode.

The +20 volts from the regulator is applied through contacts 6 and 4 of MODE SELECTOR switch S4F to pin 15 of transmitter module connector XA3, A3J1, energizing divide-by-10 circuit A3A1Q11-Q18 for nsk operation.

Ground is applied through S4A, S4C, and S4F as follows:

- Switch S4A grounds receiver module pin XA4, A4J1-6 through contacts 4 and 6, connecting tty squelch adjust A4A2R1 to ground through A4A2R31 in all nsk modes. This action compensates for the difference in noise content between fsk signals and nsk signals caused by the wider fsk bandwidth.
- Switch S4C grounds the output of 600-ohm voice amplifier A3A2Q8 through contacts 12 and 10, and the modem 50-ohm mike output through contacts 4 and 6. This action prevents the modem from introducing noise into the voice input of the associated radio transmitter.
- Switch S4G grounds transmitter module pins XA3, A3J1-5 and 8 through contacts 4, 6 and 10, 12, respectively. When pin 5 is grounded, the output of mixer amplifier A3A2Q2 is applied to the 425-Hz nsk section of FL1 through diode switch A3A2CR3. When pin XA3, A3J1-8 is grounded, A3A2C1 parallels A3A2C2, narrowing the pass band of sine wave pass filter A3A2C1, C2, L1 for nsk tones.

1-71. 85-HZ + VOICE OPERATION

When MODE SELECTOR switch S4 is set at 85 HZ + VOICE, + 22 volts, +20 volts, and ground are applied to the appropriate circuits as follows:

The +22 volts from the preregulator is applied through contacts 12 and 11 of MODE SELECTOR switch S4F to pin 17 of receiver module connector XA4, A4J1. The +22 volts forward biases channel 1 switch A4A2Q3, effectively grounding the input to receiver module tty channel 1.

The +20 volts from the regulator are applied through contacts 6 and 5 of MODE SELECTOR switch S4F to pin 15 of transmitter module connector XA3, A3J1, energizing divide-by-10 circuit A3A1Q11-Q18 for nsk operation.

Ground is applied through S4A, S4B, and S4G as follows:

- Switch S4A grounds receiver module pin XA4, A4J1-6, through contacts 5 and 6, connecting tty squelch adjust A4A2R1 to ground through A4A2R31. This action compensates for the difference in noise content between fsk signals and nsk signals caused by the wider fsk bandwidth.

- Switch S4B switches the keyline to transmitter module pin XA3, A3J1-11. When an attached 50-ohm mike is keyed (by a ground, switched at the mike), keying switch A3A2CR8 is forward biased, permitting the transmitter module 50-ohm mike control circuit to pass signals originated by the microphone.
- Switch S4G grounds transmitter module pin XA3, A3J1-8 through contacts 5 and 6. When pin XA3, A3J1-8 is grounded, A3A2C1 parallels A3A2C2, narrowing the pass band of sine wave pass filter A3A2C1, C2, L1 for nsk tones. Ground is also applied through contacts 12 and 11 to mike return pin E of MICROPHONE jack J3. Pin D of RCVR TRANS AUDIO jack J2 is also connected to ground through contacts 12 and 11. This action grounds the secondary of transmit output transformer A6T1, resulting in an unbalanced output for the 85-Hz + voice mode only.

Section IX. METERING STAGE ANALYSIS AND SWITCHING

1-72. GENERAL

A detailed discussion of the operation of the metering circuitry is given in paragraph 1-71. The following figure shows that the metering circuitry consists of A5A2R19, R11; meter multiplier resistors A5A2R10, R20 and A7R6; meter M1; meter bias board A7; sampler resistors; and METER FUNCTION switch S3.

1-73. METERING CIRCUITRY

METER FUNCTION Switch Set at DC LOOP NO. 1. When a loop current flows in dc loop No. 1, a voltage drop proportional to the current appears across sampler resistor A5A2R19. When METER FUNCTION switch S3 is set at DC LOOP NO. 1, the negative terminal of meter M1 is connected through S3 contacts 7 and 8 to one side of sampler resistor A5A2R19. The positive terminal of M1 is connected through S3 contacts 1 and 2 and meter multiplier resistor A5A2R20 to the other side of sampler resistor A5A2R19. The zero on M1 is at center scale, so the direction of the current through A5A2R19 can be observed by deflection of the meter indicator. Current flow is shown for an internal supply and results in a deflection of M1 to the right. Current flows in the opposite direction in this portion of dc loop No. 1 when supplied from a source external to the modem, resulting in a deflection to the left.

METER FUNCTION Switch Set at DC LOOP NO. 2. In this position of the METER FUNCTION switch, the metering circuitry operates as described above, except that dc loop No. 2 is sampled.

METER FUNCTION Switch Set at DISCRIMINATOR. Received tty tones, converted to tty pulses, are sampled at the output of receiver module A4 through meter multiplier resistor A7R6. The positive terminal of M1 is connected to meter multiplier resistor A7R6 through switch contacts 1 and 4; the negative terminal is connected to pin XA4, A4J1-24 through contacts 7 and 10.

METER FUNCTION Switch Set at REGULATED DC. Voltage divider A7R2, R1 samples the output from the +20 volt regulator. When S3 is set at REGULATED DC, M1 parallels A7R1 through switch contacts 1, 5 and 7, 11.

METER FUNCTION Switch Set at RCV LEVEL. In this setting only, zero on M1 is shifted from center scale to left scale. A positive bias, derived from voltage divider A7R4, R3 is applied to the negative terminal of meter M1 through switch contacts 12 and 7. Tty tones and/or voice from the modem input circuitry is applied to detector A7CR2, CR1, C1, C2. Resistor A7R5 reduces the input to the desired level. The rectified input reduces the level of the bias applied to the negative terminal of M1, causing the meter to indicate upscale for an audio input to the modem. The meter is returned to ground through switch contacts 1 and 6.

TEST METER, SWITCHING

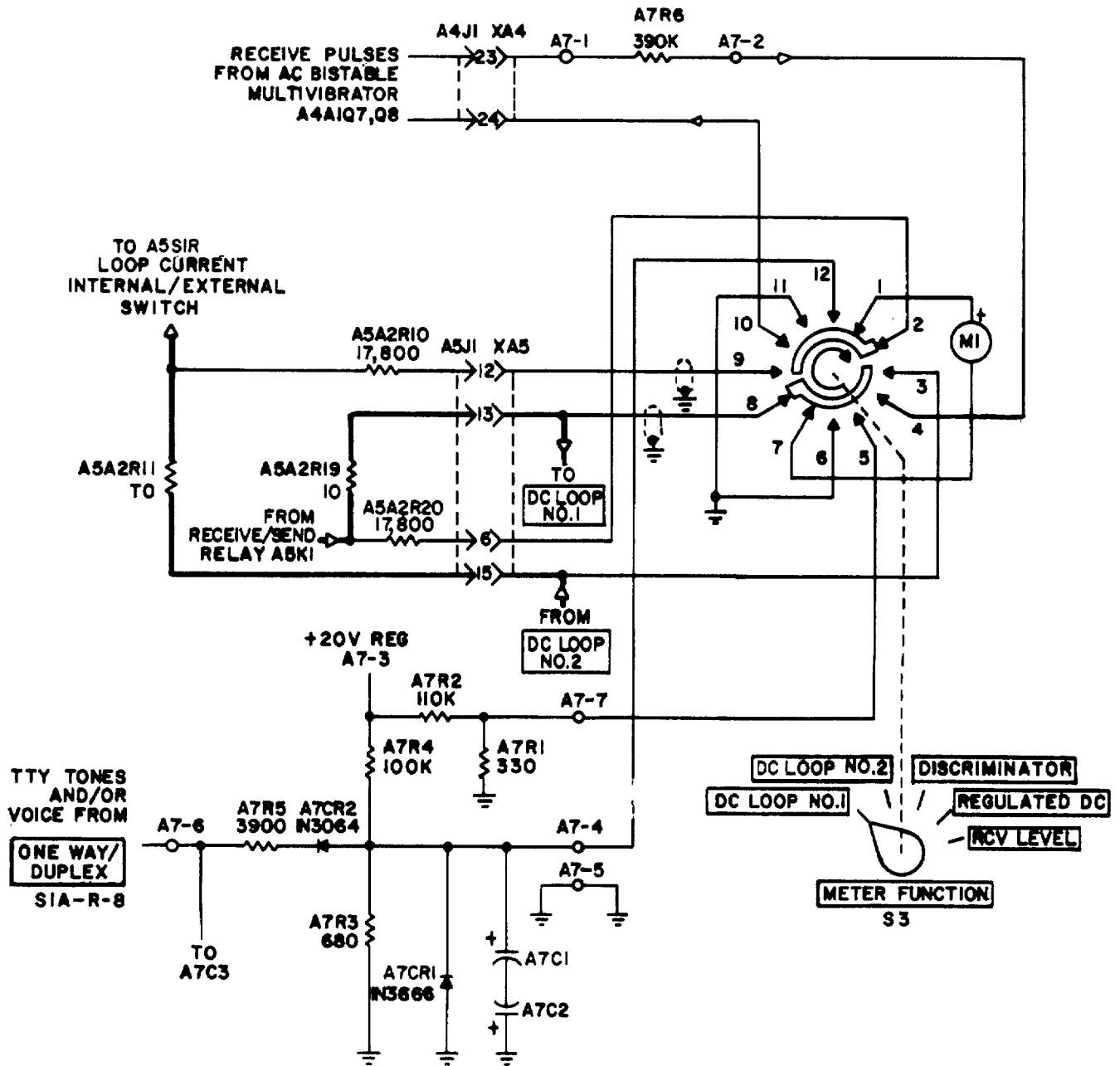

CHAPTER 2

INDEX

SECTION I

GENERAL INFORMATION

	PAGE
General.....	2-1
Repair Parts, Tools, Test Equipment, and Materials.....	2-1

SECTION II

TROUBLESHOOTING

General Information.....	2-4
Modem Bench Test Setup and Test Conditions.....	2-5
Troubleshooting Symptom Index.....	2-7
Troubleshooting Chart.....	2-8
Test Point Measurements.....	2-24

SECTION III

MAINTENANCE PROCEDURES

Removing and Replacing Modules.....	2-27
Removing and Replacing Front Panel Assembly.....	2-28
Removing and Replacing Printed Circuit Boards A6, A7, A8, A9.....	2-29
Removing and Replacing Power Transistors Q1, Q2, Q3.....	2-29
Removing and Replacing Connectors and Chassis Components.....	2-30

SECTION IV

ADJUSTMENT PROCEDURES

General Instructions.....	2-33
Regulated Voltage Adjustment.....	2-34
Loop Current Adjustment.....	2-35
BFO Frequency Limits Adjustment.....	2-37
Scope Module A2 Centering Adjustment.....	2-38
Scope Module A2 Alignment.....	2-39

CHAPTER 2

DIRECT SUPPORT MAINTENANCE

Section I. GENERAL INFORMATION

WARNING

DEATH ON CONTACT may result from contact with high voltage in modem modules. Scope module A2 contains 1,100 volts dc; loop battery module A5 contains 127 volts dc.

2-1. GENERAL

This chapter covers direct support troubleshooting, maintenance, and test procedures for the modem. Section I lists the tools, test equipment, and materials needed to perform direct support maintenance. Troubleshooting and test procedures are described in section II. Maintenance procedures are covered in section III and adjustments in section IV.

2-2. REPAIR PARTS, TOOLS, TEST EQUIPMENT, AND MATERIALS

Repair Parts: Refer to TM 11-5805-387-20P-2, and TM 11-5805-387-34P-2

Special Tools: No special tools are needed.

Tools, Test Equipment, and Materials:

TOOLS

NATIONAL STOCK NUMBER

Tool Kit, Electronic Equipment TK-100/G	5180-00-605-0079
Tool Kit, Electronic Equipment TK-105/G	5180-00-610-8177

TEST EQUIPMENT

Counter, Electronic, Digital Readout AN/USM-207	6625-00-911-6368
Electronic Voltmeter AN/URM-145	6625-00-973-3986
Generator, Signal AN/URM-127	6625-00-783-5965
Handset H-33/PT	5965-00-163-9947
Multimeter ME-26B/U	6625-00-646-9409
Oscilloscope AN/USM-281A	6625-00-228-2201
Power Supply PP-3940/G	6130-00-404-1727
Test Set, Teletypewriter TS-799A/UGM-1	6625-00-965-0195
Voltmeter ME-301U	6625-00-580-5298
Multimeter TS-352B/U	6625-00-553-0142
600 Ohm, 1/2 Watt Test Potentiometer	

MATERIALS

Test Cable No. 1

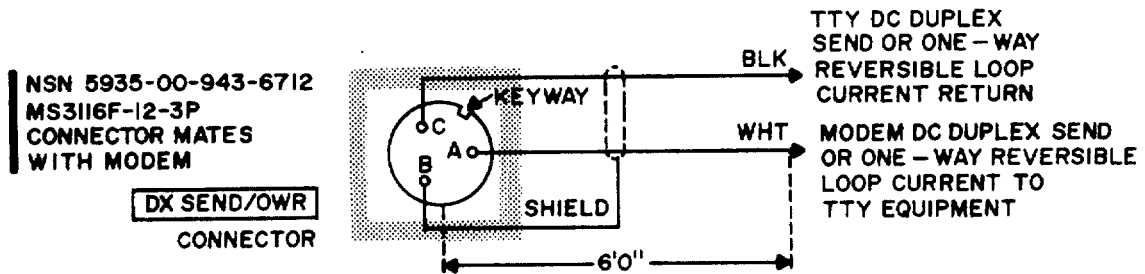

Test Cable No. 2

CX-10071/U

NSN 5995-00-985-7998

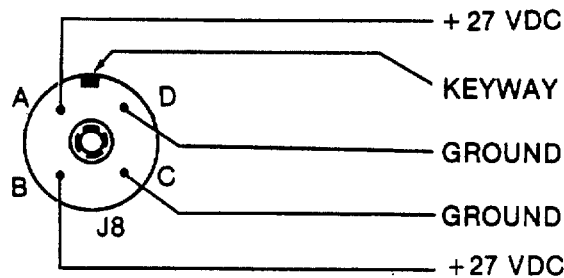

Test Cable No. 3

NSN 5915-00-762-1495
6612
MS3116F12-10S
(FEMALE, VIEWED FROM BACK)

NSN 5935-00-771-2262
6612
MS3116F12-10P
(MALE, VIEWED FROM BACK)

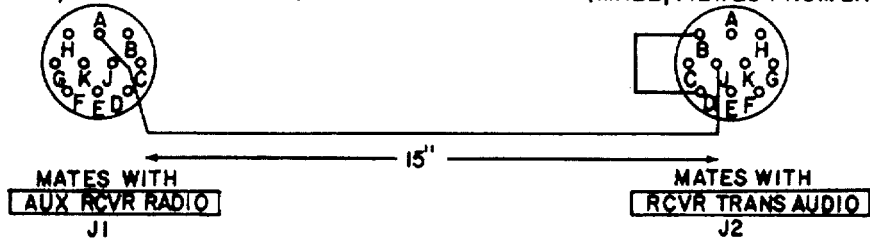

Test cable No. 3 is to be constructed to permit back-to-back operation of the modem for testing. It connects the output of the transmit section of the modem to the input of the receive section.

- Cable: 17-inch length of No. 24 ASW single-conductor stranded cable.
- Connectors: NSN 5935-00-762-1495 J1
NSN 5935-00-771-2262 J2

Connect one end of cable to pin J of connector 6612 MS 3116 F12-10P and the other end to pin A of connector 6612 MS 3116 F12-10S. Connect a one-quarter inch wire between pins B and D of 6612 MS 3116 F12-10P.

OPTIONAL MATERIALS

Extender test cables may be needed to reach operating modem modules. Construct these cables if you need them. Construct at least one 15-pin and one 25-pin test cable.

- Cable: 3-foot lengths of No. 24 ASW shielded single-conductor stranded audio cable.
- Connectors: NSN 5935-00-914-2287 A3J1
NSN 5935-00-930-7025 A1J1
NSN 5935-00-930-7026 XA1
NSN 5935-00-880-2884 XA3

Strip shielding back 1 inch from female connector on both test cables. Connect shields at male end to a heavy bus that can be secured to the modem chassis common ground point.

EXTENDER CABLE

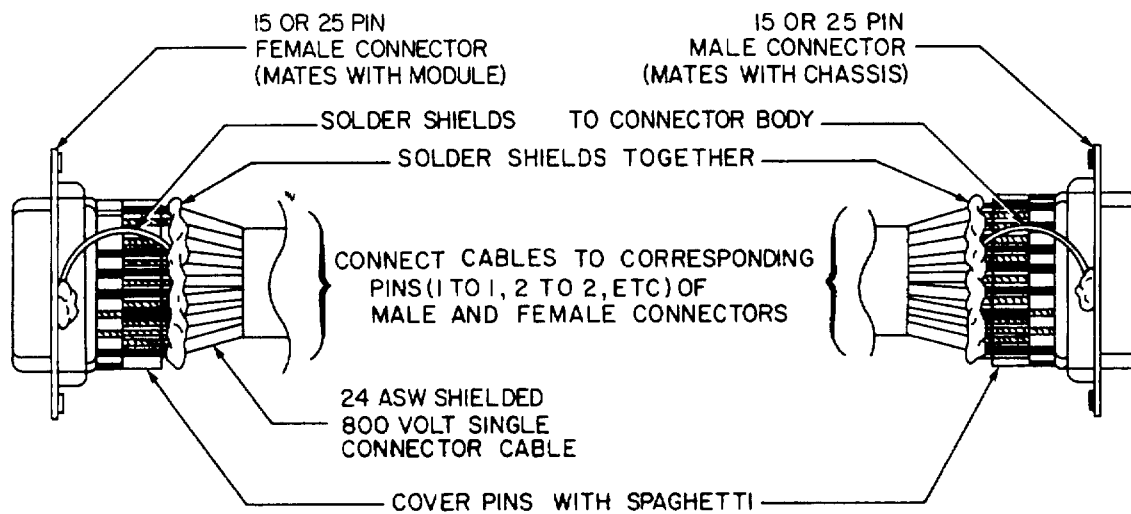

Section II. TROUBLESHOOTING



DEATH ON CONTACT may result from contact with high voltage in modem modules. Scope module A2 contains 1,100 volts dc; loop battery module A5 contains +127 volts dc.

NOTE

This section supplements the troubleshooting procedures found in the modem's operator (TM 11-5805-387-10-2) and organizational maintenance (TM 11-5805-387-20-2) manuals. It also supplements the troubleshooting procedures found in the maintenance manuals for Radio Teletypewriter Sets AN/GRC-142(*) and AN/GRC-122(*) (TM 11-5815-334-12, TM 11-5815-334-35).

2-3. GENERAL INFORMATION

DEFINITION

Troubleshooting has three steps - sectionalization, localization, and isolation.

- Sectionalization means tracing the fault to a module or assembly.
- Localization means tracing the fault to a subassembly within a module or assembly.
- Isolation means pinpointing the specific part or connection causing trouble.

PROCEDURES

SENSE the trouble:

Check meter readings and other visual signs to sectionalize trouble;
Check for dirt, dust, or moisture;
Check for loose screws or nuts.

OPERATE the unit:

An operational test can help pinpoint trouble quickly. See TM 11-5805-387-10-2.

USE the CHART:

The troubleshooting chart lists common symptoms, troubles, and corrective measures. Not all trouble symptoms are listed in the chart, so use it as a guide for analyzing symptoms not listed.

TEST POINT DATA:

Paragraph 2-7.
Use with troubleshooting chart to isolate defective parts.

REMOVING AND REPLACING PARTS:

Refer to section III

ADJUSTING AND ALIGNING MODULES:

Refer to section IV

NOTE

When conducting tests, investigate the possibility of intermittent troubles. Jarring or tapping the equipment may expose this type of problem. Do not try to correct trouble this way. Check the modem's wiring and connections to eliminate trouble caused by loose connections.

2-4. MODEM BENCH TEST SETUP AND TEST CONDITIONS

- Perform all checks in the troubleshooting chart with the equipment connected as shown below.
- Make sure that all the modem's modules are secure in the chassis.
- Read all instructions carefully before starting the tests, so you will understand what is to be accomplished.

POWER CONNECTIONS

Use Power Supply PP-3940/G or an equivalent dc power source for all electrical servicing and test procedures. The power source must supply + 27 volts dc at 2.6 amperes with less than 1 volt root-mean-square (rms) ripple.

TEST EQUIPMENT

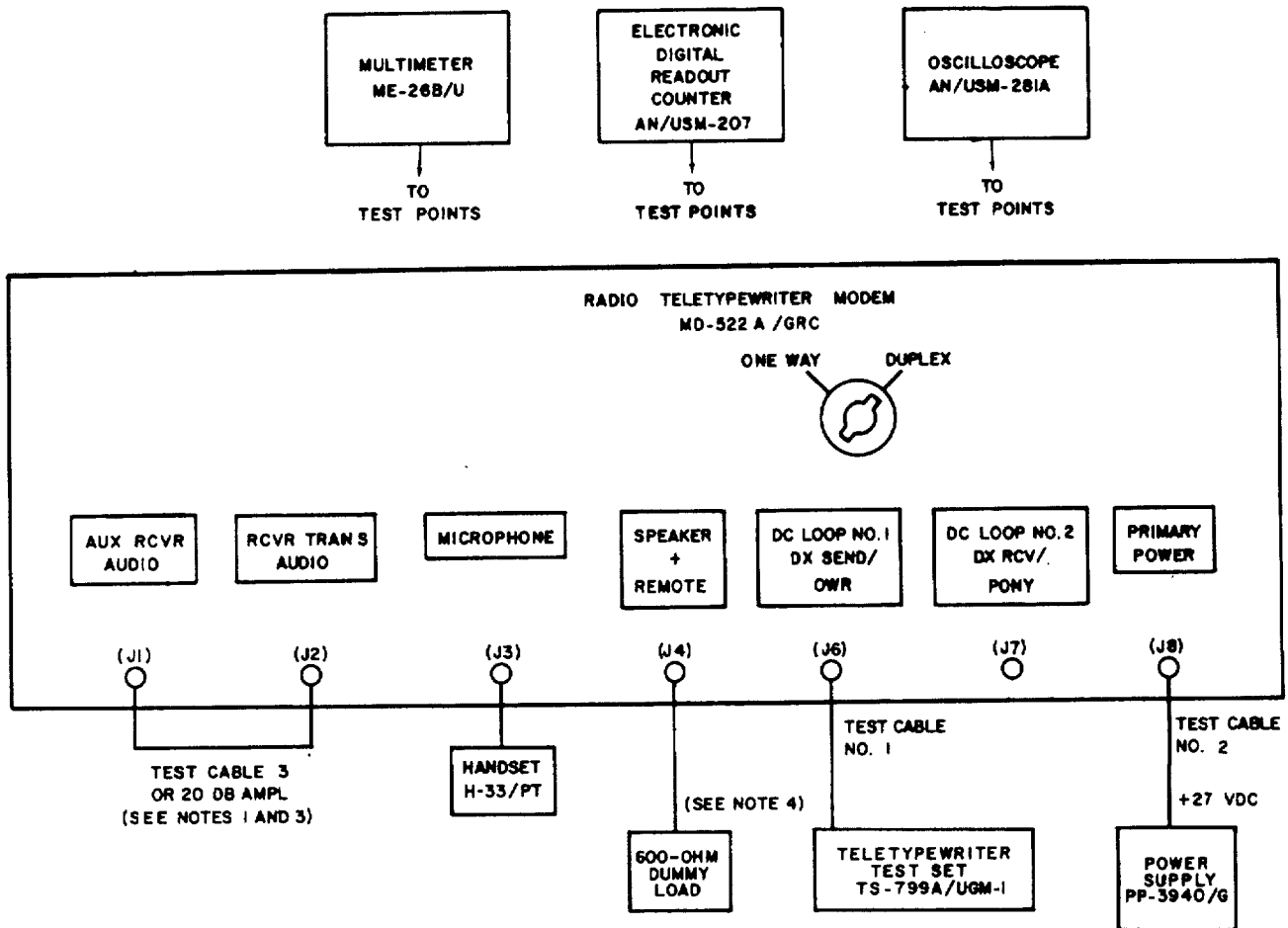

NOTES

1. Set ONE WAY/DUPLEX switch at DUPLEX when test cable No. 3 is used.
2. Use extender cables for access to operational module for internal adjustments.
3. For adjustment of tty squelch adj A4A2R1, the input to AUX RCVR AUDIO J1 must be amplified 20 db. For other A4 module adjustments, amplifier is optional. Amplifier should have following minimum characteristics:

Frequency response flat 100 to 3,500 Hz ± 0.5 db
 Gain 20 db
 Input level 200 mv rms into 600 ohms
 Output level 2.45 v rms Into 600 ohms
 Distortion less than 4%

4. The 600-ohm dummy load must be connected to J4A for 10 mw and to J4-L for 2 watt audio output measurements.

TEST CONDITIONS

- Turn on the test equipment and allow a 5-minute warmup period.
- When checking all transmit modes except VOICE, set the MODE SELECTOR switch to the desired mode of operation, and set the TS-799AIUGM-1 controls as follows:

POWER - 115 V ON
 RATE - 7.5 BAUDS
 DISTORT SELECT - OFF
 CURRENT SELECT - 60
 MESSAGE TRANSMIT - ON
 MESSAGE SELECT - DOT/CY (sets up equipment to produce an output of alternate marks and spaces)
 MESSAGE SELECT - SELECTED PULSES (sets up equipment to produce a continuous selected character as determined by the position of the MARK - SPACE toggle switches)

NOTE

With the AUTO MARK HOLD switch in the OFF position use the same procedures to check the receiving modes; the transmit operation controls both transmitter output and receiver input through test cable No. 3. Warm up the BFO oven for 5 minutes before performing tests or adjustments in the 850-Hz mode. After the warmup period, adjust the BFO control for a symmetrical Lissajous pattern (when keying).

2-5. TROUBLESHOOTING SYMPTOM INDEX

Use this Index to quickly find procedures in the troubleshooting chart.

MODEM	TROUBLESHOOTING SYMPTOM	PROCEDURE NO.	PAGE
	Does not transmit tty	6	2-14
	Does not transmit voice	7	2-15
	Does not transmit voice or tty	5	2-13
	Incorrect scope display (all M1 Indications except DISCRIMINATOR)	15	2-21
	ON/OFF switch continues to trip	1	2-8
	Receive tty malfunction	10	2-17
	Tuning malfunction (MODE SELECTOR switch at 850 Hz)	12	2-19
	MODEM TEST METER		
	Low or high REGULATED DC reading	4	2-12
	No DC LOOP current regulation	14	2-21
	No DISCRIMINATOR reading (RCV LEVEL reading and abnormal scope display)	9	2-17
	No RCV LEVEL reading (receive channel malfunctioning)	8	2-16
	No reading	2	2-9
	No receive DC LOOP current in mark-hold position	11	2-18
	No 60 MA LOOP current (with 20 MA LOOP current)	13	2-20
	No +20 volt dc reading	3	2-11

2-6. TROUBLESHOOTING CHART

The troubleshooting chart lists the common malfunctions which you may find during the operation or maintenance of the modem or its components. You should perform the tests/inspections and corrective actions in the order listed.

Use the troubleshooting chart to localize and isolate trouble. The chart supplements the operational checks, troubleshooting charts, and PMCS tables in TM 11-5805-387-10-2 and TM 11-5805-387-20-2. Also, the chart is designed to be used with the foldouts at the back of this manual.

If operational checks or organizational maintenance have designated a defect, find that malfunction in the symptom index (para 2-5) and go directly to that problem.

The troubleshooting chart is indexed by MALFUNCTION/SYMPTOM, for which PROBABLE CAUSES are listed. Follow the TEST PROCEDURES for which in turn an INDICATION and YES or NO instructions are given.

This manual cannot list all malfunctions that may occur, nor all tests or inspections and corrective actions. If a malfunction is not listed or is not corrected by listed corrective actions, notify your supervisor.

MALFUNCTION/SYMPTOM	PROBABLE CAUSE			
	TEST PROCEDURE	INDICATION	YES	NO
(1) ON-OFF SWITCH (CB1) CONTINUES TO TRIP VOICE OR TTY.		Defective: Power source. Circuit breaker CB1. Circuit board A9.		
CAUTION Do not hold ON/OFF switch at ON.				
1. Check polarity and voltage to PRIMARY POWER connector J8.	Proper polarity and +27 vdc	Go to 2.	Replace defective power source (refer to TM 11-5805-387-10-2).	
 <p>Do all continuity and resistance checks with all power removed.</p>				
2. On the inside of the front panel remove the L-shaped compartment housing (para 2-9), check CB1 continuity with power source removed.	Continuity		Replace defective board A9 (para 2-10).	Replace defective CB1 (para 3-8).

MALFUNCTION/SYMPOM	PROBABLE CAUSE		
TEST PROCEDURE	INDICATION	YES	NO
(2) NO TEST METER OR SCOPE READINGS FOR ANY POSITION OF METER FUNCTION SWITCH.	Defective: Modules A2, A5, A3, A4, A1, Chassis..		
1. Connect ME-26B/U across junction of L1 and C22; remove in order modules A2, A5, A3, A4, A1 (para 2-8 and figures on next page).	+22 vdc	Replace defective module (para 2-8).	Go to 2.

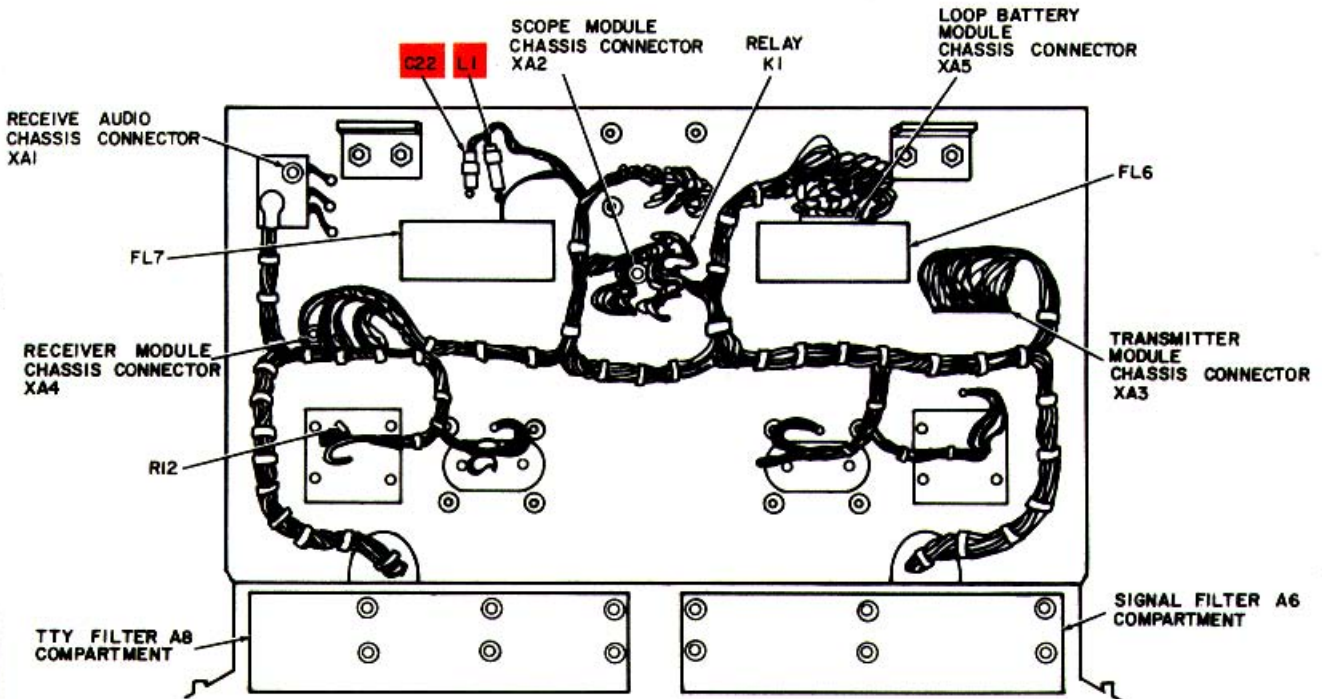

MALFUNCTION/SYMPOM	PROBABLE CAUSE		
TEST PROCEDURE	INDICATION	YES	NO
<p>2. With modules removed, check chassis wiring. Connect ME-26B/U across chassis wiring and ground.</p>	<p>Shorts to ground</p>	<p>Replace chassis.</p>	<p>-----</p>

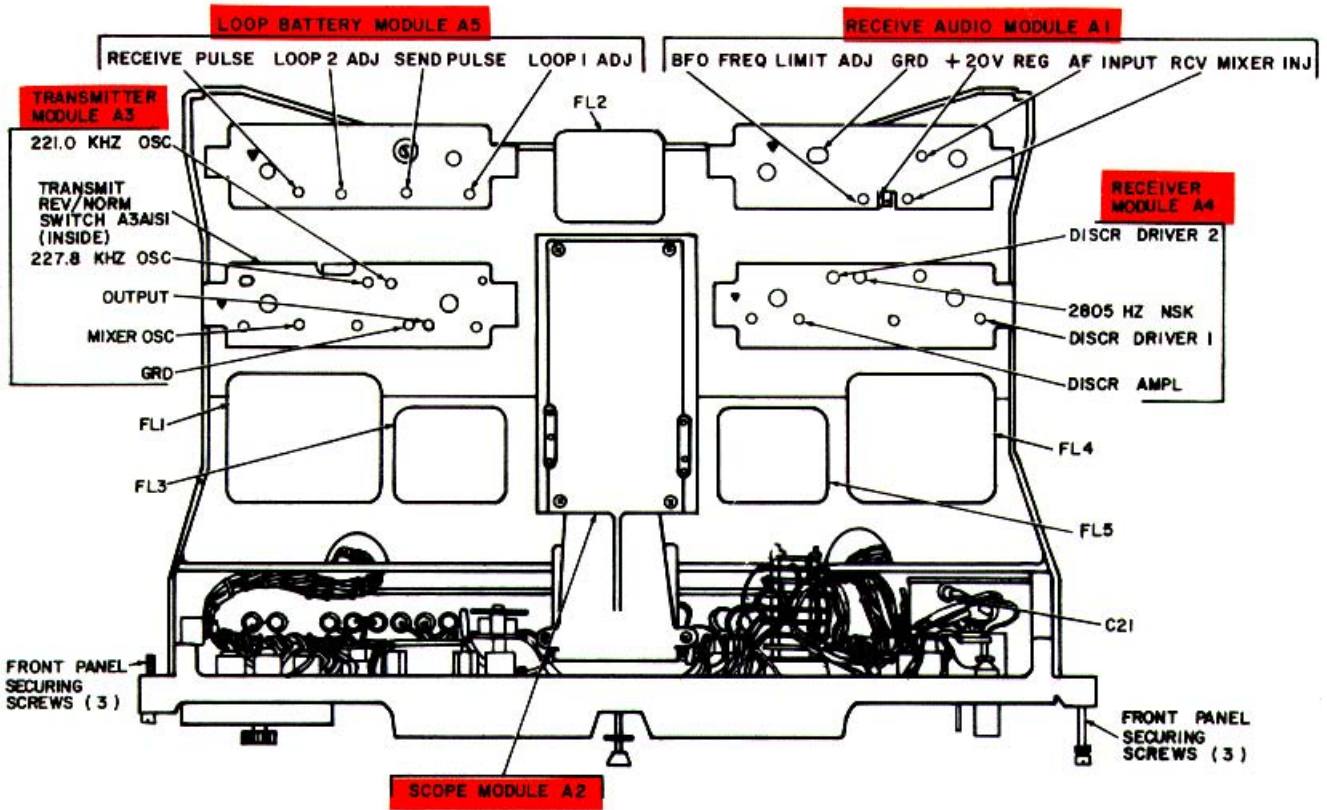

MALFUNCTION/SYMPOM	PROBABLE CAUSE			
	TEST PROCEDURE	INDICATION	YES	NO
(3) NO + 20 VOLTS DC METER INDICATION		Defective: METER M1. Circuit board A7. Meter function switch S3.		
1. Drop front panel down (para 2-9); connect ME-26B/U between meter M1 posts.	+20 vdc	Replace defective meter (para 3-8).	Go to 2.	
2. Set METER FUNCTION switch to RCV LEVEL. Remove cover of circuit board A7 by removing three screws and three washers. Connect ME-26B/U between terminal 3 and terminal 7 of board A7.	+20 vdc	Go to 3.	Replace defective board A7 (para 2-10).	
Do all continuity and resistance checks with all power removed.				
3. Check continuity of METER FUNCTION switch (fig. FO-8).	Continuity	Go to 4.	Replace defective switch S3 (para 3-8).	
4. Connect ME-26B/U across pin 13 of XA1; measure voltage.	+22 vdc	-----	Replace defective wiring.	

MALFUNCTION/SYMP TOM	PROBABLE CAUSE		
	TEST PROCEDURE	INDICATION	YES
(4) METER FUNCTION SWITCH AT REGULATED DC: LOW OR HIGH READING ON TEST METER	Defective: Circuit board A9, Series regulator Transistors Q1, Q2, Q3		
NOTE			
Series regulators Q1, Q2, Q3 automatically cut off when the +22 volt dc output of preregulator board A9 is shorted. Normal operation will resume when short is removed.			
1. Connect ME-26BIU across junction of L1 and C22; measure voltage.	+22 vdc ±1.0	Go to 2.	Replace defective board A9 (para 2-10).
2. Connect ME-26B/U between terminals (E35 and E37) of resistor R8; measure voltage.	+1 to 5 vdc	-----	Go to 3.
3. If voltage less than 1 vdc, check series regulator transistors Q1, Q2, Q3 for shorts.	Short	Replace defective transistor (para 2-11).	Go to 4.
4. If voltage greater than 5 vdc, check series regulator transistors Q1, Q2, Q3 for open condition.	Open	Replace defective transistor (para 2-11).	-----

MALFUNCTION/SYMPOM	PROBABLE CAUSE			
	TEST PROCEDURE	INDICATION	YES	NO
(5) MODEM NOT TRANSMITTING EITHER VOICE OR TTY. 1. With TS-799A/UGM-1 and test cable no. 3 connected (para 2-4) make the following tests across OUTPUT of transmitter module A3 (internal NORM/REV switch at NORM) with the AN/USM-207: MODE SELECTOR switch 850 Hz 85-Hz modes VOICE	Defective: Transmitter module A3. Circuit board A6. RCV-SEND switch S5.			
			Go to 2.	Replace defective module A3 (para 2-8).
	 <p>WARNING</p> <p>Do all continuity and resistance checks with all power removed.</p>			
	2. Connect ME-26B/U between pin 1 of XA3 and terminal 2 of board A6; check for continuity.	Continuity	Go to 3.	Replace defective wiring.
3. Check for continuity between terminals 2 and 13 of board A6; between terminals 14 and 15 of board A6.	Continuity	Go to 4.	Replace defective board A6 (para 2-10).	
4. Set RCV/SEND switch to SEND. Connect ME-26B/U between SEND POST and CENTER POST. Check for continuity. (fig. FO-8)	Continuity	-----	Replace defective switch S5 (para 3-8).	

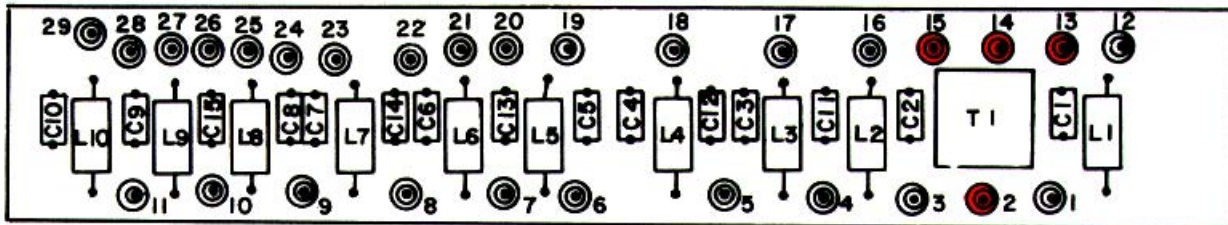

MALFUNCTION/SYMP TOM	PROBABLE CAUSE		
TEST PROCEDURE	INDICATION	YES	NO
(6) MODEM NOT TRANSMITTING TTY.	Defective: Loop battery module A5. Transmitter module A3.		
1. Set METER FUNCTION switch to DC LOOP NO. 1. Check test meter reading during transmission.	Direct current flow in dc loop No. 1.	Go to 2.	Replace defective module A5 (para 2-8).
2. With TS-799A/UGM-1 and test cable no. 3 connected (para 2-4) connect ME-26B/U across SEND PULSE of loop battery module A5.	+0.6 vdc	Go to 3.	Replace defective module A5 (para 2-8).
3. Connect ME-26B/U across terminal 7 of XA5; measure voltage.	+22 vdc	Replace	Go to 4. defective module A5 (para 2-8).
4. Connect ME-26B/U across terminal 11 of XA5; measure voltage.	+20 vdc	Replace defective module A5 (para 2-8).	Go to 5.
5. With TS-799A/UGM-1 and test cable no. 3 connected (para 2-4) make the following tests across test points of transmitter module A3 (internal NORM/REV switch at NORM) with the AN/USM-207:		-----	Replace defective module A3 (para 2-8).
221.0-KHZ OSC	221.0 kHz		
227.8-KHZ OSC	227.8 kHz		
OUTPUT (MODE SELECTOR switch at 850 HZ)	SPACE: 2,425 Hz ± 25 MARK: 1,575 Hz ±25		
OUTPUT (MODE SELECTOR switch at 85 HZ modes)	SPACE: 2,847.5 Hz ± 2 MARK: 2,762.5 Hz ± 2		
OUTPUT (MODE SELECTOR switch at VOICE)	200-2,400 Hz		
MIXER OSC (MODE SELECTOR switch at 850 HZ)	26,050 Hz		
MIXER OSC (MODE SELECTOR switch at 85 HZ DIVERSITY)	23,800 Hz		

MALFUNCTION/SYMPOM	PROBABLE CAUSE		
TEST PROCEDURE	INDICATION	YES	NO
<p>(7) MODEM NOT TRANSMITTING VOICE.</p>	<p>Defective: Mode selector switch S5. Connectors J3, J4, J2. 50-ohm mike keying circuitry. Filter FL3. Transmitter module A3.</p>		
			
<p>Do all continuity and resistance checks with all power removed.</p>			
<p>1. Check continuity of MODE SELECTOR switch wafers S4B, S4C, S4G (fig. FO-8, fig. FO-11).</p>	<p>Continuity</p>	<p>Go to 2.</p>	<p>Replace defective switch S4 (para 3-8).</p>
<p>2. Check continuity of connector J3 (local operation), connectors J4 or J2 (remote operation) (fig. FO-8, fig. FO-11).</p>	<p>Continuity</p>	<p>Go to 3.</p>	<p>Replace defective connector (para 3-8).</p>

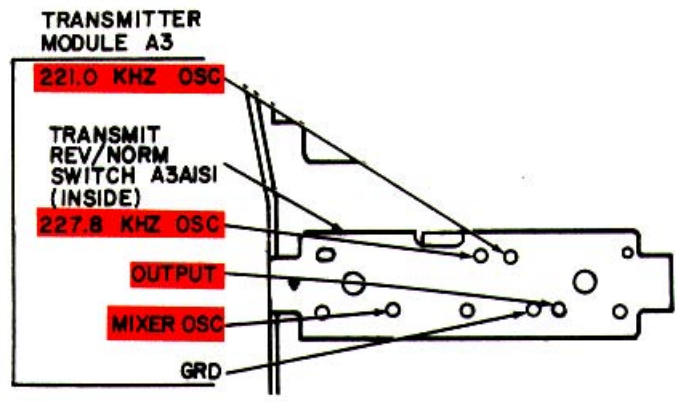

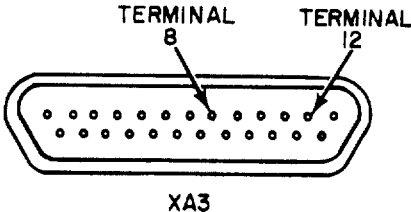
MALFUNCTION/SYMP TOM	PROBABLE CAUSE		
	TEST PROCEDURE	INDICATION	YES
3. Remove transmitter module A3. Check continuity of 50-ohm mike keying circuit components external to module A3: diode CR4, RCV/SEND switch S5, circuit board A6, feed through capacitors C4, C9, C17, C18 (fig. FO-11).	Continuity	Go to 4.	Replace defective component.
4. Connect AN/USM-207 across terminal 1 of filter FL3. Speak into mike. Connect AN/USM-207 across terminal 3 of filter FL3. Speak into mike. FL3 (para 3-9).	200-2,300 Hz 200-2,300 Hz	Continue test -----	Go to 5. Replace defective filter
5. Connect ANIUSM-281 between terminal 8 (ground) of XA3 and terminal 12 of XA3.	Mike Input signal present.	Replace module A3 (para 2-8).	-----
 <p style="text-align: center;">XA3</p>			
(8) NO RCV LEVEL READING ON METER M1. RECEIVE CHANNEL MALFUNCTIONING	Defective: One way-duplex switch S1		
NOTE			
There will be no RCV LEVEL indication when using test cable No. 3.			
Check continuity of ONE WAY/DUPLEX switch (fig. FO-8).	Continuity	-----	Replace defective switch S1 (para 3-8).

MALFUNCTION/SYMP TOM	PROBABLE CAUSE		
TEST PROCEDURE	INDICATION	YES	NO
<p>(9) RCV LEVEL READING ON TEST METER, BUT NO DISCRIMINATOR READING. ABNORMAL SCOPE DISPLAY.</p> <p>Set MODE SELECTOR switch to 850 HZ. Check for signal continuity across terminal 8 or 9 of board A7 (fig. FO-8).</p>	<p>Defective: Circuit board A7.</p> <p>Input signal present</p>	<p>-----</p>	<p>Replace defective board A7 (para 2-10).</p>
<p>(10) RECEIVE TTY MALFUNCTION</p>	<p>Defective: Mode selector switch S4. Filter FL4. Relay K1. Filter FL6. Filter FL7. Recover module A4.</p>		
 <p>WARNING</p>			
<p>Do all continuity and resistance checks with all power removed.</p>			
<p>1. Check continuity of MODE SELECTOR switch wafer S4D (fig. FO-8).</p>	<p>Continuity</p>	<p>Go to 2.</p>	<p>Replace defective switch S4 (para 3-8).</p>
<p>2. Connect TS-799A/UGM-1 (para 2-4) and test cable No. 3.</p> <p>Set MODE SELECTOR switch to 85 HZ DIVERSITY. Check for signal continuity across terminal 2 of filter FL4 (fig. FO-8).</p>	<p>Input signal present on AN/USM-281A</p>	<p>Go to 3.</p>	<p>Replace defective filter FL4 (para 3-9).</p>
<p>3. Check for signal continuity across terminal 4 of filter FL4.</p>	<p>Input signal present on ANIUSM-281A</p>	<p>Go to 4.</p>	<p>Replace defective filter FL4 (para 3-9).</p>

MALFUNCTION/SYMPOM	PROBABLE CAUSE		
	TEST PROCEDURE	INDICATION	YES
4. With receiver module A4 removed (para 2-8), check continuity of relay K1 with MODE SELECTOR switch at positions 850 HZ and 85 HZ (fig. FO-8).	Continuity	Go to 5.	Replace defective relay K1 (para 3-9).
5. Replace module A4, set MODE SELECTOR switch at 85 HZ DIVERSITY. Check for signal continuity across terminal 1 of filter FL6 (fig. FO-8).	Input signal present on ANIUSM-281A	Go to 6.	Replace defective filter FL6 (para 3-9).
6. Set MODE SELECTOR switch at 850 HZ. Check for signal continuity across terminal 3 of filter FL7 (fig. FO-8).	Input signal present on ANIUSM-281A	Replace defective module A4 (para 2-8).	Replace defective filter FL7 (para 3-9).
(11) NO CURRENT IN RECEIVE DC LOOP MODEM IN MARK-HOLD CONDITION.	Defective: Meter function switch S3. Receiver Module A4. Loop battery module A5.		
Do all continuity and resistance checks with all power removed.			
1. Check continuity of METER FUNCTION switch S3 (fig. FO-8).	Continuity	Go to 2.	Replace defective switch S3 (para 3-8).

MALFUNCTION/SYMPTOM	PROBABLE CAUSE		
	TEST PROCEDURE	INDICATION	YES
2. With TS-799A/UGM-1 and test cable No. 3 connected (refer to para 2-4), connect ME-26B/U across RECEIVE PULSE of loop battery module A5.	+8.0 vdc	Replace defective module A5 (para 2-8).	Replace defective module A4 (para 2-8).
<p style="text-align: center;">LOOP BATTERY MODULE A5</p> <p style="text-align: center;">RECEIVE PULSE LOOP 2 ADJ SEND PULSE LOOP 1 ADJ</p>			
(12) TUNING MALFUNCTION IN 850 HZ MODE.	Defective: Resistor R2, R5. Receive audio Module A1.		
1. Measure voltage at wiper of BFO variable resistor R2 (fig. FO-8).	+18 to 20 vdc	Go to 2.	Replace defective R2, R5 (para 3-8).
2. Connect ANtUSM-207 across RCVR MIXER INJ of receive audio module A1.	3,805 to 5,805 Hz	-----	Replace defective module A1 (para 2-8).

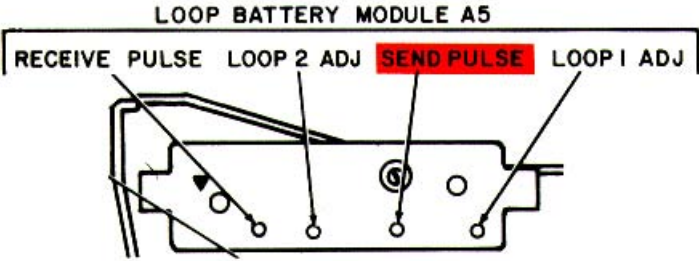
MALFUNCTION/SYMP TOM	PROBABLE CAUSE		
TEST PROCEDURE	INDICATION	YES	NO
(13) 20-MA LOOP CURRENT, BUT NO 60-MA LOOP CURRENT.	Defective: Dc loop no. 1 switch S7. Dc loop no 2 Switch S8. Loop battery module A5.		
 <p>WARNING</p> <p>Do all continuity and resistance checks with all power removed.</p>			
1. Check continuity of DC LOOP NO. 1 switch (fig. FO-8).	Continuity	Go to 2.	Replace defective switch S7 (para 3-8).
2. Check continuity of DC LOOP NO. 2 switch (fig. FO-8).	Continuity	Go to 3.	Replace defective switch S8 (para 3-8).
3. With TS-799A/UGM-1 and test cable No. 3 connected (para 2-4), connect ME-26B/U across RECEIVE PULSE of loop battery module A5.	+8.0 vdc	Go to 4.	Replace defective module A5 (para 2-8).
4. Connect ME-26BIU across SEND PULSE of loop battery module A5.	+0.6 vdc	-----	Replace defective module A5 (para 2-8).
 <p>LOOP BATTERY MODULE A5</p> <p>RECEIVE PULSE LOOP 2 ADJ SEND PULSE LOOP 1 ADJ</p>			

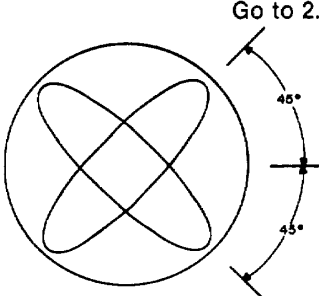
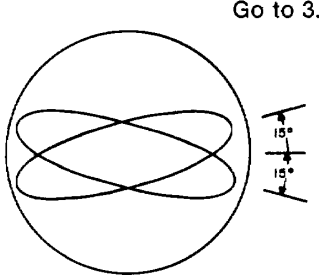
MALFUNCTION/SYMP TOM	PROBABLE CAUSE			
	TEST PROCEDURE	INDICATION	YES	NO
(14) LOSS OF DC LOOP CURRENT REGULATION.	Defective: Loop battery module A5.			
	1. With TS-799A/UGM-1 and test cable No. 3 connected (para 2-4), connect ME-26B/U across RECEIVE PULSE of loop battery module A5.	+8.0 vdc	Go to 2.	Replace defective module A5 (para 2-8).
2. Connect ME-26B/U across SEND PULSE of loop battery module A5.	+0.6 vdc	-----	Replace defective module A5 (para 2-8).	
(15) ABNORMAL SCOPE PRESENTATION BUT NORMAL DISCRIMINATOR INDICATION ON TEST METER.	Defective: Scope module A2. Receiver module A4. Resistor R3.			
	1. Connect the TS-799A/UGM-1 with the MESSAGE TRANSMIT switch set to ON (para 2-4). Connect test cable No. 3 (para 2-4) and set the modem ONE WAY/DUPLEX switch to DUPLEX. Set the MODE SELECTOR switch to 850 HZ and observe the modem CRT.			Replace defective module A2 (para 2-8).
2. Set the MODE SELECTOR switch to 85 HZ and observe the modem CRT.			Replace defective module A2 (para 2-8).	

MALFUNCTION/SYMP TOM	PROBABLE CAUSE			
	TEST PROCEDURE	INDICATION	YES	NO
3. Connect TS-799A/UGM-1 and test cable No. 3 (para 2-4). Make the following tests across test points of receiver module A4 with the AN/USM-207:			Go to 4.	Replace defective module A4 (para 2-8).
DISCR DRIVER 1 (MODE SELECTOR switch at 850 HZ)	Space: 2,380 Hz Mark: 3,230 Hz			
DISCR DRIVER 1 (MODE SELECTOR switch at 85 HZ DIVERSITY)	Space: 2,847.5 Hz ±2 Mark: 2,762.5 Hz ±2			
DISCR DRIVER 2 (MODE SELECTOR switch at 85 HZ or 85 HZ DIVERSITY)	Space: 2,847.5 Hz ±2 Mark: 2,762.5 Hz ±2			
2,805 HZ NSK (MODE SELECTOR switch at 85 HZ, 85 HZ DIVERSITY, or 85 HZ + VOICE)	Space: 2,847.5 Hz ±2 Mark: 2,762.5 Hz ±2			
DISCR AMPL (take reading between J3 and ground)	Space: J3 higher voltage than J2			
DISCR AMPL (take reading between J2 and ground)	Mark: J2 higher voltage than J3			

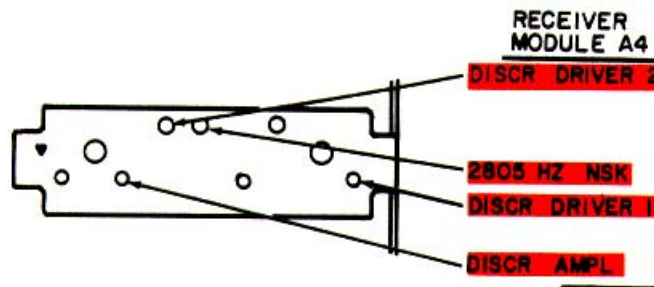

MALFUNCTION/SYMPOM	PROBABLE CAUSE		
TEST PROCEDURE	INDICATION	YES	NO



DEATH ON CONTACT may result from contact with the terminals of R3. With module A2 operating, -800 volts dc appears on scope intensity control resistor R3. Do the following continuity check with all power removed.

4. Remove scope module A2 (para 2-8). Check continuity of variable resistor R3 (fig. FO-8).	Continuity.	-----	Replace defective Resistor R3 (para 3-8).
---	-------------	-------	---

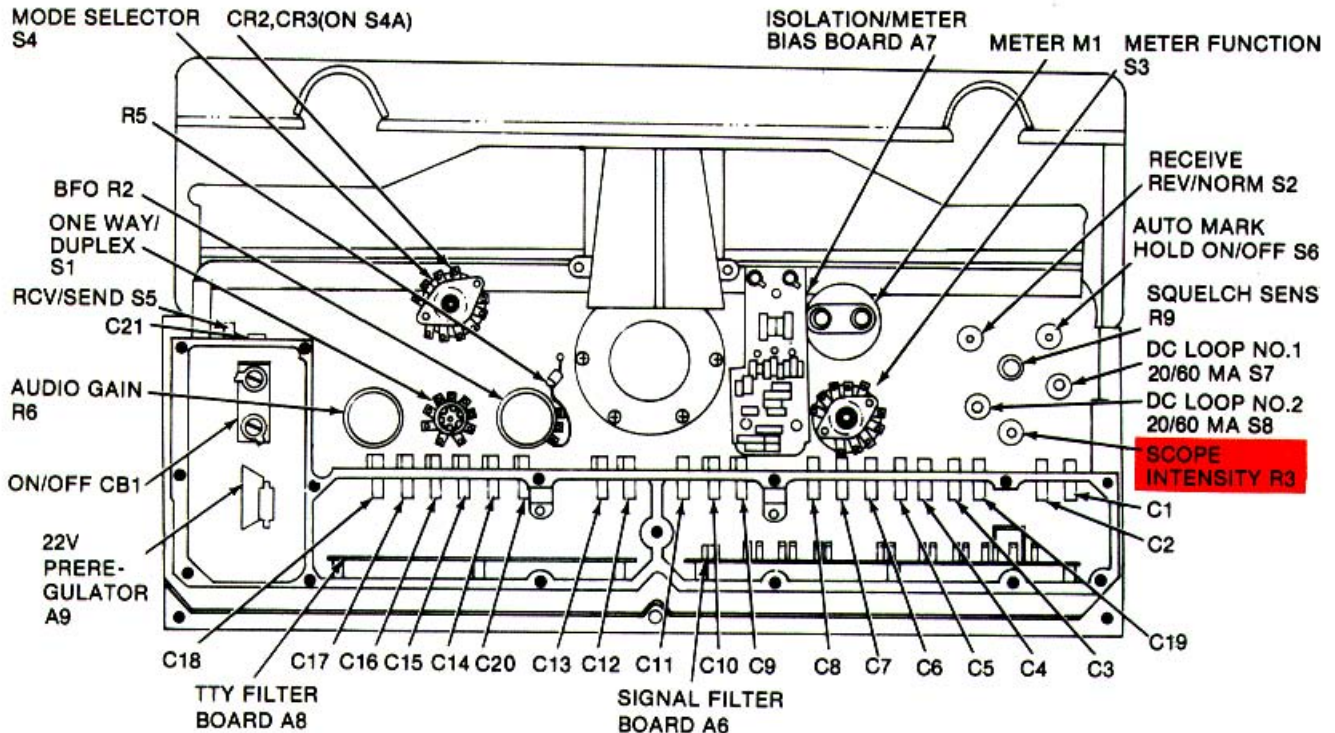

2-7. TEST POINT MEASUREMENTS

CAUTION

Do not short the test point Jacks to the modem chassis. This could cause equipment damage.

- The values listed in test point chart 1 are for troubleshooting purposes only; they represent average values measured at module test points.
- Test equipment: See paragraph 2-2.
- Bench setup and test conditions: See paragraph 2-4.
- Test point locating: Illustrated below
- Remove module covers (para 2-8)

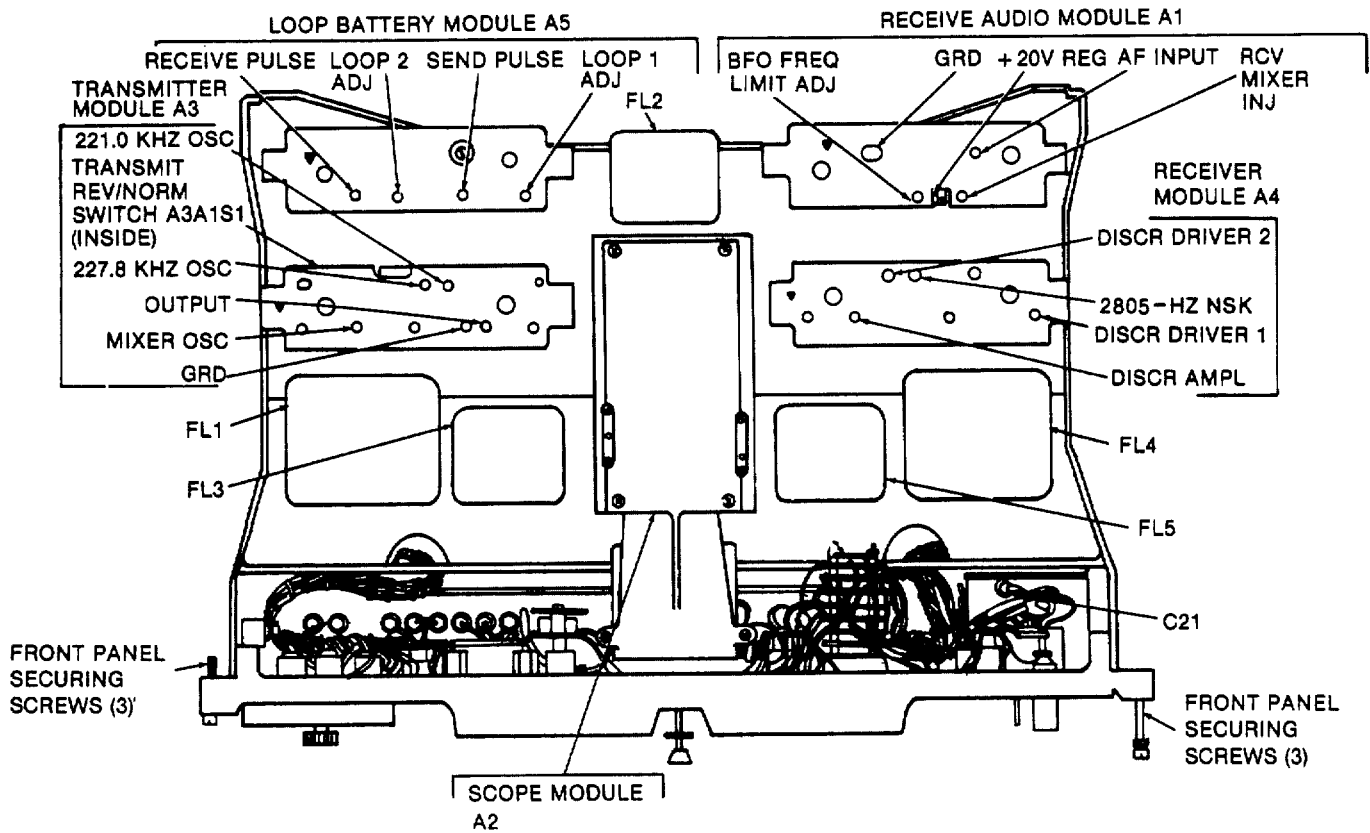

TEST POINT CHART 1

MODULE UNDER TEST

TEST EQUIPMENT

TEST POINT	MODEM SWITCH SETTING	INDICATION
1 RECEIVE AUDIO MODULE A1	AN/URM-145 OR ME-26B/U, AB/USM-207	
1. AF INPUT- A1J1	VOICE or 85 HZ + VOICE	1,000 Hz
2. RCVR MIXER INJ - A2J2	850 HZ	3,805 Hz - 5,805 Hz, varied by BFO control
	85 HZ DIVERSITY	2,380 Hz \pm 2Hz
3. +20V REG - A2J1	Any setting	+20 volts dc \pm 2VDC
2 SCOPE MODULE A2	TS-799A/UGM-1	

NOTE

Test cable No. 3 must be connected and MESSAGE TRANSMIT SWITCH of TS-799A/UGM-1 must be ON. Key microphone to obtain waveshapes shown below.

No test point, observe modem CRT

MODE SELECTOR switch: 850 HZ
ONE WAY/DUPLEX switch: DUPLEX

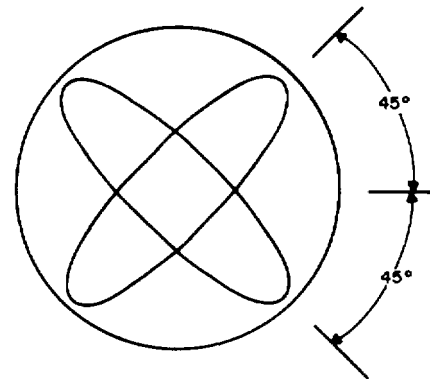

MODE SELECTOR switch: 85 HZ

ONE WAY/DUPLEX switch: DUPLEX

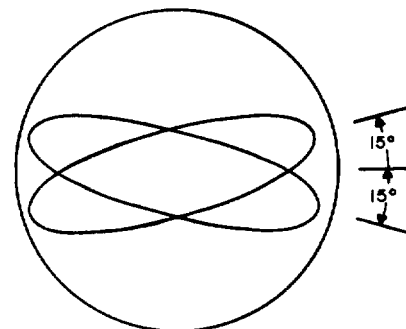

MODULE UNDER TEST		TEST EQUIPMENT	
TEST POINT	MODEM SWITCH SETTING	INDICATION	
3 TRANSMITTER MODULE A3			
	TS-799A/UGM-1, AN/USM-207 Transmitter-internal NORM/ REV switch at NORM		
1. 221.0-KHz OSC - A1J1	Any setting		221.0 kHz \pm 2Hz
2. 227.8-KHz OSC- A1J1	Any setting		227.8 kHz \pm 2Hz
3. OUTPUT	850 HZ		Space: 2,425 Hz \pm 25 Mark: 1,575 Hz \pm 25
	85 HZ or 85 HZ DIVERSITY		Space: 2,847.5 Hz \pm 2 Mark: 2,762.5 Hz \pm 2
	85 HZ \pm VOICE		Space: 2,847.5 Hz \pm 2 Mark: 2,762.5 Hz \pm 2
4. MIXER OSC - A2J3	VOICE 850 HZ 85 HZ DIVERSITY		200-2,400 Hz 26,050 Hz 23,800 Hz
4 RECEIVER MODULE A4			
	TS-799A/UGM-1, AN/USM, ME-26B/U		
1. DISCR DRIVER 1-A1J1	850 HZ		Space: 2,380 Hz \pm 2Hz Mark: 3,230 Hz \pm 2Hz
	85 HZ DIVERSITY		Space: 2,847.5 Hz \pm 2 Mark: 2,762.5 Hz \pm 2
2. DISCR DRIVER 2 - A2J2	85 HZ, 85-HZ DIVERSITY		Space: 2,847.5 Hz \pm 2 Mark: 2,762.5 Hz \pm 2
3. 2805-HZ NSK- A2J1	85 HZ, 85 HZ DIVERSITY, 85 HZ + VOICE		Space: 2,847.5 Hz \pm 2 Mark: 2,762.5 Hz \pm 2
4. DISCR AMPL- A1J2	Any setting A1J3		Space: (Take reading between J3 and ground; J2 and ground) J3 voltage higher than J2 Mark: J2 voltage higher than J3
5 LOOP BATTERY MODULE A5			
	ME-26B/U, TS-799A/UGM-1		
1. SEND PULSE	Any setting		0.6 volts min
2. RECEIVE PULSE	Any setting		8.0 volts min

Section III. MAINTENANCE PROCEDURES

2-8. REMOVING AND REPLACING MODULES



DEATH ON CONTACT may result from contact with high voltage in modem modules. Scope module A2 contains 1,100 volts dc; loop battery in module A5 contains 127 volts dc. Set ON/OFF switch on the front panel to OFF before attempting any removal procedures.

CAUTION

Be careful during removal and replacement. You can prevent accidental damage to other parts, and can prevent potential short circuits caused by dropped hardware. When removing and replacing a part, check carefully for loose hardware or insecure electrical connections. Do not operate the equipment until you make these checks.

NOTE

The procedures below are for modules A1, A2, A3, A4 and A5. The procedure for scope module A2 is listed separately in this paragraph.

REMOVING MODEM CHASSIS FROM CASE

- Loosen six captive screws around outside edge of front panel.
- Grasp ribbed frame around outside edge of front panel.
- Carefully pull modem chassis out of the case.

RECEIVE AUDIO, TRANSMITTER, RECEIVER, LOOP BATTERY MODULES

REMOVE

- Remove modem chassis from case.
- Loosen the four captive screws holding module to chassis.
- Pull up on bail handles to unplug module from chassis connector.
- Lift out module.
- To remove module dust cover, turn bail handles approximately 900 counterclockwise until they release.
- Lift off cover.

REPLACE

- Replace dust cover: Place cover over module; press down bail handles and turn approximately 900 clockwise until they lock in place.
- Plug new module into chassis connector.
- Tighten the four captive screws to secure module to the chassis.
- Replace modem chassis in case.



DEATH ON CONTACT may result from contact with high voltage in scope module A2. Scope module contains 1,100 volts dc.

CAUTION
USE CAUTION WHEN EXPOSING OR HANDLING THE CRT

Breakage of the cathode-ray tube (CRT) causes a high velocity scattering of glass fragments (implosion). To prevent CRT implosion, avoid rough handling or jarring of the instruments. Handling of the CRT shall be done only by qualified maintenance personnel using approved safety masks and gloves.

REMOVE

- Loosen the four captive screws holding module to chassis.
- Lift out module.

REPLACE

- Plug new module into chassis connector.
- Tighten the four captive screws to secure module to chassis.

2-9. REMOVING AND REPLACING FRONT PANEL ASSEMBLY

The modem's front panel cannot be removed completely, but it can be swung away from the chassis to allow access to the components inside.

REMOVE

- Remove the lower six screws holding front panel assembly to the right and left sides of the chassis.

NOTE

Do not remove the top shoulder screws. They serve as hinges.

- Grasp the sides of the front panel near the bottom edge and pull the panel upward until it is parallel to the chassis.
- Turn the chassis and front panel bottom side up.
- Remove the screws holding the cover of the L-shaped compartment housing along the bottom edge of the front panel. (This provides access to the printed circuit boards.)

REPLACE

- Screw on cover of the L-shaped compartment housing.
- Turn the chassis and front panel top side up.
- Grasp the sides of the front panel and push the panel downward until it is perpendicular to the chassis.
- Secure the front panel to the right and left sides of the chassis with six screws.

2-10. REMOVING AND REPLACING PRINTED CIRCUIT BOARDS A6, A7, A8, A9**NOTE**

When board A6 must be removed, unsolder diodes CR1 and CR4 connections at board terminal 5 in addition to the procedures below.

REMOVE

- Detach and swing front panel away from chassis (para 2-9). Remove compartment cover.
- Remove six screws holding circuit board A6 and circuit board A8 to compartment housing.
- Remove three screws holding circuit board A9 to compartment housing.
- Remove three screws holding cover on circuit board A7 and then remove three hex nuts holding circuit board A7 to compartment housing.
- Lift printed circuit board out of compartment to gain access to all terminals on the board.
- Tag and unsolder all wires connected to board terminals.
- Remove board.

REPLACE

- Solder all wires to the terminals of the replacement board. Be sure to connect each wire to the proper terminal. For board A6, be sure to connect diodes CR1 and CR4 to terminal 5.
- Carefully insert board into it's compartment. Be sure that all wires are out of the way.
- Replace screws (or hex nuts for board A7) to secure board to compartment housing.
- Replace screws to secure cover to board A7.
- Reattach front panel to chassis (para 2-9)

2-11. REMOVING AND REPLACING POWER TRANSISTORS Q1, Q2, Q3**REMOVE**

- Detach and swing front panel away from chassis (para 2-9). Remove compartment cover.
- Tag, unsolder and remove all wires from transistor.
- Remove nuts, lockwashers, nylon bushing, screws holding transistor to compartment housing.
- Remove transistor.

NOTE

Do not remove mica insulator unless it is damaged.

REPLACE

- Replace mica insulator if it is damaged. Apply a coat of Grease, Laboratory Stock (NSN 9150-00-598-7445) on mounting surface area before placing mica insulator in position.
- Position transistor on compartment housing.
- Replace screws, nylon bushing, lockwasher, nuts.
- Solder wires to transistor terminals.
- Reattach front panel to chassis (para 2-9).

2-12. REMOVING AND REPLACING CONNECTORS AND CHASSIS COMPONENTS

- To gain access to chassis components, remove modem from chassis.
- Stand modem on end for access to top and bottom of chassis.

CONNECTORS J1, J2, J3, J4**REMOVE**

- Remove printed circuit board A6 from compartment housing (para 2-10).
- Remove hex nut (connectors J1, J2) or spanner nut (J3, J4) holding connector to front panel.
- Carefully push connector out from inside the panel.
- Connectors J3, J4: Tag, unsolder, and remove wires from connector.
- Remove connector.
- Connectors J1, J2: Unscrew rubber bushing retainer ring. Push the bushing back against wires, away from connector, to expose solder terminals. Tag, unsolder, and remove wires from connector; remove connector.

REPLACE

- Solder wires to new connector.
- Connectors J1 and J2: Replace screws on rubber bushing retainer ring.
- Carefully push connector into front panel.
- Replace hex nut (J1, J2) or spanner nut (J3, J4).
- Replace printed circuit board A6 (para 2-10).

CONNECTORS J5, J6, J7, J8**REMOVE**

- Remove printed circuit board A8 from compartment housing (para 2-10).
- Remove hex nut or spanner nut (J8) holding connector to front panel.
- Carefully push connector out from inside of panel.
- Unscrew rubber bushing retainer ring. Push the bushing back against wires, away from connector, to expose solder terminals.
- Tag, unsolder, and remove wires from connector; remove connector.

REPLACE

- Solder wires to new connector.
- Replace screws on rubber bushing retainer ring.
- Carefully push connector into front panel.
- Replace nut.
- Replace printed circuit board A8 (para 2-10).

MODEM SWITCHES

The procedures in this section are for these switches:

- | | |
|---------------------|--------------------------|
| • S1 ONE WAY/DUPLEX | • S6 AUTO MARX HOLD |
| • S2 RECEIVE | • S7 DC LOOP NO.1 REMOVE |
| • S3 METER FUNCTION | • S8 DC LOOP NO.2 |
| • S4 MODE SELECTOR | |
| • S5 RCV/SEND | |

REMOVE

- Tag, unsolder, and remove all wires connected to switch terminals.
- On front panel remove control knob retainer screw or hex nut.
- On inside of front panel remove any hex nuts.
- Remove switch.

REPLACE**CAUTION**

Wafer switch terminals are easily bent and broken. When installing a new switch containing wafers, carefully position wiring harness to prevent strain on switch terminals.

- Place new switch in position.
- On front panel, replace control knob retainer screw or hex nut.
- On inside of front panel replace any hex nuts.
- Solder wires to new switch.
- Position transistor on compartment housing.
- Replace screws, nylon bushing, lockwasher, nuts.
- Solder wires to transistor terminals.

DIODES CR1 - CR4, CR6**REMOVE**

- Tag, unsolder, and remove leads from diode.
- Remove diode.

REPLACE

- Put new diode in place.
- Solder leads to new diode.

VARIABLE RESISTORS

This procedure is for the following resistors:

R1 AUDIO GAIN
R2 BFO
R3 SCOPE INTENSITY
R4 SQUELCH SENS

REMOVE

- Tag, unsolder, and remove leads from resistor.
- Remove control knob retainer screws.
- Remove resistor.

REPLACE

- Put new resistor in place.
- Replace control knob retainer screws.
- Solder leads to new resistor.

FILTERS FL1, FL2, FL3, FL4, FL5**REMOVE**

- On the bottom side of the chassis, remove four hex nuts holding filter to chassis.
- Tag, unsolder and remove leads from terminals.
- Lift out filter.

REPLACE

- Place new filter into position.
- Tighten the four hex nuts.
- Solder leads to terminals.

FILTERS FL6, FL7

REMOVE

- On the top side of the chassis remove hex nuts holding filter to chassis.
- Tag, unsolder and remove leads from terminals.
- Lift out filter.

REPLACE

- Place new filter into position.
- Tighten the two hex nuts.
- Solder leads to terminals.

CIRCUIT BREAKER CB1

REMOVE

- Remove hex nut on front panel ON/OFF switch.
- Tag, unsolder and remove wires from circuit breaker terminals.
- Remove circuit breaker.

REPLACE

- Place new circuit breaker into position.
- Tighten hex nut on front panel.
- Solder wires to circuit breaker terminals.

RELAY K1

REMOVE

- Tag, unsolder and remove all wires from relay.
- Remove two captive screws holding relay to compartment housing.
- Remove relay.

REPLACE

- Position relay on compartment housing.
- Replace captive screws.
- Solder wires to relay terminals.

Section IV. ADJUSTMENT PROCEDURES

2-13. GENERAL INSTRUCTIONS

- Make adjustments after performing maintenance. These tests determine if the modem has been properly repaired and can be returned to use. Adjustments are necessary after replacing modules A1, A2, A5, and board A9. The chart below lists the specific adjustments for each.

ASSEMBLY REPLACED	ADJUSTMENT PROCEDURE	PARAGRAPH
Receive audio module A1	Regulated voltage adjustment; BFO frequency limits adjustment	2-14 2-16
Scope module A2	Centering; Alignment	2-17 2-18
Loop battery module A5	Loop current adjustment	2-15
Preregulator board A9	Regulated voltage adjustment	2-14

- Tools and test equipment: See paragraph 2-2.
- Bench test setup: See paragraph 2-4 for test equipment setup.
- Modem settings: Before starting each adjustment procedure, preset the modem's front panel controls and switches this way:

CONTROL OR SWITCH	SETTING
AUTO MARK HOLD	OFF
RECEIVE	NORM
DC LOOP NO. 1	60
DC LOOP NO. 2	60
SQUELCH SENS	MIDRANGE
SCOPE INTENSITY	MIDRANGE
METER FUNCTION	REGULATED DC
MODE SELECTOR	850 HZ
RCV/SEND	SEND
BFO	MIDRANGE
ONE WAY/DUPLEX	DUPLEX
AUDIO GAIN	MIDRANGE
ON/OFF	OFF

- Internal switches:
 - Set A3S1 NORM/REV switch to NORM.
 - Set A5S1 INT-EXT switch to LOOP 1 and 2-INT.

-
- Adjustment precautions: Observe the following precautions when making adjustments.
- Before making adjustments, make sure that the front panel meter reads + 20 VDC, indicating proper regulated voltage.
- Before starting a procedure, carefully read all steps to become familiar with them.
- Use insulated test probes, or wrap test probes in insulated tape. Use a nonmetallic screwdriver. This will prevent signals to the module cover from being accidentally shorted.
- During adjustment, do not disconnect test equipment until instructed to do so.
- Do not use adjustment procedures as a substitute for troubleshooting.
- Make adjustments only if the value being measured is outside the given tolerance.

2-14. REGULATED VOLTAGE ADJUSTMENT

Test Equipment

Multimeter ME-26B/U

Test Connections

- Connect multimeter's positive probe to capacitor C21.
- Connect ground probe to ground.
- Remove dust cover from receive audio module A1.

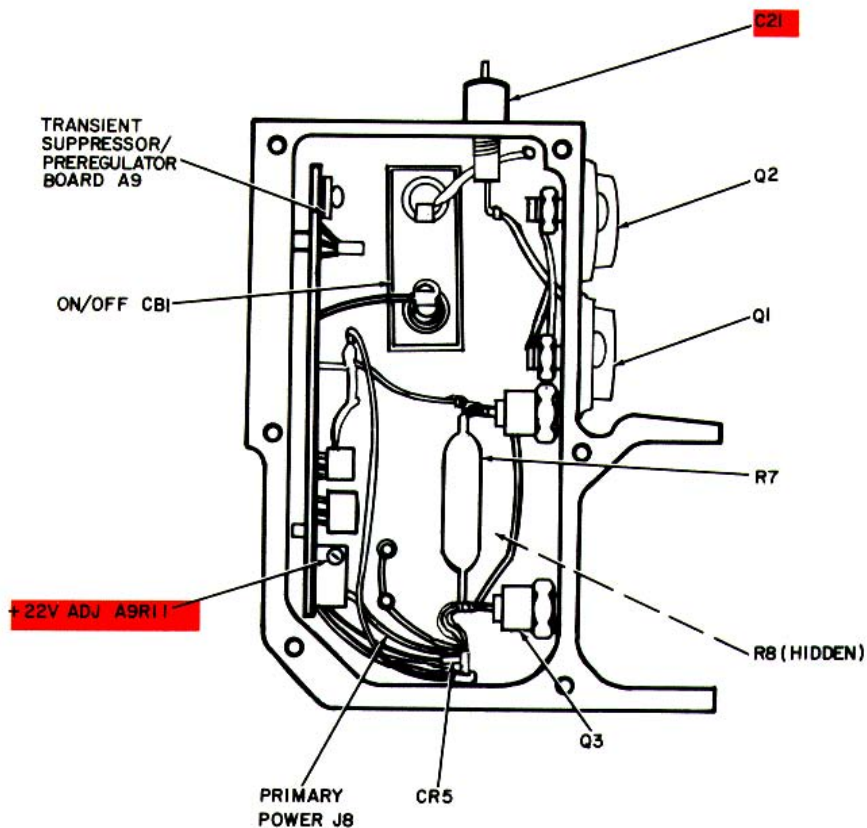

PROCEDURE

INDICATION

NO

- | | | |
|---|--|----------------------------------|
| <ol style="list-style-type: none"> 1. Set power ON/OFF switch to ON. 2. Adjust +22 V ADJ potentiometer A9R11 until multimeter reading is correct. 3. Connect multimeter's positive probe to +20V REG test point on module A1. 4. Adjust +20 V REG ADJ potentiometer A1A2R4 until meter reads 20 vdc \pm 0.1 5. Set ON/OFF switch to OFF. Disconnect test setup. | <p>+ 22 volts dc \pm 0.2</p>
<p>+ 20 volts dc \pm 0.1</p> | <p>Go to 2</p>
<p>Go to 4</p> |
|---|--|----------------------------------|

2-15. LOOP CURRENT ADJUSTMENT

Test Equipment

Multimeter TS-352B/U (set up for current measurement)

Test Connections

-
- Connect multimeter's positive lead to pin A of DC LOOP NO. 1 DX SENDIOWR connector J6. Connect ground lead to pin C of connector J6.
- Remove dust cover from loop battery module A5.

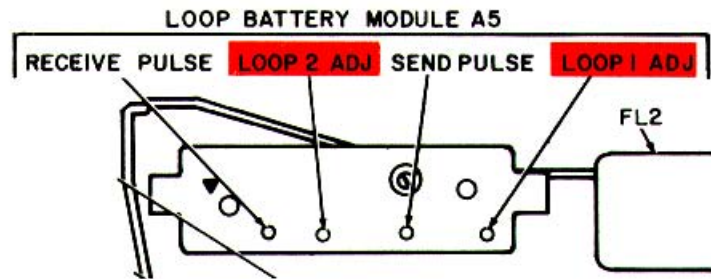
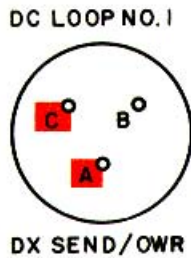

Modem Settings

CONTROL OR SWITCH

SETTING

- | | |
|---|-----------------------------------|
| <p>MODE SELECTOR
AUTO MARK HOLD
SCOPE INTENSITY</p> | <p>85 HZ
ON
FULLY CCW</p> |
|---|-----------------------------------|

PROCEDURE

INDICATION

NO

NOTE

For one given setting of the LOOP 1 ADJ or LOOP 2 ADJ potentiometers, it may not be possible to adjust both the 20 mA and 60 mA loop currents within tolerance. In this case, adjust each loop for the current to be used during operation (20 mA or 60 mA). Disregard the other current adjustment.

- | | | |
|---|----------|---------|
| 1. Adjust LOOP 1 ADJ potentiometer A5A2R15 | 60 mA +5 | |
| 2. Set DC LOOP NO. 1 current switch to 20MA. | 20 mA +5 | Go to 3 |
| 3. Readjust LOOP 1 ADJ until multimeter reading is correct. | | |
| 4. Connect multimeter's positive lead to pin A of DC LOOP NO. 2 DX RCV/PONY connector J7. Connect ground lead to pin C of J7. | | |

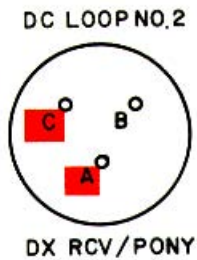

- | | | |
|---|----------|---------|
| 5. Adjust LOOP 2 ADJ potentiometer A5A2R6. | 60 mA +5 | |
| 6. Set DC LOOP NO. 2 current switch to 20MA. | 20 mA +5 | Go to 7 |
| 7. Readjust LOOP 2 ADJ until multimeter reading is correct. | | |
| 8. Set ON/OFF switch to OFF. Disconnect test setup. | | |

2-16. BFO FREQUENCY LIMITS ADJUSTMENT

Test Equipment

Electronic Digital Readout Counter ANIUSM-207

Test Connections

- Make sure that the front panel BFO control is in the center of its range.
- Remove dust cover from receive audio module A1.
- Connect electronic counter to RCVR MIXER INJ test point.

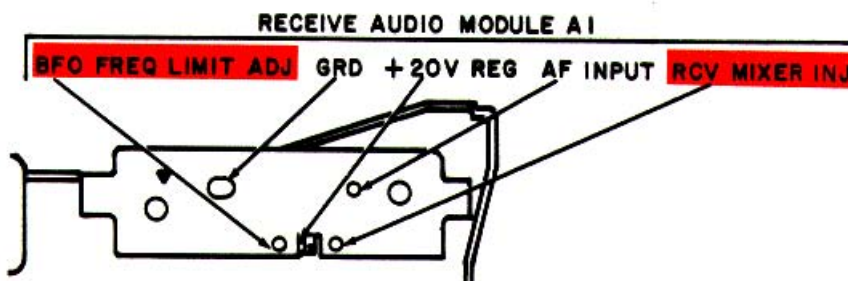

PROCEDURE	INDICATION	NO
1. Set ON/OFF switch to ON and allow a 15-minute warmup.		
2. Adjust BFO FREQ LIMIT ADJ potentiometer A1A2R7.	Counter reads 4,805 Hz + 5	
3. Rotate front panel BFO control fully counterclockwise.	Counter reading is no higher than 3,805 Hz. This is the lower frequency limit.	Go to 4, then to 5
4. Rotate front panel BFO control fully clockwise.	Counter reading is at least 5,805 Hz. This is the upper frequency limit.	Go to 5
5. Readjust BFO FREQ LIMIT ADJ until tolerances in steps 3 and 4 are met.		
6. Set ON/OFF switch to OFF. Disconnect test setup.		

2-17. SCOPE MODULE A2 CENTERING ADJUSTMENT

Test Equipment

Multimeter ME-26B/U
 Extender cable (para 2-2)

Test Connections

- Make sure ON/OFF switch is in OFF position.
- Remove scope module A2 and connect extender cable.
- Remove metal cover on the right side of the module protecting component board A2.
- Connect the positive probe of multimeter to terminal 1 and ground probe to terminal 3 of component board A2.

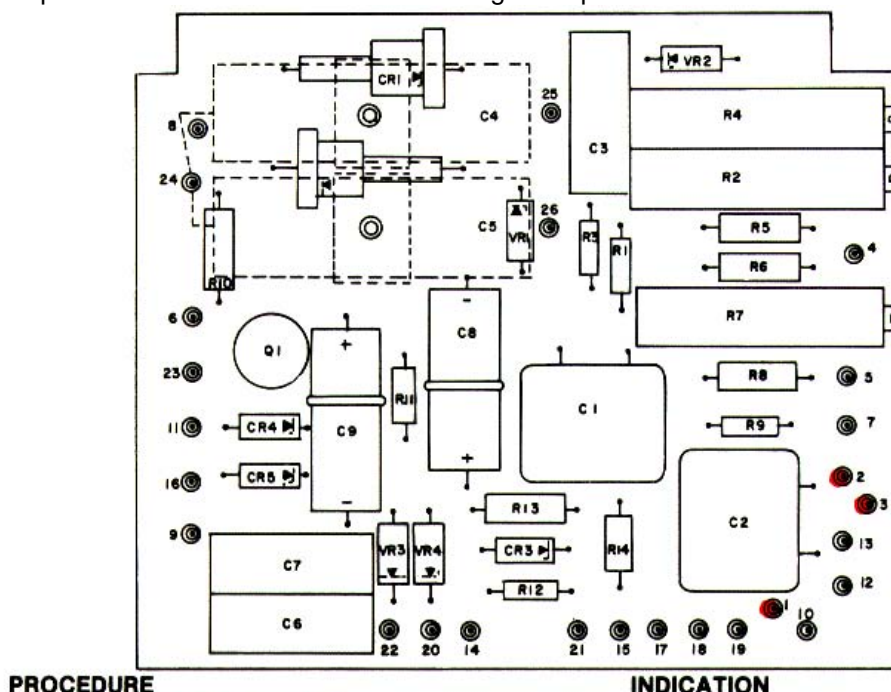

DEATH ON CONTACT may result from contact with high voltage in scope module A2. Scope module contains 1,100 volts dc. Do not touch the multimeter probes with power on.

1. Rotate front panel SCOPE INTENSITY control fully clockwise. Set ON/OFF switch ON.
2. Adjust HORIZONTAL CENTERING potentiometer A2A2R4. 0 volt
3. Set ON/OFF switch OFF. Connect multimeter positive probe to terminal 2 of component board A2.
4. Set ON/OFF switch ON. Adjust VERTICAL CENTERING potentiometer A2A2R2. 0 volt
5. Set ON/OFF switch OFF. Disconnect multimeter. Replace metal cover over component board A2A2.

2-18. SCOPE MODULE A2 ALIGNMENT

Test Equipment

Teletypewriter Test Set TS-799AIUGM-1

Multimeter ME-26BIU

Voltmeter ME-301U

Test Potentiometer, 600-ohms, 1/2-watt

Extender Cable

Test Connections

-
- Perform the centering adjustment (para 2-17)
- Make sure ON/OFF switch is in OFF position.
- Remove scope module A2 and connect extender cable.
- Remove metal cover on the left side of the module protecting component board A1.
- Connect a 600-ohm, 1/2-watt test potentiometer between OUTPUT and GRD test points on transmitter module A3.
- Measuring with the multimeter, adjust the test potentiometer for minimum resistance between the wiper and the terminal connected to the OUTPUT test point.
- Connect the wiper of the test potentiometer to pin A of AUX RCVR AUDIO connector J1.
- Adjust TS-799A/UGM-1 to operate on external loop power (supplied from the modem) and to supply an R and Y test signal.

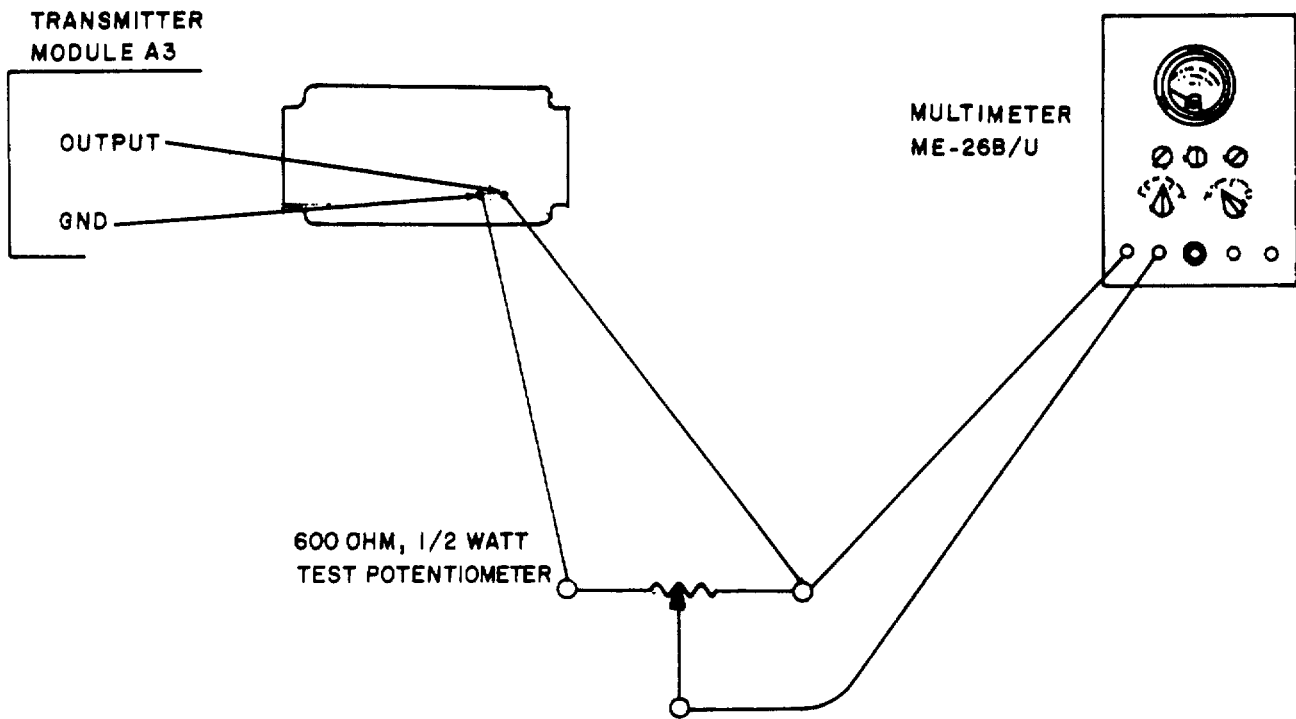

PROCEDURE

INDICATION

NO



DEATH ON CONTACT may result from contact with high voltage in scope module A2. Scope module contains 1,100 volts dc. Do not touch the multimeter probes with power on.

- | | |
|--|---|
| <ol style="list-style-type: none"> 1. Rotate SQUELCH SENS CONTROL fully cw.
Set ON/OFF switch ON. 2. Adjust BFO control. 3. Set AUTO MARK HOLD switch ON. 4. Adjust FOCUS potentiometer A2A2R7. 5. Set AUTO MARK HOLD switch OFF. 6. Adjust HORIZONTAL GAIN potentiometer A2A1R8, and VERTICAL GAIN potentiometer A2A1R13. 7. Adjust A2A1C16 and A2A1C17. | <p>Pattern is centered.</p> <p>Pattern is well defined.</p> <p>Points of Intersection of ellipses fall on horizontal and vertical axes.</p> |
|--|---|

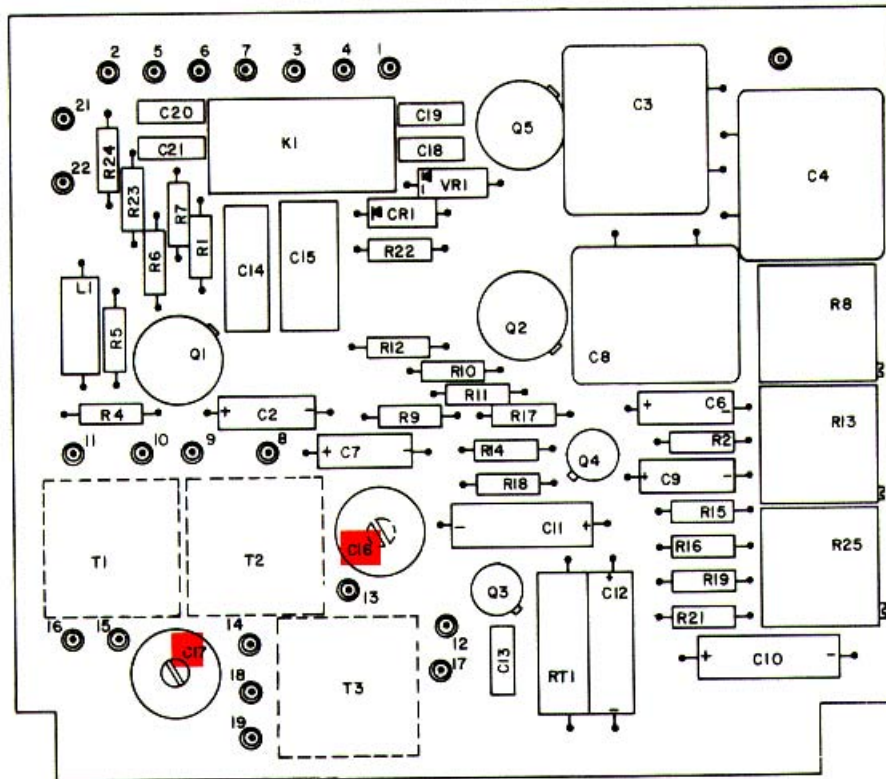

PROCEDURE

INDICATION

NO

8. Use the ME-301U to measure the voltage between the wiper of the test potentiometer connected to transmitter module A3 and the terminal of the test potentiometer connected to the GRD test point. Adjust the test potentiometer.

9 mv rms

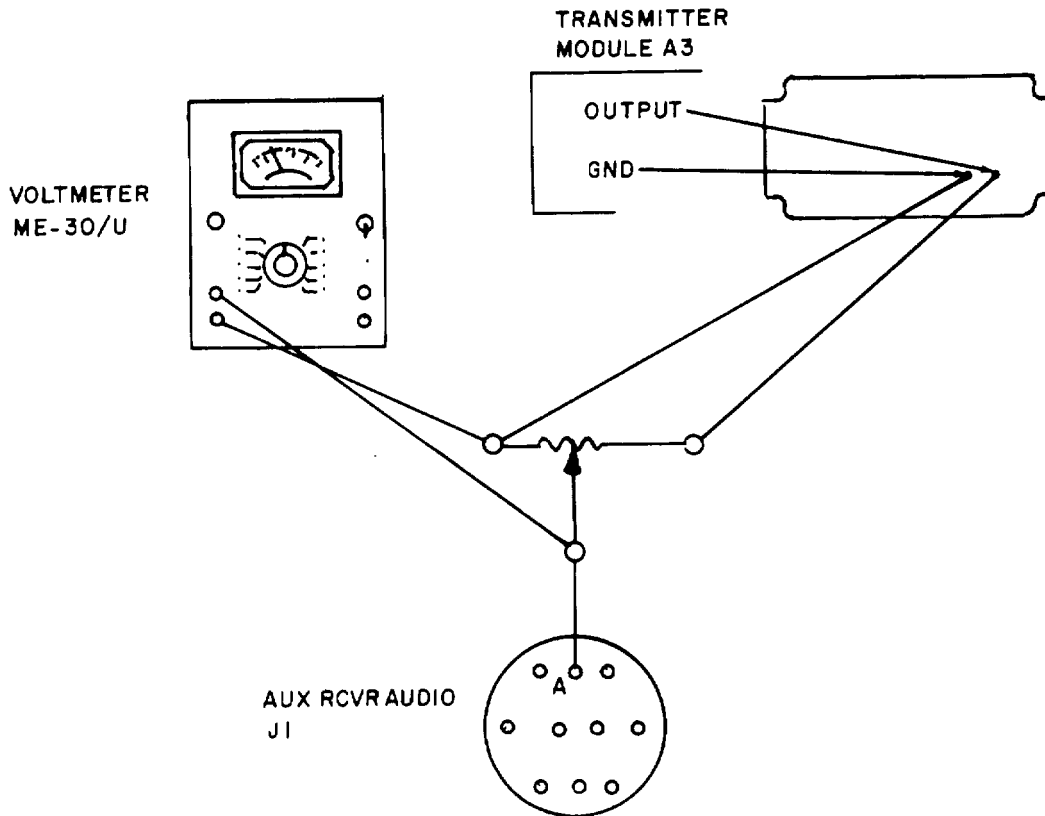

9. Adjust SQUELCH ADJ potentiometer A2A1 R25.
10. Readjust test potentiometer.

Pattern disappears

11 mv rms (pin A of J1),
Pattern reappears

Adjust SQUELCH ADJ. Repeat steps 8, 9, 10 with 9 to 11 mv rms at pin A of J1.

11. Set ON/OFF switch OFF. Turn off power to all test equipment. Replace metal cover over component board A2A1.

CHAPTER 3

INDEX

	SECTION I	PAGE
GENERAL INFORMATION		
General		3-1
Repair Parts, Tools, Test Equipment, and Materials		3-1
SECTION II		
TROUBLESHOOTING		
General Information		3-1
Modem Bench Test Setup and Test Conditions		3-2
Troubleshooting Symptom Index		3-2
Troubleshooting Chart		3-3
Test Point Measurements		3-19
SECTION III		
MAINTENANCE PROCEDURES		
Removing and Replacing Front Panel Components		3-22
Removing and Replacing Chassis Components		3-24
Adjustment Procedures		3-25

CHAPTER 3 GENERAL SUPPORT MAINTENANCE

Section I. GENERAL INFORMATION



DEATH ON CONTACT may result from contact with high voltage in modem modules. Scope module A2 contains 1,100 volts dc; loop battery module A5 contains 127 volts dc.

3-1. GENERAL

This chapter covers general support troubleshooting, maintenance, and test procedures for the modem. Section I lists the tools, test equipment, and materials needed to perform general support maintenance. Troubleshooting and test procedures are described in section II. Maintenance procedures are covered in section III. General support adjustment procedures will be the same as those for direct support (chapter 2, section IV).

3-2. REPAIR PARTS, TOOLS, TEST EQUIPMENT, AND MATERIALS

General support maintenance requires the same repair parts, tools, test equipment, and materials as for direct support (para 2-2).

Section II. TROUBLESHOOTING

3-3. GENERAL INFORMATION

The general support troubleshooting chart supplements the direct support troubleshooting chart. Refer to chapter 2, section II for troubleshooting definitions and procedures.

TEST POINT DATA:

Paragraph 3-7.

Use the troubleshooting chart to isolate defective parts.

REMOVING AND REPLACING PARTS:

Section III.

ADJUSTING AND ALIGNING MODULES:

Chapter 2, section IV.

NOTE

When conducting tests, investigate the possibility of intermittent troubles. Jarring or tapping the equipment may expose this type of problem. Do not try to correct trouble this way. Check the modem's wiring and connections to eliminate trouble caused by loose connections.

3-4. MODEM BENCH TEST SETUP AND TEST CONDITIONS

General support maintenance requires the same modem bench test setup and test conditions as for direct support (para 2-4).

3-5. TROUBLESHOOTING SYMPTOM INDEX

Use this index to quickly find procedures in the troubleshooting chart.

TROUBLESHOOTING SYMPTOM	PROCEDURE NO.	PAGE
MODEM		
Does not key transmitter	5	3-6
Does not transmit tty (MODE SELECTOR switch 85 HZ, 85 HZ DIVERSITY, 85 HZ + VOICE)	7	3-10
Does not transmit tty (MODE SELECTOR switch 850 HZ)	8	3-10
Does not transmit voice	17	3-18
Does not transmit voice (MODE SELECTOR switch VOICE, 85 HZ + VOICE)	9	3-11
Does not transmit voice or tty	6	3-9
Incorrect scope display (all M1 indications except DISCRIMINATOR)	18	3-18
ON/OFF F switch continues to trip	1	3-3
Receive tty malfunction (RCV LEVEL reading)	13	3-14
MODEM TEST METER		
Low or high REGULATED DC reading	4	3-6
No DISCRIMINATOR reading (RCV LEVEL reading and abnormal scope display)	12	3-13
No RCV LEVEL reading (receive channel functioning)	11	3-13
No RCV LEVEL reading (receive channel malfunctioning)	10	3-12
No reading	2	3-3
No receive DC LOOP current in mark-hold condition	14	3-15
No send DC LOOP current	16	3-17
No 60 MA LOOP current (with 20 MA LOOP current)	15	3-16
No + 20 volt dc reading	3	3-5

3-6. TROUBLESHOOTING CHART

Use the troubleshooting chart to localize and isolate trouble. The chart supplements the direct support troubleshooting chart of paragraph 2-6 and the foldouts at the back of this manual.

The troubleshooting chart is Indexed by MALFUNCTION/SYMPTOM for which PROBABLE CAUSES are listed. Follow the TEST PROCEDURES for which in turn an INDICATION and YES or NO instructions are given.

MALFUNCTION/SYMPTOM TEST PROCEDURE	PROBABLE CAUSE		
	INDICATION	YES	NO
(1) ON-OFF SWITCH (CB1) CONTINUES TO TRIP	Defective: Power source. Circuit breaker CB1. Circuit board A9.		
	<p style="text-align: center;">CAUTION Do not hold ON-OFF switch at ON.</p>		
1. Check polarity and voltage to PRIMARY POWER connector J8.	Proper polarity and +27 vdc	Go to 2.	Replace defective power source (TM 11-5805-387-10-2).
 <p>Do all continuity and resistance checks with all power removed.</p>			
2. On the inside of the front panel remove the L-shaped compartment housing (refer to para 2-9), check CB1 continuity with power source removed.	Continuity	Replace defective board A9 (para 2-10).	Replace defective CB1 (para 3-8).
(2) NO TEST METER OR SCOPE READINGS FOR ANY POSITION OF METER FUNCTION SWITCH.	Defective: Circuit board A9. Series regulator Transistors Q1, Q2, Q3. Connector J8.		
	1. Connect ME-26B/U across terminal 5 on board A9 (or E-37 on panel); measure voltage. Refer to figure on next page.	+22 vdc ±0.5	Go to 2.

MALFUNCTION/SYMPTOM	PROBABLE CAUSE		
	TEST PROCEDURE	INDICATION	YES

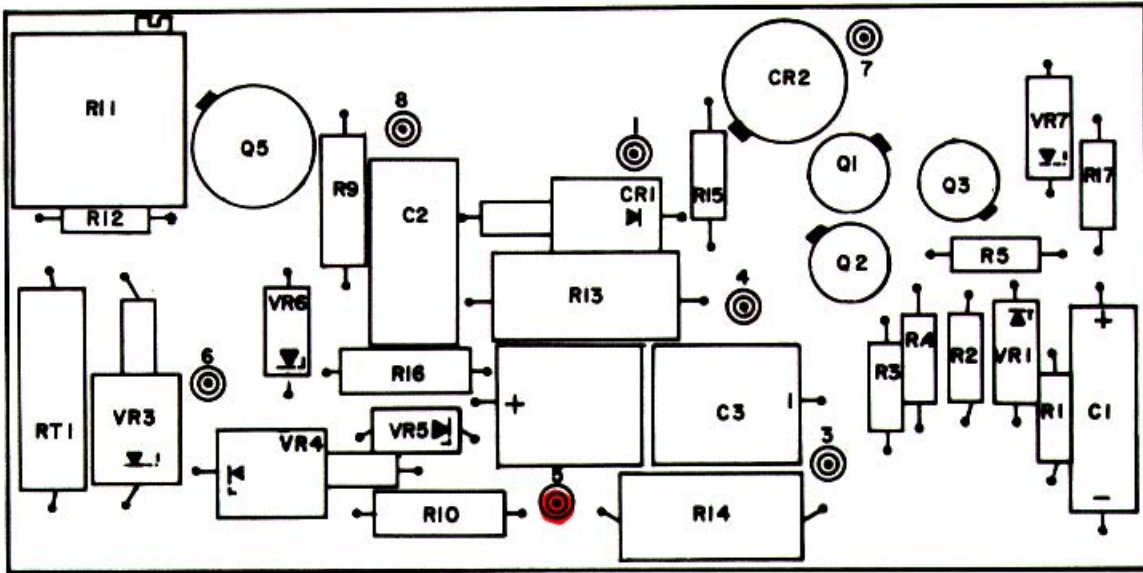

2. Check transistors Q1, Q2, Q3 for shorts to ground.

Shorts to ground

Replace defective transistor (para 2-11).

Go to 3.

3. Check transistors Q1, Q2, Q3 for open condition.

Open

Replace defective transistor (para 2-11).

Go to 4.

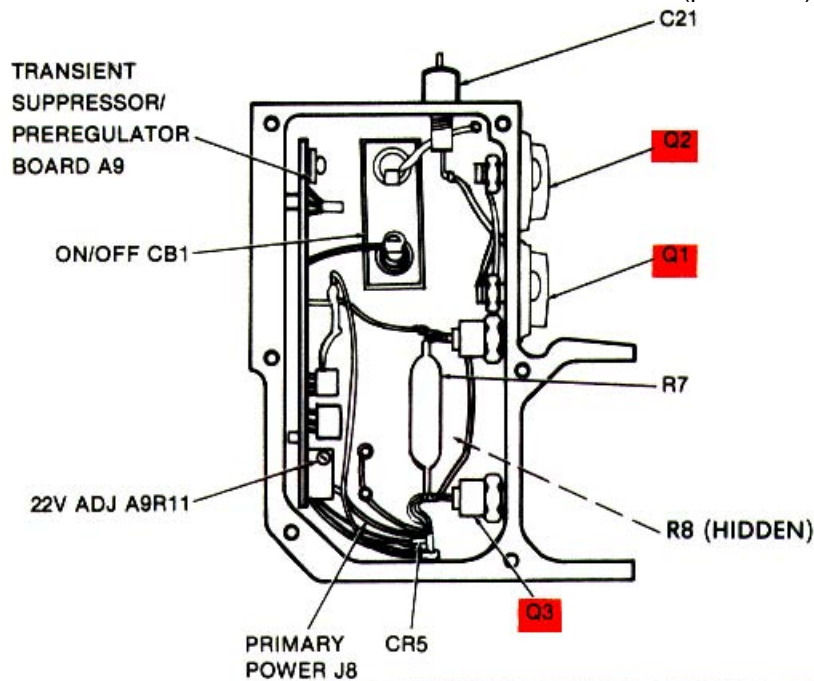

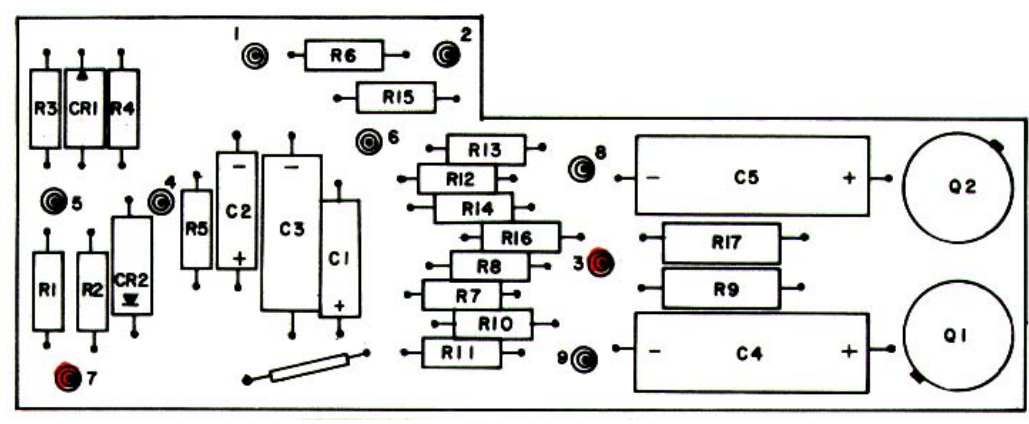
MALFUNCTION/SYMPOM	PROBABLE CAUSE		
TEST PROCEDURE	INDICATION	YES	NO
 <p>WARNING</p> <p>Do all continuity and resistance checks with all power removed.</p>			
<p>4. With power source removed and ON/OFF switch in ON position, connect ME-26B/U between terminal A of connector J8 and terminal 1 of board A9. Check for continuity.</p>	<p>Continuity defective connector J8 (para 3-8).</p>	<p>-----</p>	<p>Replace</p>
<p>(3) NO +20 VOLTS DC METER INDICATION Defective: Meter M1. Meter function switch S3. Circuit board A7.</p>			
<p>1. Connect ME-26B/U between meter M1 posts.</p>	<p>+20 vdc</p>	<p>Replace defective meter M1 (para 3-8).</p>	<p>Go to 2.</p>
<p>2. Check continuity of METER FUNCTION switch (fig. FO-8).</p>	<p>Continuity</p>	<p>Go to 3.</p>	<p>Replace defective switch S3 (para 3-8).</p>
<p>3. Connect ME-26B/U across pin 13 of XA1; measure voltage.</p>	<p>+22 vdc</p>	<p>Go to 4.</p>	<p>Replace defective wiring.</p>
<p>4. Remove cover of circuit board A7 by removing three screws and three washers. Connect ME-26B/U across terminal 3; measure voltage.</p>	<p>+20 vdc ±0.2</p>	<p>Continue test. Continue test.</p>	<p></p>
<p>Connect ME-26B/U across terminal 7; measure voltage.</p>	<p>+0.06 vdc</p>	<p>-----</p>	<p>Replace defective board A7 (para 2-10).</p>
			

MALFUNCTION/SYMP TOM	PROBABLE CAUSE		
TEST PROCEDURE	INDICATION	YES	NO
NOTE			
<p>Series regulators Q1, Q2, Q3 automatically cut off when +22 volt output of preregulator board A9 is shorted. Normal operation will resume when short is removed.</p>			
<p>1. Connect ME-26B/U across terminal 5 on board A9 (or E-37 on panel); measure voltage.</p>	<p>+22 vdc. ±0.5</p>	<p>Go to 2.</p>	<p>Replace defective board A9 (para 2-10).</p>
<p>2. Check transistors Q1, Q2, Q3 for shorts to ground.</p>	<p>Shorts to ground</p>	<p>Replace defective transistor (para 2-11).</p>	<p>Go to 3.</p>
<p>3. Check transistors Q1, Q2, Q3 for open condition.</p>	<p>Open</p>	<p>Replace defective transistor (para 2-11).</p>	
<p>(5) MODEM DOES NO KEY TRANSMITTER</p>	<p>Defective: RCV-SEND switch S5. Diodes CR1 CR2, CR3, CR4. CR6. Connectors J3, J4 (remote operation). Connector J2 (local operation). Circuit board A6.</p>		
			
<p>Do all continuity and resistance checks with all power removed.</p>			
<p>1. Check continuity of RCV/SEND switch (fig. FO-8).</p>	<p>Continuity</p>	<p>Go to 2.</p>	<p>Replace defective switch S5 (para 3-8).</p>
<p>2. Connect TS-352B/U to opposite ends of diode CR1; CR4; CR6. Measure forward and reverse resistance of each diode (figure on next page).</p>	<p>Zero ohm in one direction, infinity or high resistance in</p>	<p>Go to 3.</p>	<p>Replace defective diode (para 3-8).</p>
<p>other direction</p>			

MALFUNCTION/SYMP TOM	PROBABLE CAUSE		
	TEST PROCEDURE	INDICATION	YES

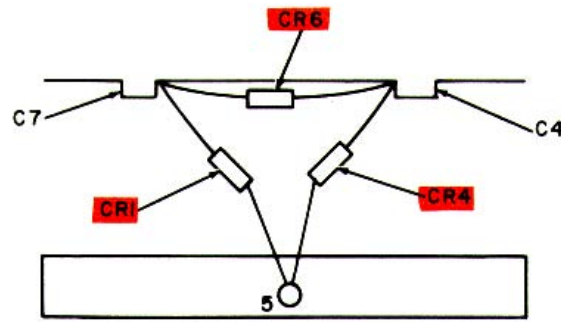

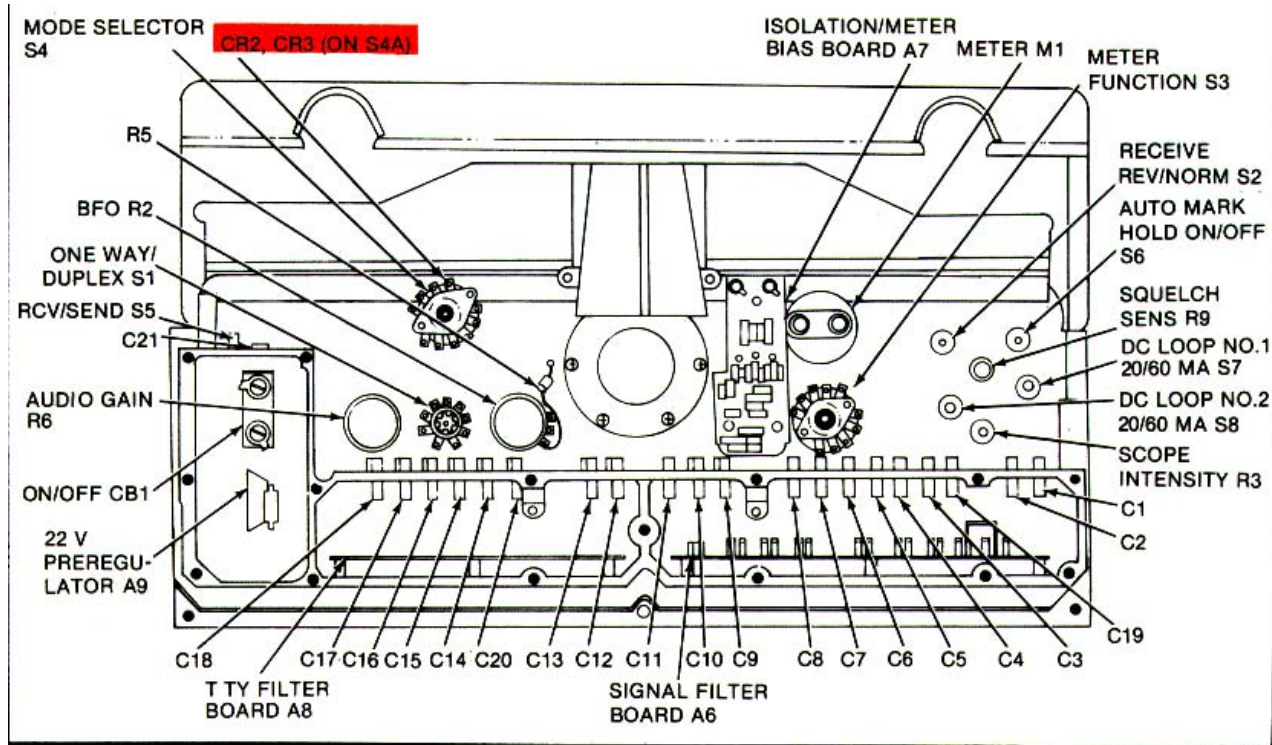

SIGNAL FILTER BOARD A6

- | | | | |
|---|--|-----------------|--|
| <p>3. Connect TS-352B/U between pin 5 of XA5 (fig. FO-8) and pin 3 of S1A-R. Measure forward and reverse resistance of diode CR2.</p> | <p>Zero ohm in one direction, infinity or high resistance in other direction</p> | <p>Go to 4.</p> | <p>Replace defective diode (para 3-8).</p> |
| <p>4. Connect TS-352B/U between pins 7 and 9 of S4A. Measure forward and reverse resistance of diode CR3.</p> | <p>Zero ohm in one direction, infinity or high resistance in other direction</p> | <p>Go to 5.</p> | <p>Replace defective diode (para 3-8).</p> |



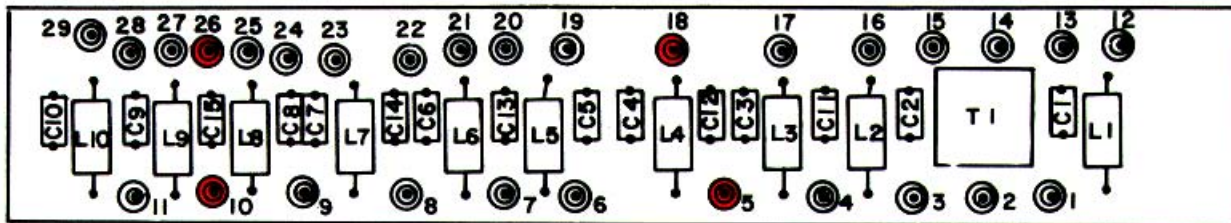



MALFUNCTION/SYMP TOM	PROBABLE CAUSE		
	TEST PROCEDURE	INDICATION	YES
5. Connect ME-26B/U between pin F of connector J2 and terminal 18 of board A6; check for continuity.	Continuity	Go to 6.	Replace defective connector J2 (para 3-8).
6. Connect ME-26B/U between pin F of connector J3 and terminal 26 of board A6; check for continuity.	Continuity	Go to 7.	Replace defective connector J3 (para 3-8).
7. Connect ME-26B/U between pin F of connector J4 and terminal 26 of board A6; check for continuity.	Continuity	Go to 8.	Replace defective connector J4 (para 3-8).
8. Connect ME-26B/U between terminals 5 and 18 on board A6; measure resistance.	4 ohms \pm 2	Go to 9.	Replace defective board A6 (para 2-10).
9. Connect ME-26B/U between terminals 10 and 26 on board A6; measure resistance.	4 ohms \pm 2	-----	Replace defective board A6 (para 2-10).





MALFUNCTION/SYMPTOM	PROBABLE CAUSE		
TEST PROCEDURE	INDICATION	YES	NO
(6) MODEM NOT TRANSMITTING EITHER VOICE OR TTY	Defective: Circuit board A6. RCV-SEND switch S5. Connector J2.		
 <p>WARNING</p> <p>Do all continuity and resistance checks with all power removed.</p>			
1. Connect ME-26B/U between terminals 2 and 13 on board A6; measure resistance.	50 ohms ±20	Go to 2.	Replace defective board A6 (para 2-10).
2. Connect ME-26B/U between terminals 14 and 15 on board A6; measure resistance.	50 ohms ±20	Go to 3.	Replace defective board A6 (para 2-10).
3. Check continuity of RCV/SEND switch (fig. FO-8).	Continuity	Go to 4.	Replace defective switch S5 (para 3-8).
4. Connect ME-26B/U between terminal J on connector J2 and terminal 14 on board A6; check for continuity.	Continuity	Go to 5.	Replace defective connector J2 (para 3-8).
5. Connect ME-26B/U between terminal D on connector J2 and terminal 15 on board A6; check for continuity.	Continuity	-----	Replace defective connector J2 (para 3-8).



MALFUNCTION/SYMPTOM	PROBABLE CAUSE		
TEST PROCEDURE	INDICATION	YES	NO
<p>(7) MODEM NOT TRANSMITTING TTY WITH MODE SELECTOR SWITCH AT 85 HZ, 85 DIVERSITY, OR 85 HZ + VOICE.</p> <p>1. Connect TS-799A/UGM-1 (refer to para 2-4) and test cable No. 3. Connect ME-30/U across terminal 2 of FL1.</p> <p>2. Connect ME-301U across terminal 4 of FL1.</p>	<p>Defective: Filter FL1.</p> <p>3.5 mv rms ±1.5</p> <p>3.5 mv rms ± 1.5</p>	<p>Go to 2.</p> <p>-----</p>	<p>Replace defective filter FL1 (para 3-9).</p> <p>Replace defective filter FL1 (para 3-9).</p>
<p>(8) MODEM NOT TRANSMITTING TTY WITH MODE SELECTOR SWITCH AT 850 Hz.</p> <p>Connect TS-799A/UGM-1 (refer to para 2-4) and test cable No. 3. Connect ME-30/U across terminal 3 of FL2.</p>	<p>Defective: Filter FL2.</p> <p>3 mv rms ±1</p>	<p>-----</p>	<p>Replace defective filter FL2 (para 3-9).</p>

MALFUNCTION/SYMP TOM	PROBABLE CAUSE		
TEST PROCEDURE	INDICATION	YES	NO
(9) MODEM NOT TRANSMITTING VOICE MODE SELECTOR SWITCH AT VOICE OR 85 HZ + VOICE.	Defective: Mode selector switch S4. Connectors J3, J4, J2. 50-ohm mike keying Circuitry. Filter FL3. Circuit board A6.		
 WARNING 			
Do all continuity and resistance checks with all power removed.			
1. Check continuity of MODE SELECTOR switch wafers S4B, S4C, S4G (fig. FO-8, fig. FO-11).	Continuity	Go to 2.	Replace defective switch S4 (para 3-8).
2. Check continuity of connector J3 (local operation), connectors J4 or J2 (remote operation) (fig. FO-8, fig. FO-11).	Continuity	Go to 3.	Replace defective connector (para 3-8).
3. Remove transmitter module A3. Check continuity of 50-ohm mike keying circuit components external to module A3: diode CR4, RCV/SEND switch S5, circuit board A6, feed through capacitors C4, C9, C17, C18 (fig. FO-11).	Continuity	Go to 4.	Replace defective component.
4. Connect AN/USM-207 across terminal 1 of filter FL3. Speak Into mike.	200 - 2,300 Hz	Continue test.	Continue test.
Connect AN/USM-207 across terminal 3 of filter FL3. Speak Into mike.	200 - 2,300 Hz	Go to 5.	Replace defective filter FL3 (para 3-9).
 WARNING 			
Do all continuity and resistance checks with all power removed.			
5. Connect ME-26B/U between pin C of connector J3 and terminal 7 of board A6. Check for continuity.	Continuity	Go to 6.	Replace defective board A6 (para 2-10).
6. Connect ME-26B/U between pin C of connector J2 and terminal 4 of board A6. Check for continuity.	Continuity	-----	Replace defective board A6 (para 2-10).

MALFUNCTION/SYMPTOM	PROBABLE CAUSE		
TEST PROCEDURE	INDICATION	YES	NO
<p>(10) NO RCV LEVEL READING ON METER M1. RECEIVE CHANNEL MALFUNCTIONING.</p>	<p>Defective: One way-duplex switch S1. Circuit board A6. Connector J1 or J2.</p>		
<p>NOTE</p>			
<p>There will be no RCV LEVEL indication when using test cable No. 3.</p>			
 <p>WARNING</p>			
<p>Do all continuity and resistance checks with all power removed.</p>			
<p>1. Check continuity of ONE WAY/DUPLEX switch (fig. FO-8).</p>	<p>Continuity</p>	<p>Go to 2.</p>	<p>Replace defective switch S1 (para 3-8).</p>
<p>2. Connect ME-26B/U between pin C of connector J3 and terminal 7 of board A6.</p>	<p>Continuity</p>	<p>Go to 3.</p>	<p>Replace defective board A6 (para 2-10).</p>
<p>3. Connect ME-26B/U between pin C of connector J2 and terminal 4 of board A6.</p>	<p>Continuity</p>	<p>Go to 4.</p>	<p>Replace defective board A6 (para 2-10).</p>
<p>4. Connect ME-26B/U between pin A of connector J1 and terminal 12 of board A6.</p>	<p>Continuity</p>	<p>Go to 5.</p>	<p>Replace defective connector J1 (para 3-8).</p>
<p>5. Connect ME-26B/U between pin A of connector J2 and terminal 16 of board A6.</p>	<p>Continuity</p>	<p>-----</p>	<p>Replace defective connector J2 (para 3-8).</p>

MALFUNCTION/SYMP TOM	PROBABLE CAUSE		
TEST PROCEDURE	INDICATION	YES	NO
<p>(11) NO RCV LEVEL READING ON METER M1. RECEIVE CHANNEL FUNCTIONING.</p> <div style="text-align: center;">  <p>WARNING</p> <p>Do all continuity and resistance checks with all power removed.</p> </div> <p>1. Check continuity of METER FUNCTION switch (fig. FO-8).</p> <p>2. Remove cover of circuit board A7 by removing three screws and three washers. Connect ME-26B/U across terminal 3 of board A7; measure voltage. Connect ME-26B/U across terminal 7 of board A7; measure voltage.</p>	<p>Defective: Meter function switch S3. Circuit board A7.</p> <p>Continuity</p> <p>+20 vdc ±0.2</p> <p>0.06 vdc</p>	<p>Go to 2.</p> <p>Continue test.</p> <p>-----</p>	<p>Replace defective switch S3 (para 3-8).</p> <p>Continue test.</p> <p>Replace defective board A7 (para 2-10).</p>
<p>(12) RCV LEVEL READING ON TEST METER, NO DISCRIMINATOR READING. ABNORMAL SCOPE DISPLAY.</p> <p>1. Remove cover of circuit board A7 by removing three screws and three washers. Connect ME-26B/U across terminal 3 of board A7; measure voltage. Connect ME-26B/U across terminal 7 of board A7; measure voltage.</p>	<p>Defective: Circuit board A7. Relay K1. Filter FL6. Filter FL7.</p> <p>+20 vdc ±0.2</p> <p>0.06 vdc or nominal voltage</p>	<p>Continue test. Continue test.</p> <p>Go to 2.</p>	<p>Replace defective board A7 (para 2-10).</p>

MALFUNCTION/SYMP TOM	PROBABLE CAUSE		
TEST PROCEDURE	INDICATION	YES	NO
 <p>WARNING</p> <p>Do all continuity and resistance checks with all power removed.</p>			
2. Remove module A4 (para 2-8). Check continuity of relay K1 with MODE SELECTOR switch at positions 850 HZ and 85 HZ (fig. FO-8).	Continuity	Go to 3.	Replace defective relay K1 (para 3-9).
3. Replace module A4; set MODE SELECTOR switch at 85 HZ DIVERSITY. Connect TS-799AIUGM-1 (para 2-4) and test cable No. 3. Check for signal continuity across terminal 1 of filter FL6 (fig. FO-8).	Input signal present on AN/USM-281A	Go to 4.	Replace defective filter FL6 (para 3-9).
4. Set MODE SELECTOR switch at 850 HZ. Check for signal continuity across terminal 3 of filter FL7 (fig. FO-8).	Input signal present on AN/USM-281A	-----	Replace defective filter FL7 (para 3-9).
(13) RCV LEVEL READING ON METER M1. RECEIVE TTY MALFUNCTION	Defective: Mode selector switch S4. Filter FL4. Relay K1. Filter FL6. Filter FL7.		
 <p>WARNING</p> <p>Do all continuity and resistance checks with all power removed.</p>			
1. Check continuity of MODE SELECTOR switch wafer S4D (fig. FO-8).	Continuity	Go to 2.	Replace defective switch S4 (para 3-8).
2. Set MODE SELECTOR switch at 85 HZ DIVERSITY. Connect TS-799A/UGM-1 (para 2-4) and test cable No. 3. Check for signal continuity across terminal 2 of filter FL4 (fig. FO-8).	Input signal present on AN/USM-281	Go to 3.	Replace defective filter FL4 (para 3-9).
3. Check for signal continuity across terminal 4 of filter FL4 (fig. FO-8). AN/USM-281	Input signal present on	Go to 4.	Replace defective filter FL4 (para 3-9).

MALFUNCTION/SYMPOM	PROBABLE CAUSE		
TEST PROCEDURE	INDICATION	YES	NO
 <p>WARNING</p> <p>Do all continuity and resistance checks with all power removed.</p>			
4. Remove receiver module A4 (para 2-8). Check continuity of relay K1 with MODE SELECTOR switch at positions 850 HZ and 85 HZ (fig. FO-8).	Continuity	Go to 5.	Replace defective relay K1 (para 3-9).
5. Replace module A4, set MODE SELECTOR switch at 85 HZ DIVERSITY. Check for signal continuity across terminal 1 of filter FL6 (fig. FO-8).	Input signal present on AN/USM-281A	Go to 6.	Replace defective filter FL6 (para 3-9).
6. Set MODE SELECTOR switch at 850 HZ. Check for signal continuity across terminal 3 of filter FL7 (fig. FO-8).	Input signal present on AN/USM-281A	-----	Replace defective filter FL7 (para 3-9).
(14) NO CURRENT IN RECEIVE DC LOOP, MODEM IN MARK-HOLD CONDITION.	Defective: Meter function switch S3. Connector J7. Circuit board A8.		
 <p>WARNING</p> <p>Do all continuity and resistance checks with all power removed.</p>			
1. Check continuity of METER FUNCTION switch (fig. FO-8).	Continuity	Go to 2.	Replace defective switch S3 (para 3-8).
2. Connect ME-26B/U between pin A of connector J7 and terminal 10 of board A8. Check for continuity.	Continuity	Go to 3.	Replace defective connector J7 (para 3-8).
3. Connect ME-26B/U between pin C of connector J7 and terminal 11 of board A8. Check for continuity.	Continuity	Go to 4.	Replace defective connector J7 (para 3-8).

MALFUNCTION/SYMP TOM	PROBABLE CAUSE		
	TEST PROCEDURE	INDICATION	YES
4. Connect ME-26B/U between terminals 2 and 3 on board A8. Measure voltage.	120 to 140 vdc	Go to 5.	Replace defective board A8 (para 2-10).
5. Connect ME-26B/U between terminals 4 and 5 on board A8. Measure voltage.	120 to 140 vdc	Go to 6.	Replace defective board A8 (para 2-10).
6. Connect ME-26B/U between terminals 10 and 11 on board A8. Measure voltage.	120 to 140 vdc	-----	Replace defective board A8 (para 2-10).

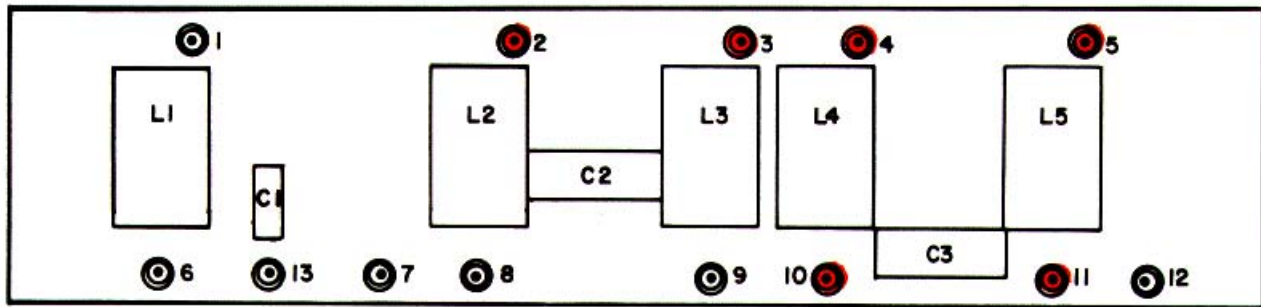

(15) 20-MA LOOP CURRENT, BUT NO 60-MA LOOP CURRENT.



Defective: Dc loop no. 1 switch S7. Dc loop no. 2 switch S8.



Do all continuity and resistance checks with all power removed.

1. Check continuity of DC LOOP NO. 1 switch (fig. FO-8).	Continuity	Go to 2.	Replace defective switch S7 (para 3-8).
2. Check continuity of DC LOOP NO. 2 switch (fig. FO-8).	Continuity	-----	Replace defective switch S8 (para 3-8).

MALFUNCTION/SYMP TOM	PROBABLE CAUSE		
TEST PROCEDURE	INDICATION	YES	NO
(16) NO CURRENT IN SEND DC LOOP.	Defective: Meter function switch S3. Connector J6. Circuit board A8.		
 <p>Do all continuity and resistance checks with all power removed.</p>			
1. Check continuity of METER FUNCTION switch (fig. FO-8).	Continuity	Go to 2.	Replace defective switch S3 (para 3-8).
2. Connect ME-26B/U between pin A of connector J6 and terminal 8 of board A8. Check for continuity.	Continuity	Go to 3.	Replace defective connector J6 (para 3-8).
3. Connect ME-26B/U between pin C of connector J6 and terminal 9 of board A8.	Continuity	Go to 4.	Replace defective connector J6 (para 3-8).
4. Connect ME-26B/U between terminals 2 and 3 on board A8. Measure voltage.	120 to 140 vdc	Go to 5.	Replace defective board A8 (para 2-10).
5. Connect ME-26B/U between terminals 4 and 5 on board A8. Measure voltage.	120 to 140 vdc	Go to 6.	Replace defective board A8 (para 2-10).
6. Connect ME-26B/U between terminals 10 and 11 on board A8. Measure voltage.	120 to 140 vdc	-----	Replace defective board A8 (para 2-10).

MALFUNCTION/SYMP TOM	PROBABLE CAUSE		
TEST PROCEDURE	INDICATION	YES	NO
<p>(17) MODEM NOT TRANSMITTING VOICE.</p> <div style="text-align: center;">  <p>Do all continuity and resistance checks with all power removed.</p> </div> <ol style="list-style-type: none"> 1. Check continuity of MODE SELECTOR switch wafers S4B, S4C, S4G (fig. FO-8, fig. FO-11). 2. Check continuity of connector J3 (local operation), connectors J4 or J2 (remote operation) (fig. FO-8, fig. FO-11). 3. Remove transmitter module A3. Check continuity of 50-ohm mike keying circuit components external to module A3: diode CR4, RCV/SEND switch S5, circuit board A6, feed through capacitors C4, C9, C17, C18 (fig. FO-11). 4. Connect ME-26B/U between pin C of connector J3 and terminal 7 of board A6. Check for continuity. 5. Connect ME-26B/U between pin C of connector J2 and terminal 4 of board A6. Check for continuity. 	<p>Defective: Mode selector switch S5. Connectors J3, J4, J2. 50-ohm mike keying circuitry. Circuit board A6.</p>	<p>Go to 2.</p> <p>Go to 3.</p> <p>Go to 4.</p> <p>Go to 5.</p> <p>-----</p>	<p>Replace defective switch S4 (para 3-8).</p> <p>Replace defective connector (para 3-8).</p> <p>Replace defective component.</p> <p>Replace defective board A6 (para 2-10).</p> <p>Replace defective board A6 (para 2-10).</p>
<p>(18) ABNORMAL SCOPE PRESENTATION BUT NORMAL DISCRIMINATOR INDICATION ON TEST METER.</p> <div style="text-align: center;">  <p>DEATH ON CONTACT may result from contact with the terminals of R3. With module A2 operating, -800 volts dc appears on scope intensity control resistor R3. Do the following continuity check with all power removed.</p> </div> <p>Remove scope module A2 (refer to para 2-8). Check continuity of variable resistor R3 (fig. FO-8).</p>	<p>Defective: Resistor R3.</p>	<p>-----</p>	<p>Replace defective resistor R3 (para 3-8).</p>

3-7. TEST POINT MEASUREMENTS

CAUTION

Do not short the test point jacks to the modem chassis. This could cause equipment damage.
General Instructions

-
- Test equipment: See paragraph 2-2.
- Bench setup and test conditions: See paragraph 2-4.

Procedures

- The values listed in the charts below are for troubleshooting purposes only; they represent average values measured at designated test points.
- Use the signal generator for MODEM INPUT.
- Use the voltmeter to measure across test points.

Test Point Charts

- Test point chart 2: Front panel and chassis test points.
- Test point chart 3: Transistor Q1, Q2, Q3 voltage chart.

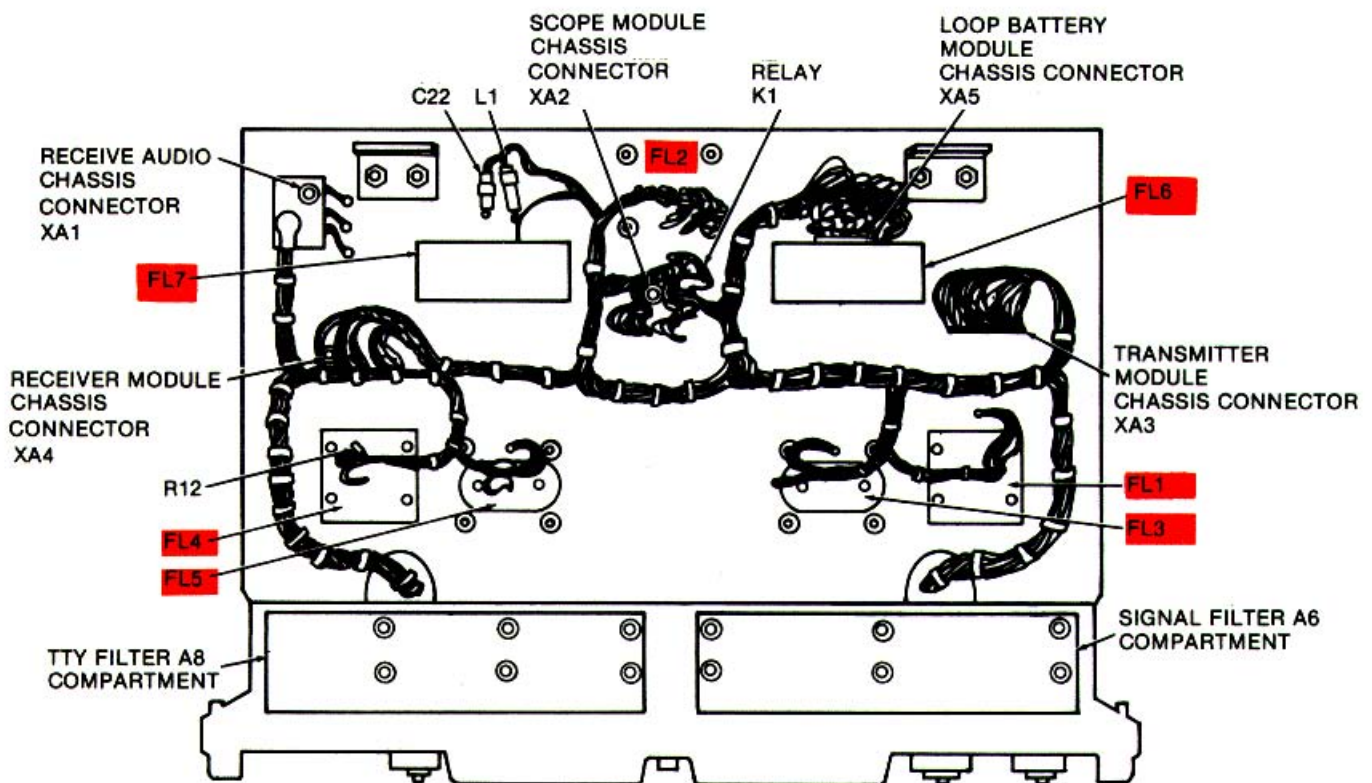

TEST POINT CHART 2

TEST POINT	MODEM INPUT	MODEM SWITCH SETTING	INDICATION
1. Chassis terminal E22	No input needed.	ON/OFF switch: ON	22.0 volts dc ±0.5
2. Chassis terminal E23	No Input needed.	ON/OFF switch: ON	20.0 volts dc ±0.5
3. FL1-1	Test cable No. 3 connected.	MODE SELECTOR: All 85-HZ modes	12 mv rms ±2
4. FL1-2	Test cable No. 3 connected.	MODE SELECTOR: All 85-HZ modes	3.5 mv rms ± 1.5
5. FL1-3	Test cable No. 3 connected.	MODE SELECTOR: 85 HZ DIVERSITY	15 mv rms ±4
6. FL1-4	Test cable No. 3 connected.	MODE SELECTOR: All 85-HZ modes	3.5 mv rms ± 1.5
7. FL2-1	Test cable No. 3 connected.	MODE SELECTOR: 850 HZ	15 mv rms ±4
8. FL2-3	Test cable No. 3 connected.	MODE SELECTOR: 850 HZ	3 mv rms ±1
9. FL3-1	1 kHz, 200 mv signal at J3-J.	MODE SELECTOR: 85 HZ + VOICE	125 mv rms ±25
10. FL3-3	1 kHz, 200 mv signal at J3-J.	MODE SELECTOR: 85 HZ + VOICE	140 mv rms ±35

NOTE

FL4 measurements made with module A4 removed from chassis.

11. FL4-1	2,805 Hz, 2.45 volts rms at J1-A.	MODE SELECTOR: 85 HZ DIVERSITY	2.45 volts rms
12. FL4-2	2,805 Hz, 2.45 volts rms at J1-A.	MODE SELECTOR: 85 HZ DIVERSITY	2.0 volts rms ±0.4
13. FL4-3	425 Hz, 2.45 volts rms at J1-A.	MODE SELECTOR: 85 HZ DIVERSITY	3.0 volts rms ±0.6
14. FL4-4	425 Hz, 2.45 volts rms at J1-A.	MODE SELECTOR: 85 HZ DIVERSITY	2.6 volts rms ±0.5
15. FL5-1	1 kHz, 1-volt rms signal at J1-A.	MODE SELECTOR 85 HZ + VOICE	900 mv rms ±100
16. FL5-3	1 kHz, 1-volt rms signal at J1-A.	MODE SELECTOR: 85 HZ + VOICE	1.0 volt rms ±0.2
17. FL6-1	425 Hz, 2.45 volts rms at J1-A.	MODE SELECTOR: 85 HZ DIVERSITY	200 mv rms ±40
18. FL6-3	425 Hz, 2.45 volts rms at J1-A.	MODE SELECTOR: 85 HZ DIVERSITY	

TEST POINT CHART 2 - Continued

TEST POINT	MODEM INPUT	MODEM SWITCH SETTING	INDICATION
19. FL7-1	2,805 Hz, 2.45 volts rms at J1-A.	MODE SELECTOR: 850 HZ	275 mv rms \pm 50
20. FL7-3	2,805 Hz, 2.45 volts rms at J1-A.	MODE SELECTOR: 850 HZ	110 mv rms \pm 30
21. R2 (cw terminal)	No input needed.	MODE SELECTOR: 850 HZ	20.0 volts dc \pm 0.5
22. R2 (center terminal)	No input needed.	MODE SELECTOR: 850 HZ (BFO fully ccw)	3.6 volts p-p \pm 0.6
23. R2 (center terminal)	No input needed.	MODE SELECTOR: 850 HZ (BFO fully cw)	20.0 volts do \pm 0.5

TEST POINT CHART 3

TEST POINT	EMITTER	BASE	COLLECTOR
Q1	23 \pm 1 volts	22.4 \pm 1 volts	27 \pm 1 volts
Q2	23 \pm 1 volts	22.4 \pm 1 volts	27 \pm 1 volts
Q3	26.3 \pm 1 volts	27 \pm 1 volts	23 \pm 1 volts

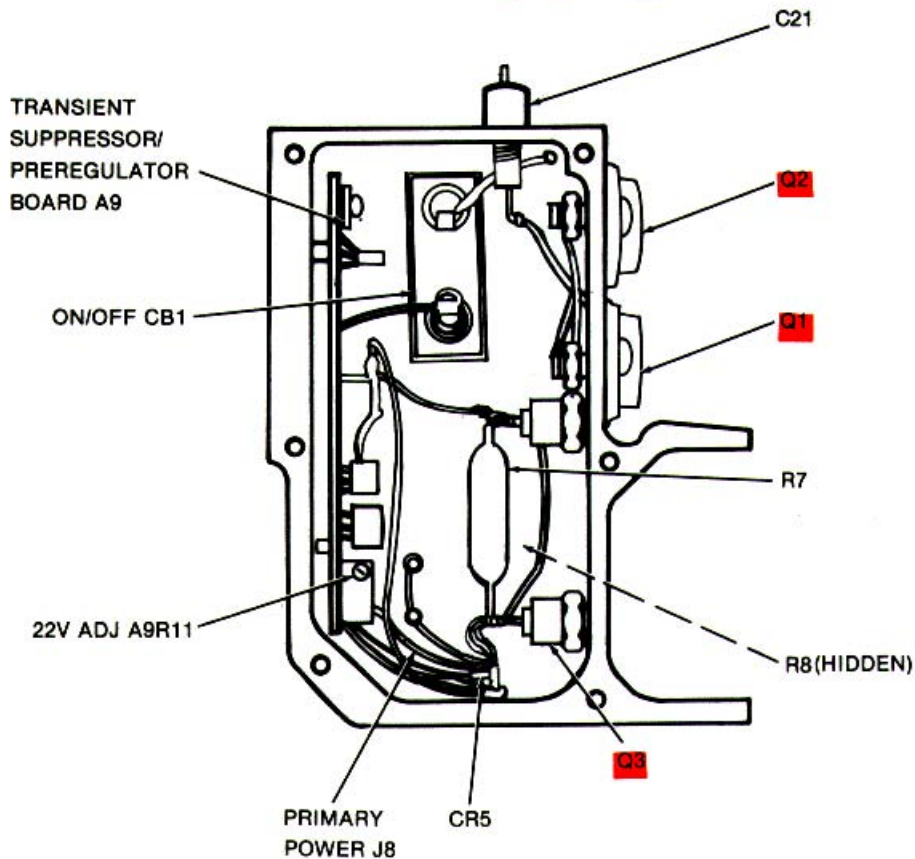

Section III. MAINTENANCE PROCEDURES

3-8. REMOVING AND REPLACING FRONT PANEL COMPONENTS

NOTE

For all procedures in this paragraph, follow instructions in paragraph 2-9 for removing and replacing the front panel.

CONNECTORS J1, J2, J3, J4

REMOVE

- Remove printed circuit board A6 from compartment housing (para 2-10).
- Remove hex nut (connector J1, J2) or spanner nut (J3, J4) holding connector to front panel.
- Carefully push connector out from inside the panel.
- Connectors J3, J4: Tag, unsolder, and remove wires from connector. Remove connector.
- Connectors J1, J2: Unscrew rubber bushing retainer ring. Push the bushing back against wires, away from connector, to expose solder terminals. Tag, unsolder, and remove wires from connector; remove connector.

REPLACE

- Solder wires to new connector.
- Connectors J1 and J2: Replace screws on rubber bushing retainer ring.
- Carefully push connector into front panel.
- Replace hex nut (J1, J2) or spanner nut (J3, J4).
- Replace printed circuit board A6 (para 2-10).

CONNECTORS J5, J6, J7, J8

REMOVE

- Remove printed circuit board A8 from compartment housing (para 2-10).
- Remove hex nut or spanner nut (J8) holding connector to front panel.
- Carefully push connector out from inside of panel.
- Unscrew rubber bushing retainer ring. Push the bushing back against wires, away from connector, to expose solder terminals.
- Tag, unsolder, and remove wires from connector; remove connector.

REPLACE

- Solder wires to new connector.
- Replace screws on rubber bushing retainer ring.
- Carefully push connector into front panel.
- Replace nut.
- Replace printed circuit board A8 (para 2-10).

MODEM SWITCHES

S1 ONE WAY/DUPLEX
 S2 RECEIVE
 S3 METER FUNCTION
 S4 MODE SELECTOR
 S5 RCV/SEND
 S6 AUTO MARK HOLD
 S7 DC LOOP NO. 1
 S8 DC LOOP NO. 2

REMOVE

- Tag, unsolder, and remove all wires connected to switch terminals.
- On front panel remove control knob retainer screw or hex nut.
- On inside of front panel remove any hex nuts.
- Carefully push switch out from outside of panel.

REPLACE**CAUTION**

Wafer switch terminals are easily bent and broken. When installing a new switch containing wafers, carefully position wiring harness to prevent strain on switch terminals.

- Place new switch into position.
- On inside of front panel replace any hex nuts.
- On front panel replace control knob retainer screw or hex nut.
- Solder wires to new switch terminals.

CIRCUIT BREAKER CB1**REMOVE**

-
- Tag, unsolder, and remove wires from circuit breaker terminals.
- Remove hex nut on front panel ON/OFF switch.
- Remove circuit breaker.

REPLACE

-
- Place new circuit breaker into position.
- Tighten hex nut on front panel.
- Solder wires to circuit breaker terminals.

DIODES CR1-CR6**REMOVE**

- Tag, unsolder, and remove leads from diode.
- Remove diode.

REPLACE

-
- Position new diode.
- Solder leads to new diode.

VARIABLE RESISTORS

R1 AUDIO GAIN
 R2 BFO
 R3 SCOPE INTENSITY
 R9 SQUELCH SENS

REMOVE

- Tag, unsolder and remove leads from resistor.
- Remove control knob retainer screws.
- Remove resistor.

REPLACE

- Put new resistor in place.
- Replace control knob retainer screws.
- Solder leads to new resistor.

METER M1

CAUTION

Do not press on meter glass.

REMOVE

- Tag and unsolder wire leads to meter terminals.
- Remove four front panel screws.
- Remove meter.

REPLACE

- Install new meter.
- Replace four front panel screws.
- Solder wires to meter.

3-9. REMOVING AND REPLACING CHASSIS COMPONENTS

- To gain access to chassis components, remove modem from chassis (para 2-8).
- Stand modem on end for simultaneous access to top and bottom of chassis.

FILTERS FL1, FL2, FL3, FL4, FL5

REMOVE

- On the bottom side of the chassis remove four hex nuts holding filter to chassis.
- Tag, unsolder and remove leads from terminals.
- Lift out filter.

REPLACE

- Place new filter into position.
- Tighten four hex nuts.
- Solder leads to filter terminals.

FILTERS FL6, FL7**REMOVE**

- On the top side of the chassis remove two hex nuts holding filter to chassis.
- Tag, unsolder and remove leads from terminals.
- Lift out filter.

REPLACE

- Place new filter into position.
- Tighten two hex nuts.
- Solder leads to filter terminals.

RELAY K1**REMOVE**

- Tag, unsolder and remove all wires from relay.
- Remove 2 captive screws holding relay to compartment housing.
- Remove relay.

REPLACE

- Position relay on compartment housing.
- Replace captive screws.
- Solder wires to relay terminals.

3-10. ADJUSTMENT PROCEDURES

General support adjustment procedures are the same as direct support procedures. Refer to chapter 2, section IV.

APPENDIX A

REFERENCES

A-1. INTRODUCTION

The Consolidated Index of Army Publications and Blank Forms, DA PAM 310-1 should be consulted frequently for revisions and new publications that pertain to this manual. The following is a list of all forms, technical bulletins, and technical manuals referenced in this manual.

A-2. FORMS

DA Form 2028	Recommended Changes to Publication and Blank Forms
DA Form 2404	Equipment Inspection and Maintenance Worksheet
SF Form 361	Discrepancy in Shipment Report
SF Form 364	Report of Discrepancy (ROD)
SF Form 368	Quality Deficiency Report

A-3. TECHNICAL BULLETINS

TB 43-0116	Identification of Radioactive Items in the Army Supply System
TB 43-0122	Instructions for the Safe Handling and Identification of the US Army Communications-Electronics Command Managed Radioactive Items in the Army Supply System
TB 385-4	Safety Precautions for Maintenance of Electrical/Electronic Equipment

A-4. TECHNICAL MANUALS

TM 11-5805-387-10-1	Operator Maintenance Manual: Radio Teletypewriter Modem MD-522/GRC (NSN 5815-00-999-5277)
TM 11-5805-387-10-2	Organizational Maintenance Manual: Radio Teletypewriter Modem MD-522A/GRC (NSN 5815-00-819-4800)
TM 11-5805-387-15-2	Operator's, Organizational, Direct Support, General Support, and Depot Maintenance Manual: Modem, Radio Teletypewriter MD-522/G RC (NSN 5815-00-999-5277)
TM 11-5805-387-20-1	Organizational Maintenance Manual: Radio Teletypewriter Modem MD-522A/GRC (NSN 5815-00-999-5277)
TM 11-5805-387-20-2	Organizational Maintenance Manual: Radio Teletypewriter Modem MD-522A/GRC (NSN 5815-00-919-4800)
TM 11-5805-387-20P-2	Organizational Repair Parts List: Modem, Radio Teletypewriter MD-522A/G RC
TM 11-5805-387-24P-1	Organizational, Direct Support and General Support Maintenance Repair Parts and Special Tools Lists (Including Depot Maintenance Repair Parts and Special Tools) for Modem, Radio Teletypewriter MD-522/G RC (NSN 5815-00-999-5277)

- TM 11-5805-387-34P-2 Direct Support and General Support Maintenance Repair Parts and Special Tools Lists (Including Depot Maintenance Repair Parts and Special Tools) for Radio Teletypewriter Modem MD-522A/GRC (NSN 5805-00-919-4800)
- TM 11-5815-334-12 Operator's and Organizational Maintenance Manual for Radio Teletypewriter Sets AN/G RC-142, AN/G RC-142A (NSN 5815-00-401-9720), AN/G RC-1 42B (5815-00-443-5511), AN/G RC-142C (5815-01-100-6815), AN/G RC-142D (5815- 01-104-7264), AN/G RC-142E (5815-01-095-6258), AN/G RC-122, AN/G RC-122A (5815-00-401-9719), AN/G RC-122B (5815-00-937-5295), AN/G RC-122C (5815-01-095-1211), AN/G RC-122D (5815-01-104-7264) and AN/G RC-122E (5815-01-095-1212) (Reprinted w/basic including C1-9)
- TM 11-5815-334-34 Direct Support, General Support, and Depot Maintenance Manual, Radio Teletypewriter Sets AN/G RC-142, AN/G RC-142A (NSN 5815-00-401-9720), AN/G RC-142B (5815-00-443-5511), AN/G RC-142C (5815-01-100-6815), AN/GRC-142D (5815-01-104-7264), AN/GRC-142E (5815-01-095-6258), AN/G RC-1 22 and AN/G RC-122A (5815-00-401-9719), AN/G RC-122B (5815-00-937-5296), AN/GRC-122C (5815-01-095-1211), AN/GRC-122D (5185-01-104-7264) and AN/GRC-122E (5815-095-1212) (Reprinted w/basic and C1-4)
- TM 11-5965-202-35 Department of the Army and Air Force (TO 31W1-2PT-364) Technical Manual: Field and Depot Maintenance; Handsets H-330/PT, H-33E/PT, and H-33F/PT
- TM 11-6130-247-15 Operator's, Organizational, Direct Support, General Support, and Depot Maintenance Manual for Power Supply, PP-3940/6
- TM 11-6625-200-15 Operator's, Organizational, Direct Support, General Support, and Depot Maintenance Manual: Multimeters ME-26A/U (NSN 6625-00-360-2493), ME-268/U and ME-28C/U (6625-00-646-9409), and ME-26D/U (6625-00-913-9781) (Reprinted w/basic including C1-3)
- TM 11-6625-320-12 Operator's and Organizational Maintenance Manual: Volt- meter, Meter ME-30A/U and Voltmeters, Electronic, ME-30B/U, ME-30C/U and ME-30E/U
- TM 11-6625-366-15 Operator's, Organizational, Direct Support, General Support, and Depot Maintenance Manual: Multimeter TS-352B/U (NSN 6625-00-553-0142) (Reprinted w/basic including C1-4)
- TM 11-6625-524-15-1 Operator's, Organizational, Direct Support, General Support, and Depot Maintenance Manual: Electronic Voltmeter, AN/U RM-145 (NSN 6625-00-973-3986)
- TM 11-6625-620-45-1 General Support and Depot Maintenance Manual: Test Set, Teletypewriter TS-799/USM-1 (Reprinted with basic C1)
- TM 11-6625-700-10 Operator's Manual: Digital Readout, Electronic Counter AN/USM-207 (NSN 6625-00-911-6368)

- TM 11-6625-1703-15 Operator's, Organizational, Direct Support, General Support, and Depot Maintenance Manual: Oscilloscope AN/USM-281A (NSN 6625-00-228-2201) (Reprinted with basic C1-2)
- TM 740-90-1 Administrative Storage of Equipment
- TM 750-244-2 Procedures for Destruction of Army Electronic Materiel to Prevent Enemy Use (Electronics Command)

A-5. MISCELLANEOUS PUBLICATIONS

- AR 385-11 Ionizing Radiation Protection (Licensing, Control, Transportation, Disposal, and Radiation Safety)
- DA PAM 310-1 Consolidated Index of Army Publications and Blank Forms
- DA PAM 738-750 The Army Maintenance Management System (TAMMS)
- SC 5180-91-CL-R07 Tool Kit, Electronic Equipment, TK-105/G (NSN 5180-00-610-8177) (LIN W37388)
- SC 5180-91-CL-S21 Tool Kit, Electronic Equipment, TK-100/G (NSN 5180-00-605-0079) (LIN W37251)

INDEX

SUBJECT	A	PARAGRAPH	PAGE
Abbreviations and reference designations		1-13	1-5
Adjustment procedures (introduction) (general instructions).....		2-13	2-33
BFO frequency limits		2-16	2-37
Loop current		2-15	2-35
Regulated voltage		2-14	2-34
Scope module A2 alignment		2-18	2-39
Scope module A2 centering		2-17	2-38
B			
Bench test setup		2-4	2-5
BFO frequency limits adjustment		2-16	2-37
Chassis components (removing and replacing)		3-9	3-24
Configurations, equipment		1-11	1-4
Current regulator		1-40	1-26
D			
Dc loop (receive).....		1-33	1-21
Dc loop (send).....		1-20	1-11
Dc to ac Inverter		1-40	1-26
Description and location of major components		1-9	1-4
Destruction of army materiel to prevent enemy use		1-4	1-3
Detailed block diagram analysis of receive signal paths (general)		1-27	1-18
Detailed block diagram analysis of scope module		1-37	1-23
Detailed block diagram analysis of transmit signal paths (general)		1-19	1-11
Differences in models		1-10	1-4
Direct support maintenance (introduction) (general)		2-1	2-1
Adjustment procedures (general instructions)		2-13	2-33
Test point measurements		2-7	2-24
Troubleshooting (general information)		2-3	2-4
Troubleshooting chart		2-6	2-8
Troubleshooting symptom Index		2-5	2-7
Diversity switching (detailed block diagram)		1-34	1-22
Diversity switching (stage analysis)		1-58	1-48
E			
85 Hz diversity operation		1-70	1-58
85 Hz operation		1-68	1-57
85 Hz + voice operation		1-71	1-58
850 Hz operation		1-67	1-56
Equipment configurations		1-11	1-4
F			
Forms (maintenance), records and reports		1-3	1-3
Frequency discriminator circuits		1-56	1-44
Front panel assembly (removing and replacing)		2-9	2-28
Front panel components (removing and replacing)		3-8	3-22

INDEX-Continued

SUBJECT	PARAGRAPH	PAGE
G		
General support maintenance (introduction)	3-1	3-1
Adjust procedures	3-10	3-25
Test point measurements	3-7	3-19
Troubleshooting (general information)	3-3	3-1
Troubleshooting chart	3-6	3-3
Troubleshooting symptom index	3-5	3-2
Intensity squelching	1-61	1-53
L		
Location and description of major components	1-9	1-4
Loop battery module	1-39	1-24
Loop current adjustment	2-15	2-35
M		
Maintenance forms, records and reports	1-3	1-3
Mark-hold switching	1-59	1-50
Mark-space oscillator output divider circuits	1-45	1-33
Mark-space oscillator output switching	1-44	1-33
Mark-space pulse generation	1-31	1-20
Mark-space tone generation	1-22	1-12
Metering and monitoring simplified circuits	1-18	1-10
Metering circuitry	1-73	1-59
Metering stage analysis and switching (general)	1-72	1-59
Mixer amplifier and transmit fsk/nsk filter switching	1-49	1-38
Mixer circuit	1-23	1-14
Mixer oscillator and switching	1-46	1-35
Mixer oscillator output divider circuits	1-47	1-36
Modules (removing and replacing)	2-8	2-27
O		
Operational control circuits	1-67	1-56
Output amplifying circuits	1-51	1-40
P		
Power input and transient suppressor stage analysis	1-64	1-54
Power supply.....	1-62	1-53
Power supply simplified block diagram	1-17	1-10
Power supply stage analysis and switching (general information)	1-63	1-54
Printed circuit boards (removing and replacing)	2-10	2-29
Purpose and use (of modem)	1-8	1-4
R		
Receive and send sensing circuit	1-41	1-28
Receive audio module	1-54	1-41
Receive dc loop	1-33	1-21
Receive input isolation amplifiers	1-53	1-40
Receive mark-space pulse generation	1-31	1-20
Receive mark-space pulse generation, stage analysis	1-57	1-46
Receive sensing circuit	1-32	1-20
Receive signal path, detailed block diagram	1-28	1-18

INDEX-Continued

SUBJECT	PARAGRAPH	PAGE
Receive signal path input	1-28	1-18
Receive signal path, simplified block diagram	1-16	1-7
Receive signal path, stage analysis (introduction)	1-52	1-40
Receive tty channel 1	1-30	1-19
Receive tty channel 2	1-29	1-19
Receiver module	1-55	1-42
Reference designations and abbreviations	1-13	1-5
Regulated voltage adjustment	2-14	2-34
Removing and replacing:		
Chassis components	3-9	3-24
Front panel assembly	2-9	2-28
Front panel components	3-8	3-22
Modules	2-8	2-27
Power transistors	2-11	2-29
Printed circuit boards	2-10	2-29
Repair parts, tools, test equipment, materials	2-2	2-1
Reporting equipment improvement recommendations	1-6	1-3
S		
Safety, care, and handling	1-12	1-4
Scope (introduction to manual)	1-1	1-3
Scope module	1-60	1-52
Scope module alignment adjustment	2-18	2-39
Scope module centering adjustment	2-17	2-38
Scope module, detailed block diagram	1-37	1-23
Send and receive sensing circuit	1-41	1-28
Send dc loop	1-20	1-11
Send sensing circuit	1-21	1-11
Signals produced in transmit signal path	1-26	1-18
Simplified metering and monitoring circuits	1-18	1-10
Sine wave pass filter, isolation amplifier and mixer	1-48	1-36
Stage analysis, receive signal path (introduction)	1-52	1-40
Stage analysis, transmit signal path (introduction)	1-38	1-24
Switching circuits	1-42	1-30
T		
Technical characteristics	1-7	1-3
Technical principles of operation (general information)	1-14	1-5
Test conditions and modem bench test setup	2-4	2-5
Test equipment, repair parts, tools, and material	2-2	2-1
Test point measurements (direct support)	2-7	2-24
Test point measurements (general support)	3-7	3-19
Transistors (removal and replacing)	2-11	2-29
Transmit output circuitry	1-25	1-16
Transmit signal path, detailed block diagram (general information)	1-19	1-11
Transmit signal path, signals produced	1-26	1-18
Transmit signal path, simplified block diagram	1-15	1-7
Transmit signal path, stage analysis (introduction)	1-38	1-24
Transmit voice circuits	1-50	1-39
Transmit voice signal path	1-24	1-15
Transmitter module	1-43	1-32

INDEX-Continued

SUBJECT	PARAGRAPH	PAGE
Troubleshooting chart (direct support)	2-6	2-8
Troubleshooting chart (general support)	3-6	3-3
Tty squelch (mark-hold) switching	1-35	1-22
Twenty volt regulator	1-66	1-55
Twenty-two volt preregulator	1-65	1-55
V		
Voice and tty monitor signal path	1-36	1-23
Voice operation	1-69	1-57

By Order of the Secretary of the Army:

Official:

JOHN A. WICKHAM JR.
General, United States Army
Chief of Staff

ROBERT M. JOYCE
Major General, United States Army
The Adjutant General

DISTRIBUTION:

To be distributed in accordance with DA Form 12-51 requirements for MD-522/GRC.

FOLDOUT INDEX

Figure FO-1	MIL-STD Resistor, Capacitor, and Inductor Color Code Markings
Figure FO-2	Connection of Modem, Radio Teletypewriter MD-522A/GRC to Typical Equipment
Figure FO-3	Receiver Signal Path, Simplified Block Diagram
Figure FO-4	Transmit Signal Path, Detailed Block Diagram
Figure FO-5	Receive Signal Path, Detailed Block Diagram
Figure FO-6	Receive Signal Path (Continued), Detailed Block Diagram
Figure FO-7	Scope A2 Module, Block Diagram
Figure FO-8	MD-522A/GRC Main Chassis, Overall Schematic Diagram
Figure FO-9	Loop Battery A5 Module, Schematic Diagram
Figure FO-10	Transmitter A3 Module, Schematic Diagram
Figure FO-11	Transmit Voice, Circuits, Simplified Schematic Diagram
Figure FO-12	Receive Audio A1 Module, Schematic Diagram
Figure FO-13	Receive A4 Module, Schematic Diagram
Figure FO-14	Scope A2 Module, Schematic Diagram
Figure FO-15	Main Power Supply, Control and Protective Circuits, Simplified Schematic Diagram

☆U. S. GOVERNMENT PRINTING OFFICE 1993 - 342-421 / 62012

F.O. INDEX-1/(F.O. INDEX-2, blank)

RECOMMENDED CHANGES TO EQUIPMENT TECHNICAL PUBLICATIONS

 <p style="text-align: center;"><i>THEN...JOT DOWN THE DOPE ABOUT IT ON THIS FORM. CAREFULLY TEAR IT OUT, FOLD IT AND DROP IT IN THE MAIL.</i></p>		SOMETHING WRONG WITH PUBLICATION	
		FROM: (PRINT YOUR UNIT'S COMPLETE ADDRESS)	
		DATE SENT	
PUBLICATION NUMBER		PUBLICATION DATE	PUBLICATION TITLE
BE EXACT PIN-POINT WHERE IT IS			
PAGE NO.	PARA-GRAPH	FIGURE NO.	TABLE NO.
<div style="text-align: center; font-weight: bold; margin-bottom: 10px;">IN THIS SPACE, TELL WHAT IS WRONG AND WHAT SHOULD BE DONE ABOUT IT.</div> <div style="border: 1px dashed black; height: 400px; width: 100%;"></div>			
PRINTED NAME, GRADE OR TITLE AND TELEPHONE NUMBER			SIGN HERE

The Metric System and Equivalents

Linear Measure

1 centimeter = 10 millimeters = .39 inch
 1 decimeter = 10 centimeters = 3.94 inches
 1 meter = 10 decimeters = 39.37 inches
 1 dekameter = 10 meters = 32.8 feet
 1 hectometer = 10 dekameters = 328.08 feet
 1 kilometer = 10 hectometers = 3,280.8 feet

Weights

1 centigram = 10 milligrams = .15 grain
 1 decigram = 10 centigrams = 1.54 grains
 1 gram = 10 decigrams = .035 ounce
 1 decagram = 10 grams = .35 ounce
 1 hectogram = 10 decagrams = 3.52 ounces
 1 kilogram = 10 hectograms = 2.2 pounds
 1 quintal = 100 kilograms = 220.46 pounds
 1 metric ton = 10 quintals = 1.1 short tons

Liquid Measure

1 centiliter = 10 milliliters = .34 fl. ounce
 1 deciliter = 10 centiliters = 3.38 fl. ounces
 1 liter = 10 deciliters = 33.81 fl. ounces
 1 dekaliter = 10 liters = 2.64 gallons
 1 hectoliter = 10 dekaliters = 26.42 gallons
 1 kiloliter = 10 hectoliters = 264.18 gallons

Square Measure

1 sq. centimeter = 100 sq. millimeters = .155 sq. inch
 1 sq. decimeter = 100 sq. centimeters = 15.5 sq. inches
 1 sq. meter (centare) = 100 sq. decimeters = 10.76 sq. feet
 1 sq. dekameter (are) = 100 sq. meters = 1,076.4 sq. feet
 1 sq. hectometer (hectare) = 100 sq. dekameters = 2.47 acres
 1 sq. kilometer = 100 sq. hectometers = .386 sq. mile

Cubic Measure

1 cu. centimeter = 1000 cu. millimeters = .06 cu. inch
 1 cu. decimeter = 1000 cu. centimeters = 61.02 cu. inches
 1 cu. meter = 1000 cu. decimeters = 35.31 cu. feet

Approximate Conversion Factors

<i>To change</i>	<i>To</i>	<i>Multiply by</i>	<i>To change</i>	<i>To</i>	<i>Multiply by</i>
inches	centimeters	2.540	ounce-inches	Newton-meters	.007062
feet	meters	.305	centimeters	inches	.394
yards	meters	.914	meters	feet	3.280
miles	kilometers	1.609	meters	yards	1.094
square inches	square centimeters	6.451	kilometers	miles	.621
square feet	square meters	.093	square centimeters	square inches	.155
square yards	square meters	.836	square meters	square feet	10.764
square miles	square kilometers	2.590	square meters	square yards	1.196
acres	square hectometers	.405	square kilometers	square miles	.386
cubic feet	cubic meters	.028	square hectometers	acres	2.471
cubic yards	cubic meters	.765	cubic meters	cubic feet	35.315
fluid ounces	milliliters	29.573	cubic meters	cubic yards	1.308
pints	liters	.473	milliliters	fluid ounces	.034
quarts	liters	.946	liters	pints	2.113
gallons	liters	3.785	liters	quarts	1.057
ounces	grams	28.349	liters	gallons	.264
pounds	kilograms	.454	grams	ounces	.035
short tons	metric tons	.907	kilograms	pounds	2.205
pound-feet	Newton-meters	1.356	metric tons	short tons	1.102
pound-inches	Newton-meters	.11296			

Temperature (Exact)

°F	Fahrenheit temperature	5/9 (after subtracting 32)	Celsius temperature	°C
----	---------------------------	-------------------------------	------------------------	----

PIN: 055597-000

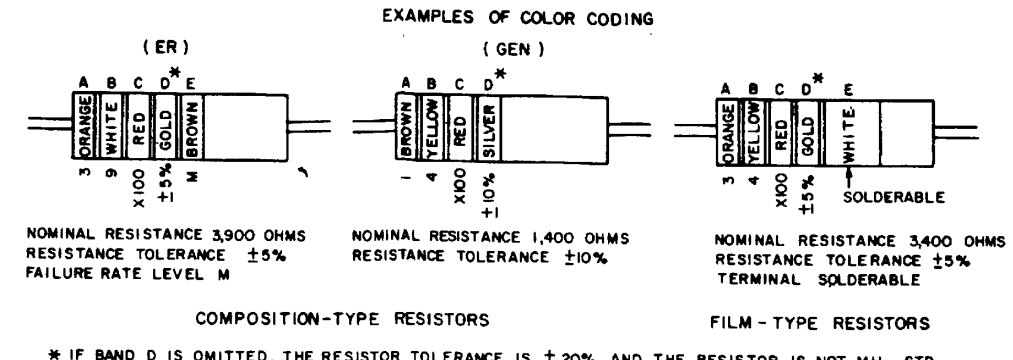
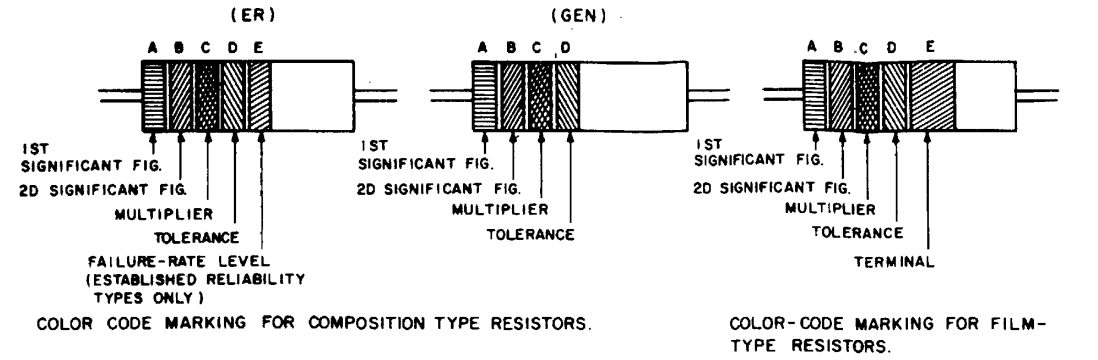

* IF BAND D IS OMITTED, THE RESISTOR TOLERANCE IS ±20% AND THE RESISTOR IS NOT MIL-STD.

TABLE 1
COLOR CODE FOR COMPOSITION TYPE AND FILM TYPE RESISTORS.

BAND A		BAND B		BAND C		BAND D		BAND E		
COLOR	FIRST SIGNIFICANT FIGURE	COLOR	SECOND SIGNIFICANT FIGURE	COLOR	MULTIPLIER	COLOR	RESISTANCE TOLERANCE (PERCENT)	COLOR	FAILURE RATE LEVEL	TERM.
BLACK	0	BLACK	0	BLACK	1			BROWN	M=1.0	
BROWN	1	BROWN	1	BROWN	10			RED	P=0.1	
RED	2	RED	2	RED	100			ORANGE	R=0.01	
ORANGE	3	ORANGE	3	ORANGE	1,000	SILVER	±10 (COMP. TYPE ONLY)	YELLOW	S=0.001	SOLDERABLE
YELLOW	4	YELLOW	4	YELLOW	10,000			WHITE		
GREEN	5	GREEN	5	GREEN	100,000	GOLD	±5			
BLUE	6	BLUE	6	BLUE	1,000,000	RED	±2 (NOT APPLICABLE TO ESTABLISHED RELIABILITY).			
PURPLE (VIOLET)	7	PURPLE (VIOLET)	7							
GRAY	8	GRAY	8	SILVER	0.01					
WHITE	9	WHITE	9	GOLD	0.1					

BAND A — THE FIRST SIGNIFICANT FIGURE OF THE RESISTANCE VALUE (BANDS A THRU D SHALL BE OF EQUAL WIDTH.)

BAND B — THE SECOND SIGNIFICANT FIGURE OF THE RESISTANCE VALUE.

BAND C — THE MULTIPLIER (THE MULTIPLIER IS THE FACTOR BY WHICH THE TWO SIGNIFICANT FIGURES ARE MULTIPLIED TO YIELD THE NOMINAL RESISTANCE VALUE.)

BAND D — THE RESISTANCE TOLERANCE.

BAND E — WHEN USED ON COMPOSITION RESISTORS, BAND E INDICATES ESTABLISHED RELIABILITY FAILURE-RATE LEVEL (PERCENT FAILURE PER 1,000 HOURS). ON FILM RESISTORS, THIS BAND SHALL BE APPROXIMATELY 1-1/2 TIMES THE WIDTH OF OTHER BANDS, AND INDICATES TYPE OF TERMINAL.

RESISTANCES IDENTIFIED BY NUMBERS AND LETTERS (THESE ARE NOT COLOR CODED)

SOME RESISTORS ARE IDENTIFIED BY THREE OR FOUR DIGIT ALPHA NUMERIC DESIGNATORS. THE LETTER R IS USED IN PLACE OF A DECIMAL POINT WHEN FRACTIONAL VALUES OF AN OHM ARE EXPRESSED. FOR EXAMPLE:

2R7 = 2.7 OHMS 10R0 = 10.0 OHMS

FOR WIRE-WOUND-TYPE RESISTORS COLOR CODING IS NOT USED, IDENTIFICATION MARKING IS SPECIFIED IN EACH OF THE APPLICABLE SPECIFICATIONS.

A. COLOR CODE MARKING FOR MILITARY STANDARD RESISTORS.

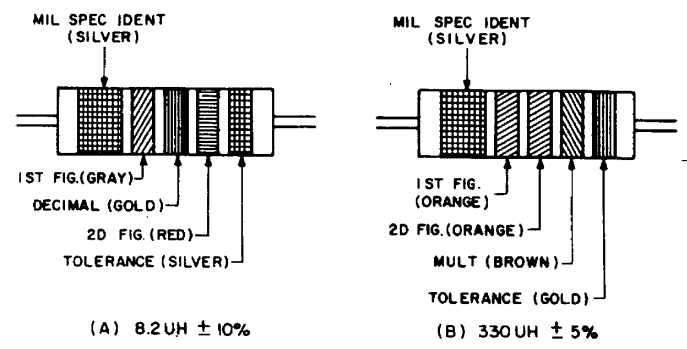

COLOR CODING FOR TUBULAR ENCAPSULATED R.F. CHOKES. AT A, AN EXAMPLE OF OF THE CODING FOR AN 8.2UH CHOKE IS GIVEN. AT B, THE COLOR BANDS FOR A 330UH INDUCTOR ARE ILLUSTRATED.

TABLE 2
COLOR CODING FOR TUBULAR ENCAPSULATED R.F. CHOKES.

COLOR	SIGNIFICANT FIGURE	MULTIPLIER	INDUCTANCE TOLERANCE (PERCENT)
BLACK	0	1	
BROWN	1	10	1
RED	2	100	2
ORANGE	3	1,000	3
YELLOW	4		
GREEN	5		
BLUE	6		
VIOLET	7		
GRAY	8		
WHITE	9		
NONE			20
SILVER			10
GOLD	DECIMAL POINT		5

MULTIPLIER IS THE FACTOR BY WHICH THE TWO COLOR FIGURES ARE MULTIPLIED TO OBTAIN THE INDUCTANCE VALUE OF THE CHOKE COIL.

B. COLOR CODE MARKING FOR MILITARY STANDARD INDUCTORS.

Figure F0-1 Color Code Marking for Military Standard Resistors and Inductors, Sheet 1 of 2

CAPACITOR COLOR CODE TABLES

TABLE I - For use with Group I, Styles CM, CN, CY and CB

COLOR	MIL ID	1st SIG FIG	2nd SIG FIG	MULTIPLIER ¹	CAPACITANCE TOLERANCE				CHARACTERISTIC ¹				DC WORKING VOLTAGE	OPERATING TEMP. RANGE	VIBRATION GRADE
					CM	CN	CY	CB	CM	CN	CY	CB	CM	CM	CM
BLACK	CM, CY CB	0	0	1					± 20%	± 20%	A			55 ° to + 70 °C	10 - 55 cps
BROWN		1	1	10							B	E			
RED		2	2	100	± 2%				± 2%	± 2%	C		C		
ORANGE		3	3	1,000		± 30%					D			300	
YELLOW		4	4	10,000							E		D		-55 ° to + 125 °C 10 - 200 cps
GREEN		5	5			± 5%					F			500	
BLUE		6	6												-55 ° to + 150 °C
PURPLE (VIOLET)		7	7												
GREY		8	8												
WHITE		9	9												
GOLD				0.1					± 5%	± 5%					
SILVER	CN				± 10%	± 10%			± 10%	± 10%					

TABLE II - For use with Group II, General Purposes, Style CK

COLOR	TEMP. RANGE AND VOLTAGE - TEMP LIMITS ¹	1st SIG FIG	2nd SIG FIG	MULTIPLIER ¹	CAPACITANCE TOLERANCE	MIL ID
BLACK		0	0	1	± 20%	
BROWN	AW	1	1	10	± 10%	
RED	AX	2	2	100		
ORANGE	BX	3	3	1,000		
YELLOW	AV	4	4	10,000		CK
GREEN	CZ	5	5			
BLUE	BV	6	6			
PURPLE (VIOLET)		7	7			
GREY		8	8			
WHITE		9	9			
GOLD						
SILVER						

TABLE III - For use with Group III, Temperature Compensating, Style CC

COLOR	TEMPERATURE COEFFICIENT	1st SIG FIG	2nd SIG FIG	MULTIPLIER ¹	CAPACITANCE TOLERANCE		MIL ID
					CAPACITANCES OVER 10uuf	CAPACITANCES 10uuf OR LESS	
BLACK	0	0	0	1		± 2.0uuf	CC
BROWN	-30	1	1	10		± 1%	
RED	-80	2	2	100		± 2%	
ORANGE	-150	3	3	1,000		± 0.25uuf	
YELLOW	-220	4	4				
GREEN	-330	5	5			± 5%	± 0.5uuf
BLUE	-470	6	6				
PURPLE (VIOLET)	-750	7	7	0.01			
GREY		8	8	0.1		± 10%	
WHITE		9	9				
GOLD	+100						± 1.0uuf
SILVER							

- The multiplier is the number by which the two significant (SIG) figures are multiplied to obtain the capacitance in uuf.
- Letter indicate the Characteristics designated in applicable specifications: MIL-C-5, MIL-C-9, MIL-C-11272, and MIL-C-10950 respectively.
- Letters indicate the temperature range and voltage-temperature limits designated in MIL-C-11015.
- Temperature coefficient in parts per million per degree centigrade.

COLOR CODE MARKING FOR MILITARY STANDARD CAPACITORS

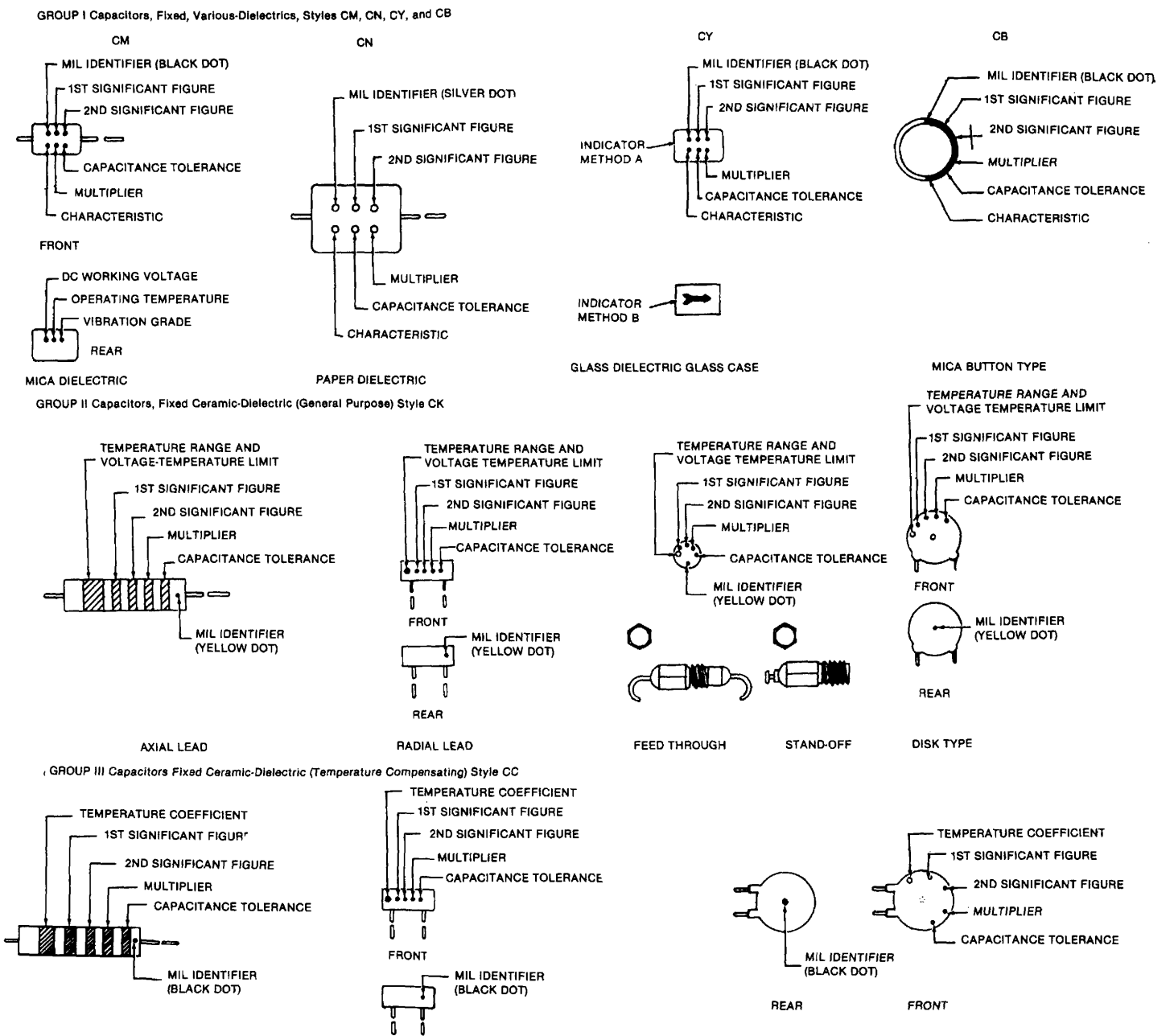
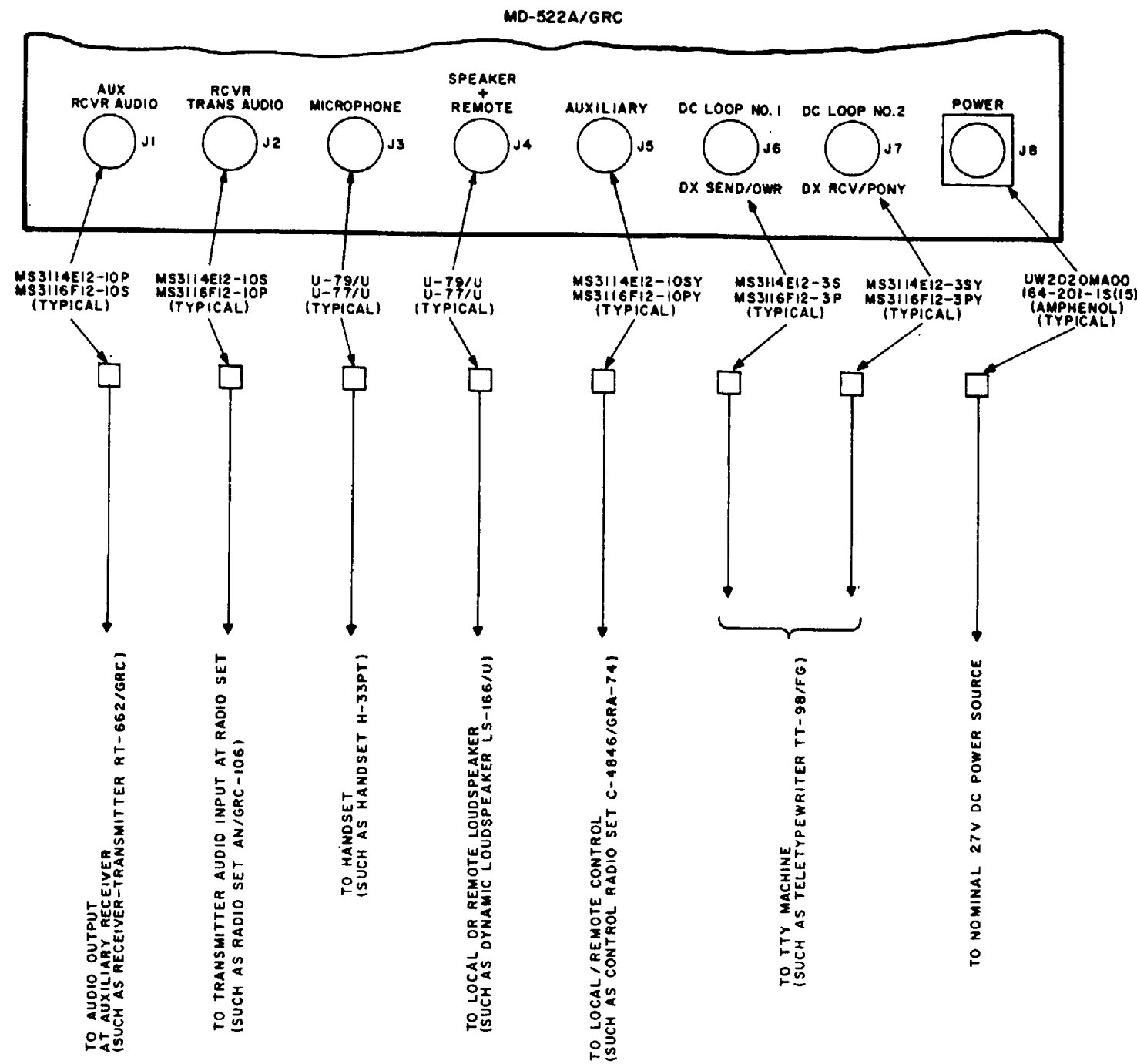

Figure F0-1 Color Code Marking for Military Standard Resistors and Inductors, Sheet 2 of 2



REF DESIG	PIN	CONNECTION
J1	A	FROM AUX RECEIVER AUDIO
	B	GROUND
	C	SPARE
	D	SPARE
	E	GROUND
	F	SPARE
	G	SPARE
	H	GROUND
	J	SPARE
	K	SPARE
	J2	A
B		GROUND
C		TO RECEIVER-TRANSMITTER 50 OHM MICROPHONE INPUT
D		COMMON FOR PINS C AND J
E		GROUND
F		RECEIVER-TRANSMITTER KEYLINE
G		SPARE
H		GROUND
J		TO RECEIVER-TRANSMITTER 600 OHM INPUT
K		COMMON BUSS TO PIN K ON J3 AND J4
J3		A
	B	GROUND
	C	50 OHM MICROPHONE INPUT
	D	SPARE
	E	MICROPHONE RETURN
	F	RECEIVER-TRANSMITTER KEYLINE
J4	H	GROUND
	J	600 OHM AUDIO INPUT
	K	COMMON BUSS TO PIN K ON J2 AND J4
	L	SPARE

REF DESIG	PIN	CONNECTION	
J4	A	10 MW OUTPUT TO HEADPHONES	
	B	GROUND	
	C	50 OHM MICROPHONE INPUT	
	D	SPARE	
	E	GROUND	
	F	RECEIVER-TRANSMITTER KEYLINE	
	H	GROUND	
	J	600 OHM AUDIO INPUT	
	K	COMMON BUSS TO PIN K ON J2 AND J3	
	L	2-WATT OUTPUT TO SPEAKER	
	J5	A	REMOTE ONE WAY-DUPLEX SWITCH
		B	GROUND
C		AUX PRIMARY POWER SOURCE (NOMINAL +27 VDC UNFUSED)	
D		RECEIVER-TRANSMITTER KEYLINE	
E		REMOTE SEND-RCV SWITCH	
F		SPARE	
G		SPARE	
H		SPARE	
J		SPARE	
K		SPARE	
J6		A	DC LOOP NO.1 POSITIVE SIDE (INTERNAL SUPPLY)
	B	GROUND	
	C	DC LOOP NO.1 NEGATIVE SIDE (INTERNAL SUPPLY)	
J7	A	DC LOOP NO.2 POSITIVE SIDE (INTERNAL SUPPLY)	
	B	GROUND	
	C	DC LOOP NO.2 NEGATIVE SIDE (INTERNAL SUPPLY)	
J8	A	+27 VDC NOMINAL	
	B	+27 VDC NOMINAL	
	C	GROUND	
	D	GROUND	

Figure F0-2. Connection of Modem, Radio Teletypewriter MD-522A/GRC to Typical Equipment

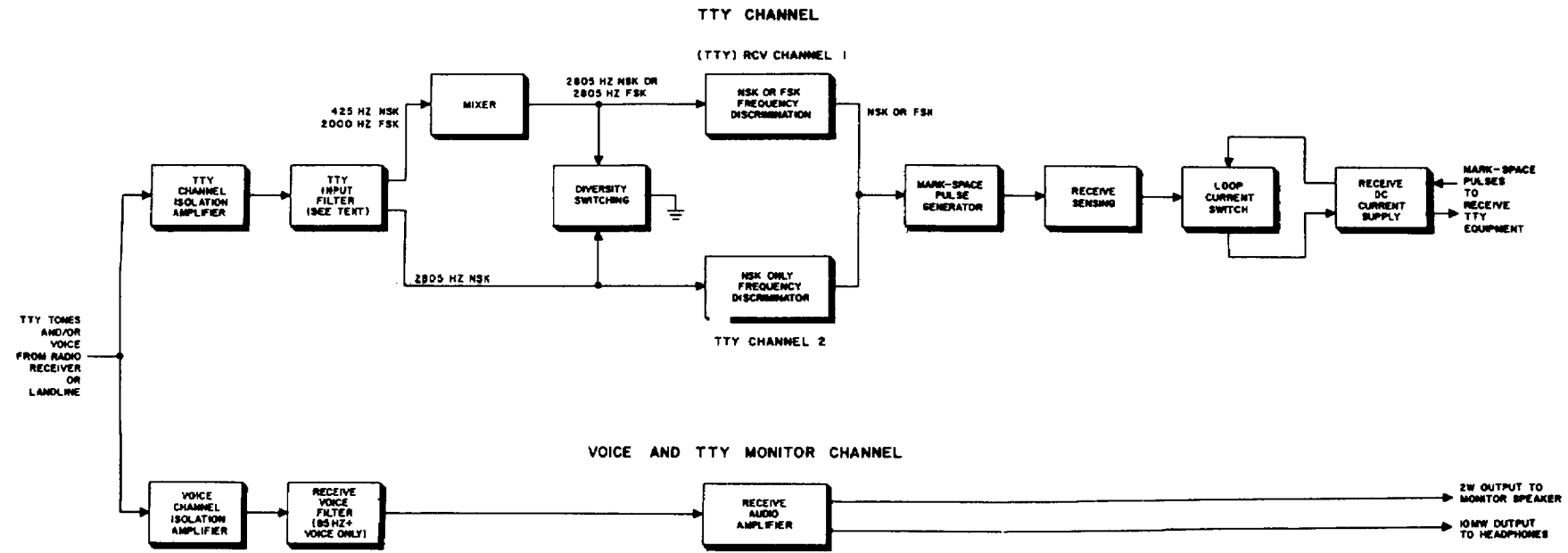

Figure F0-3. Receiver Signal Path, Simplified Block Diagram

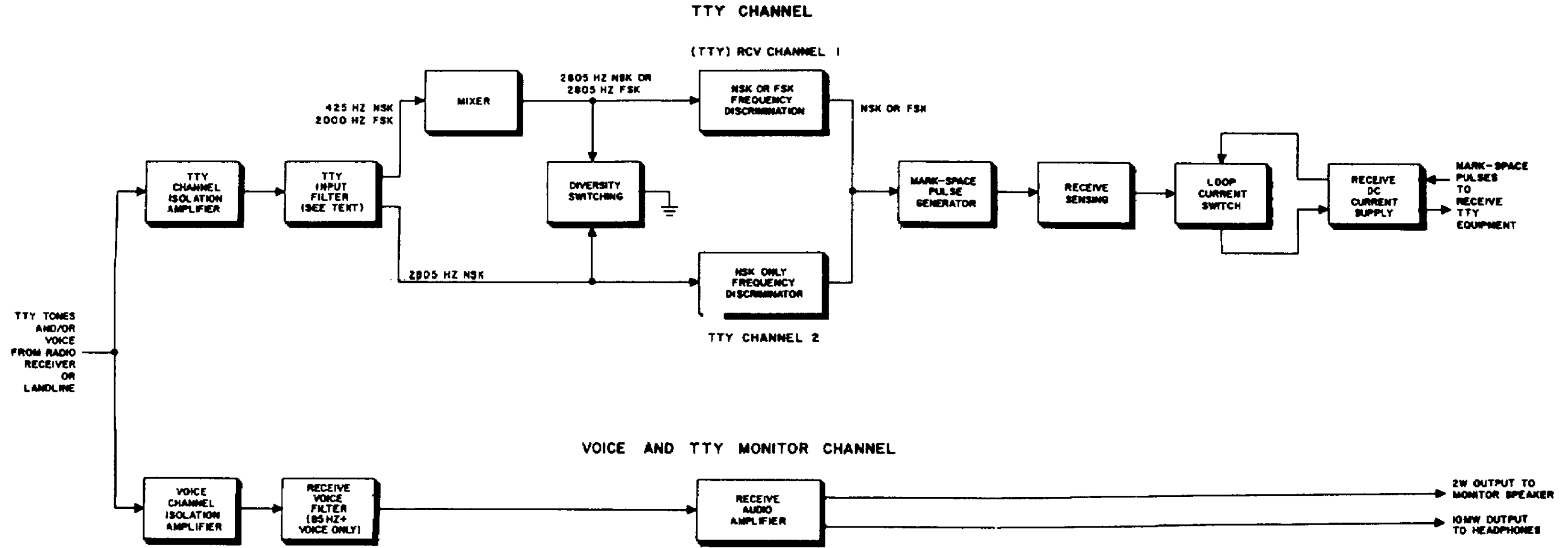

Figure F0-4. Transmit Signal Path, Detailed Block Diagram

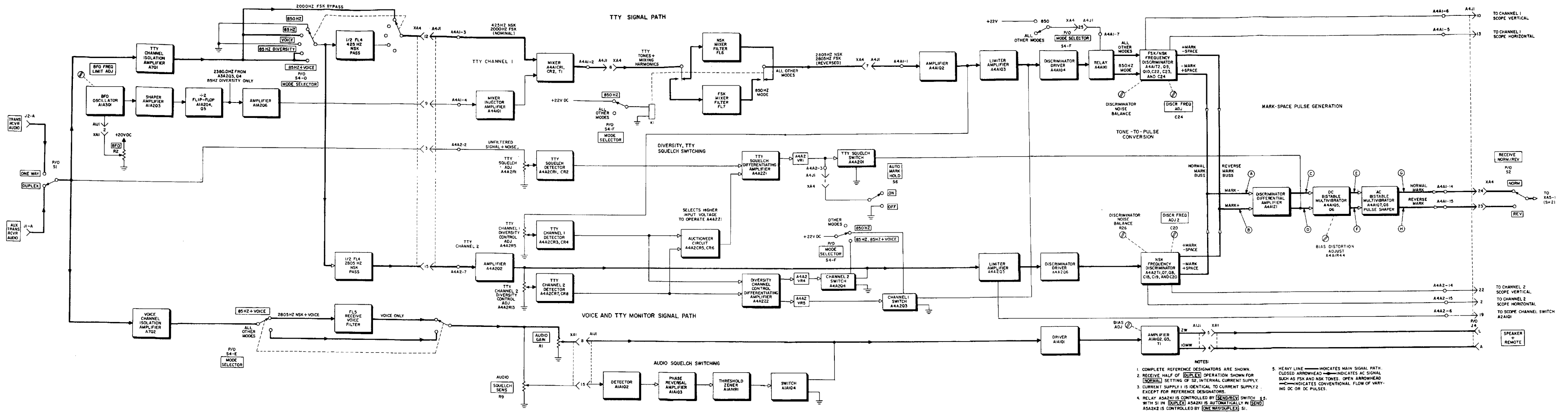

Figure F0-5. Receive Signal Path, Detailed Block Diagram

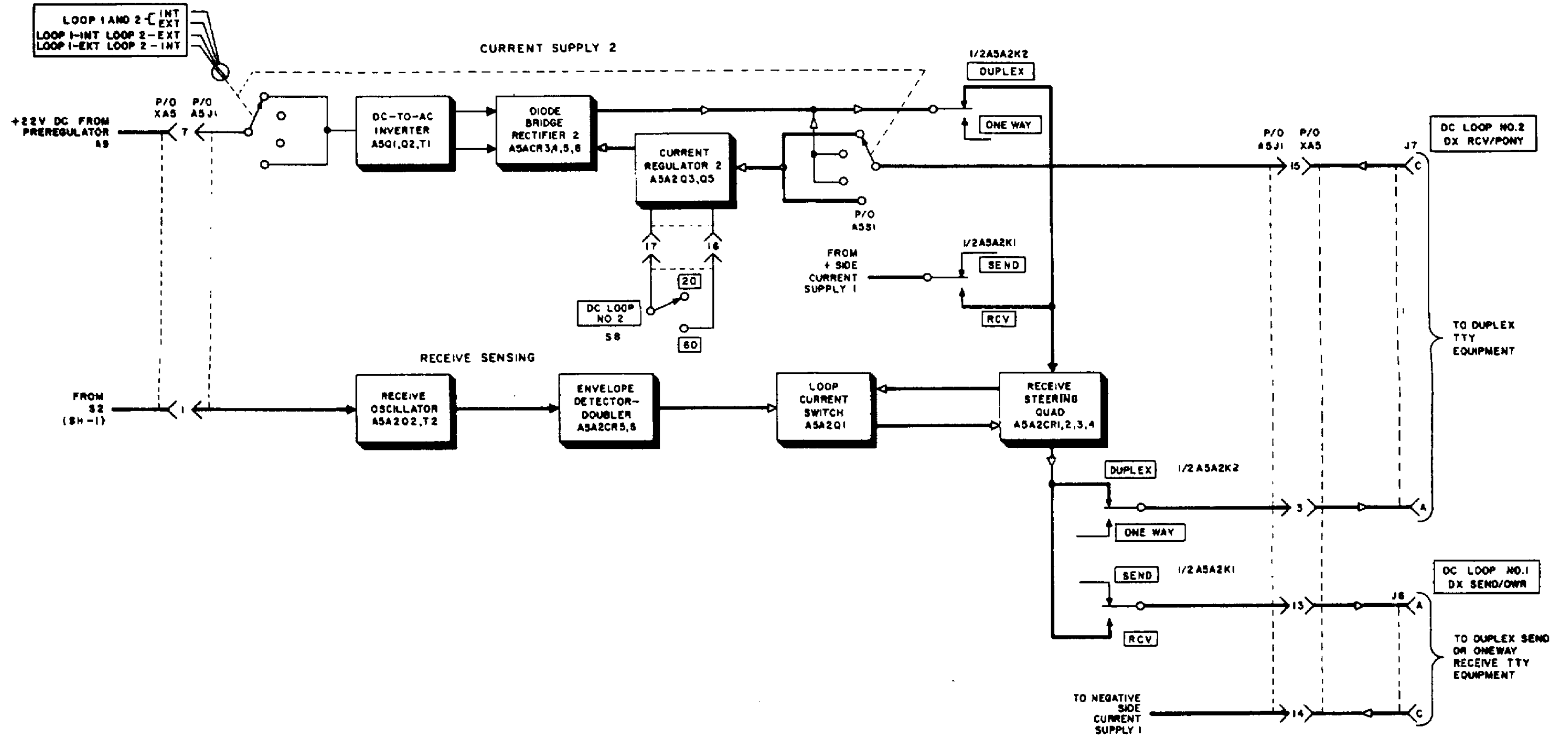

Figure F0-6. Receive Signal Path (Continued), Block Diagram

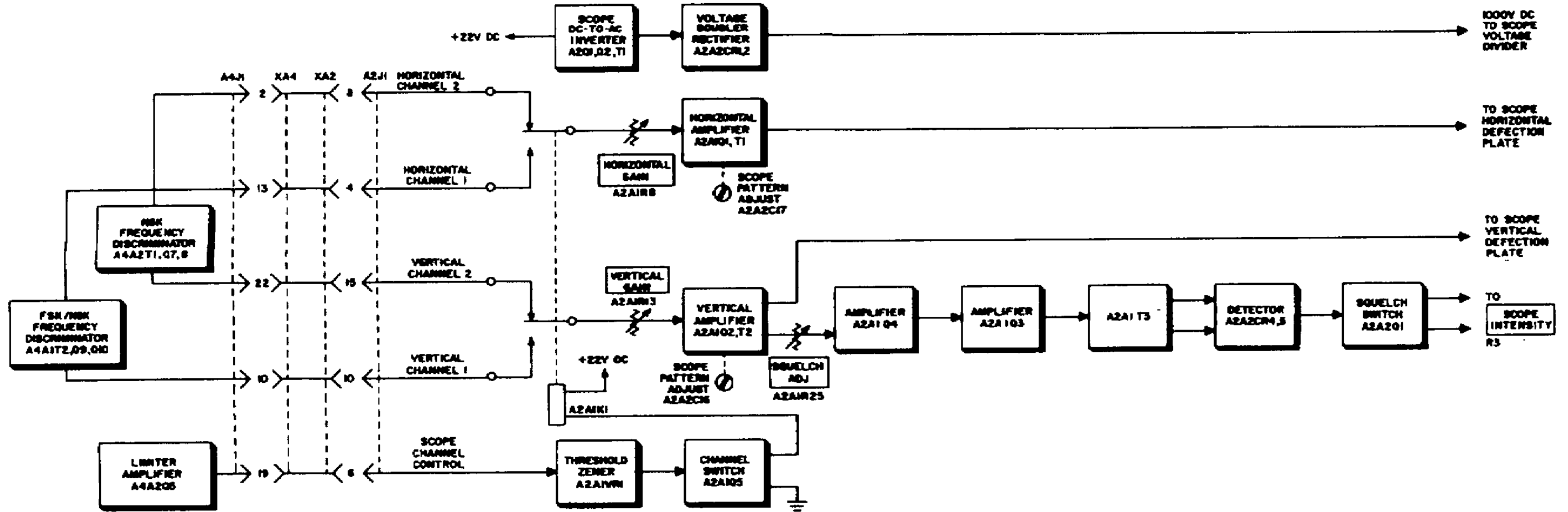
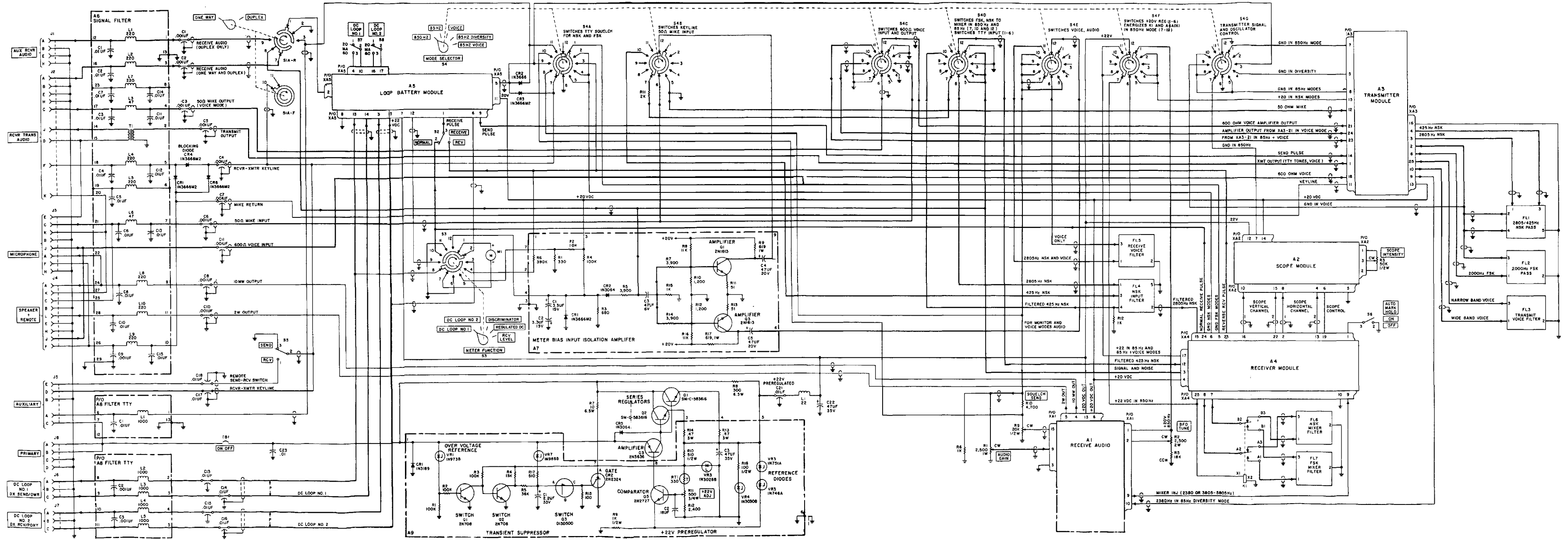
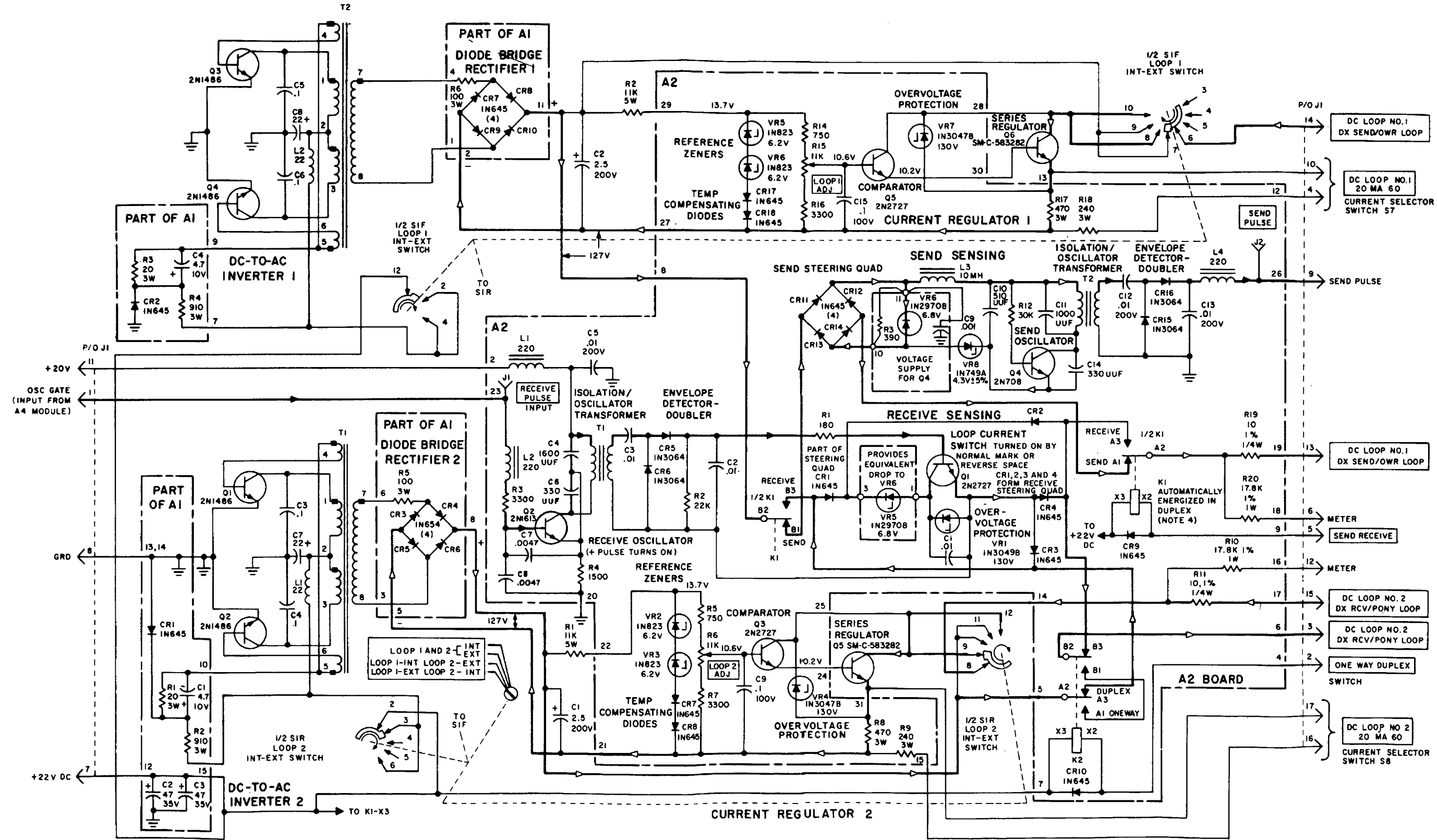

Figure F0-7. Scope A2 Module, Block Diagram



- NOTES:**
- PARTIAL REFERENCE DESIGNATIONS ARE SHOWN. FOR COMPLETE DESIGNATION, PREFIX WITH UNIT NUMBER OR SUBASSEMBLY DESIGNATION(S).
 - UNLESS OTHERWISE SPECIFIED:
 ALL RESISTANCE VALUES ARE IN OHMS.
 ALL RESISTOR RATINGS ARE 1/4 W.
 ALL RESISTOR TOLERANCES ARE ±5%.
 ALL CAPACITANCE VALUES ARE IN UUF.
 ALL INDUCTANCE VALUES ARE IN MICRO-HENRIES.
 - MAIN SIGNAL FLOW IS INDICATED BY A HEAVY LINE AND ARROWHEAD→.

Figure FO-8. MD-522A/GRC Main Chassis, Overall Schematic Diagram.



- NOTES:
- 1 ALL RESISTOR VALUES ARE IN OHMS, CAPACITORS IN UF, AND INDUCTORS IN UH UNLESS OTHERWISE SPECIFIED
 - 2 ALL SWITCHES ARE SHOWN IN CCW POSITION
 - 3 HEAVY LINES SHOW MAIN SIGNAL PATH FOR DUPLEX OPERATION, USING INTERNAL 20 MA SUPPLY. DC FLOW IS FROM + TO -, AND IS SHOWN BY AN OPEN ARROWHEAD; ▽ DIRECTION OF SEND AND RECEIVE PULSES ARE SHOWN BY A CLOSED ARROWHEAD. ▾
 - 4 KI IS SHOWN IN THE ENERGIZED POSITION
 - 5 VOLTAGE TOLERANCE OF ZENERS WITH "B" SUFFIX IS ± 5%, WITH NO SUFFIX. ± 10%

Figure FO-9. Loop Battery A5 Module, Schematic Diagram.

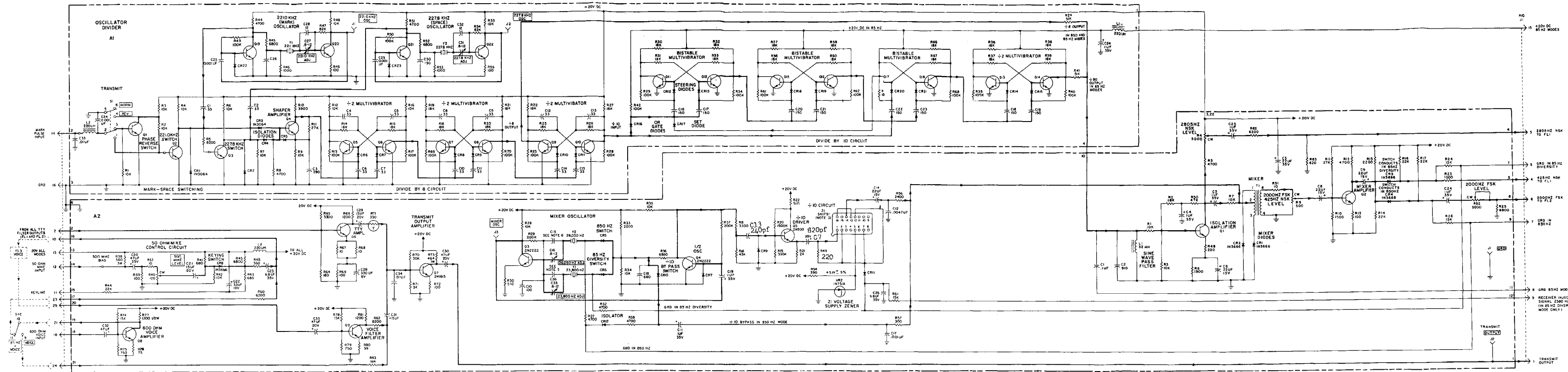

- NOTES:
- 1 FOR COMPLETE REFERENCE DESIGNATOR PREFIX PARTIAL REFERENCE DESIGNATORS WITH SUBASSEMBLY DESIGNATOR AND TRANSMITTER MODULE DESIGNATOR A5
 - 2 UNLESS OTHERWISE SPECIFIED, RESISTOR VALUES ARE IN OHMS, CAPACITORS IN MICROFARADS, INDUCTORS IN MICROHENRIES, TRANSISTORS ARE 2N708A, AND DIODES IN3064
 - 3 SN1791 IS A MONOLITHIC DECADE COUNTER CONSISTING OF FOUR INTERNALLY GATED AND INTERCONNECTED DUAL-RANK MASTER-SLAVE FLIP-FLOPS, CONNECTED TO DIVIDE INPUT FREQUENCY BY 10
 - 4 MAIN SIGNAL FLOW IN INDICATED BY A HEAVY LINE AND ARROWHEAD
 - 5 C36 MAY BE 12 OR 20 UF, SELECTION IS MADE TO ALLOW PROPER ADJUSTMENT OF Y1.
 - 6 C15 MAY BE 12 OR 20 UF, SELECTION IS MADE TO ALLOW PROPER ADJUSTMENT OF Y2.

Figure FO-10. Transmitter A3 Module, Schematic Diagram.

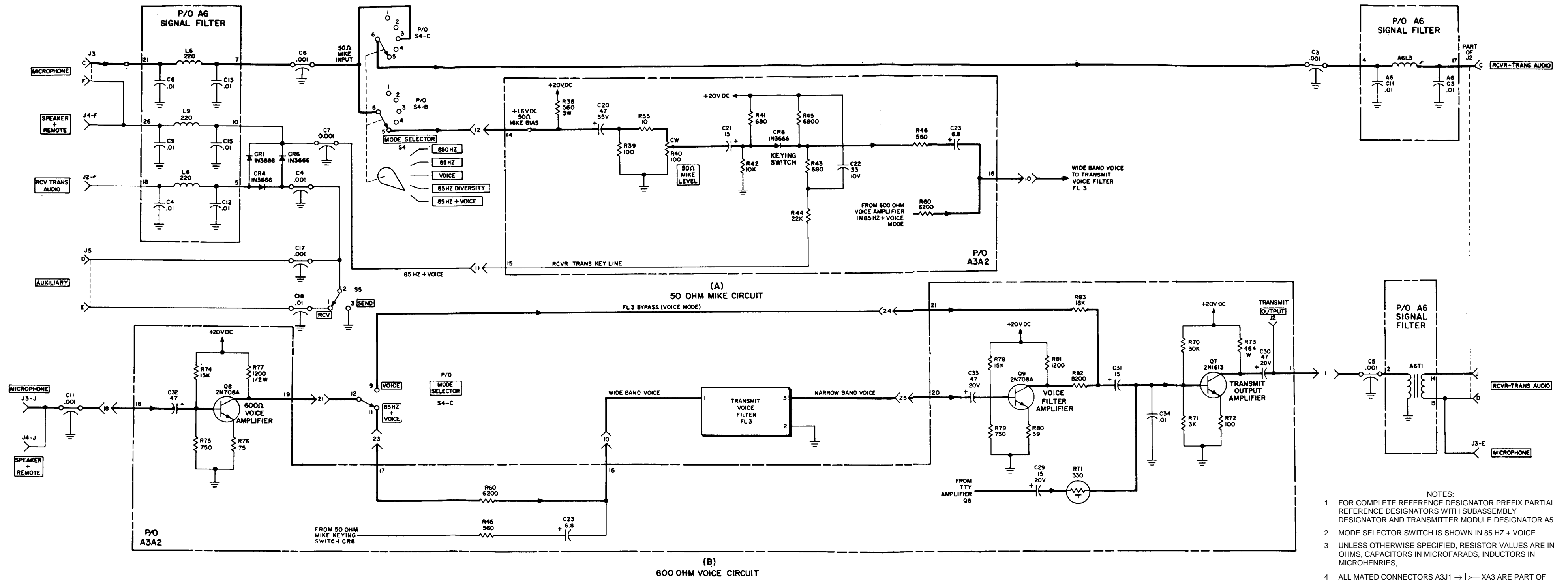
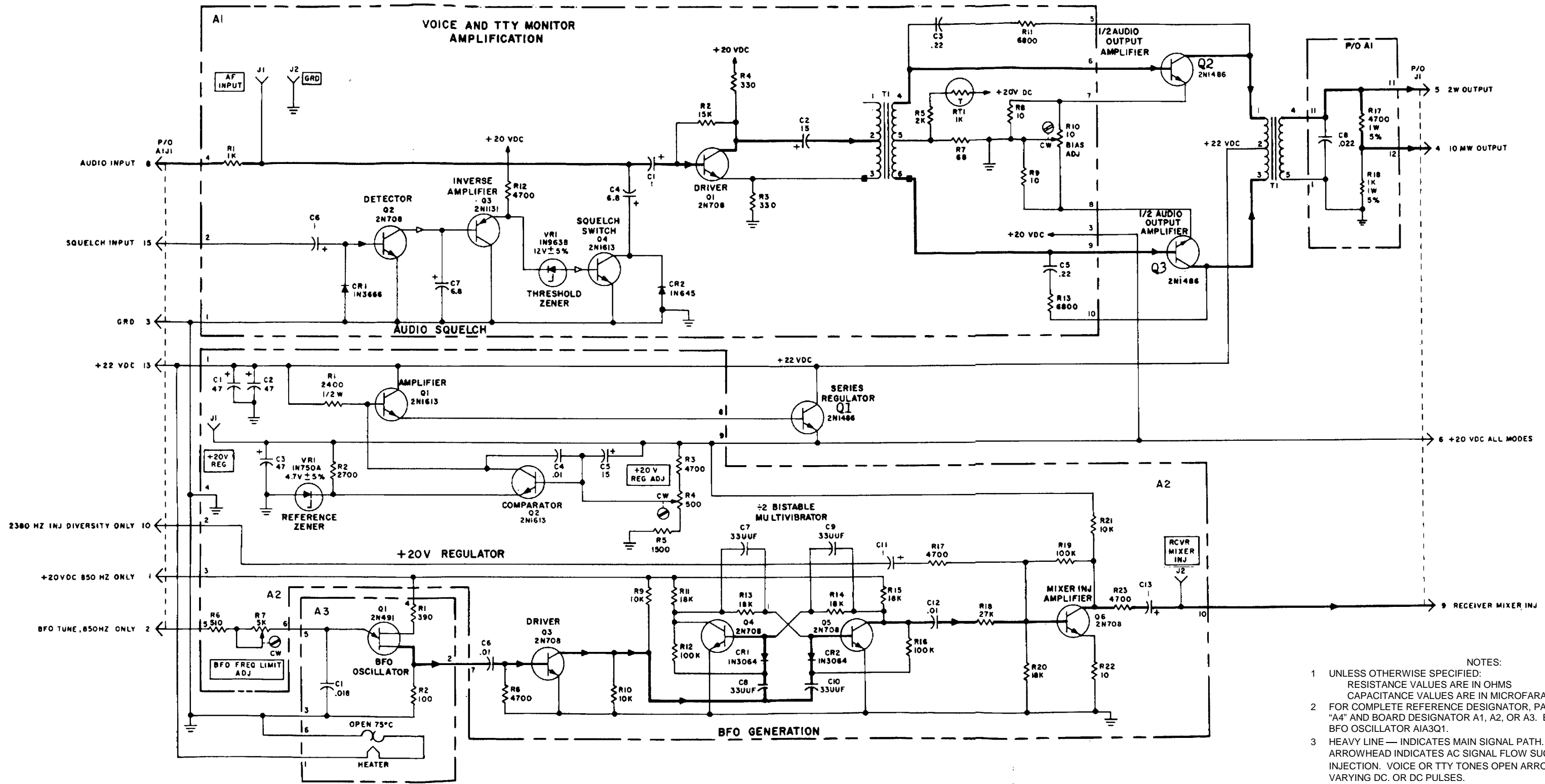

Figure FO-11. Transmit Voice Circuits, Simplified Schematic Diagram.

- NOTES:
- 1 FOR COMPLETE REFERENCE DESIGNATOR PREFIX PARTIAL REFERENCE DESIGNATORS WITH SUBASSEMBLY DESIGNATOR AND TRANSMITTER MODULE DESIGNATOR A5
 - 2 MODE SELECTOR SWITCH IS SHOWN IN 85 HZ + VOICE.
 - 3 UNLESS OTHERWISE SPECIFIED, RESISTOR VALUES ARE IN OHMS. CAPACITORS IN MICROFARADS, INDUCTORS IN MICROHENRIES.
 - 4 ALL MATED CONNECTORS A3J1 → | → XA3 ARE PART OF TRANSMITTER MODULE
 - 5 MAIN SIGNAL FLOW IS INDICATED BY A HEAVY LINE AND A CLOSED ARROWHEAD →
 DC MIKE BIAS IS SHOWN BY OPEN ARROWHEAD ↗



- NOTES:
- UNLESS OTHERWISE SPECIFIED:
RESISTANCE VALUES ARE IN OHMS
CAPACITANCE VALUES ARE IN MICROFARADS
 - FOR COMPLETE REFERENCE DESIGNATOR, PARTS DESIGNATOR WITH "A4" AND BOARD DESIGNATOR A1, A2, OR A3. EXAMPLE:
BFO OSCILLATOR A1A3Q1.
 - HEAVY LINE — INDICATES MAIN SIGNAL PATH. CLOSED →
ARROWHEAD INDICATES AC SIGNAL FLOW SUCH AS BFO MIXER INJECTION. VOICE OR TTY TONES OPEN ARROWHEAD ⇒ INDICATES VARYING DC. OR DC PULSES.

Figure FO-12. Receive Audio A1 Module, Schematic Diagram.

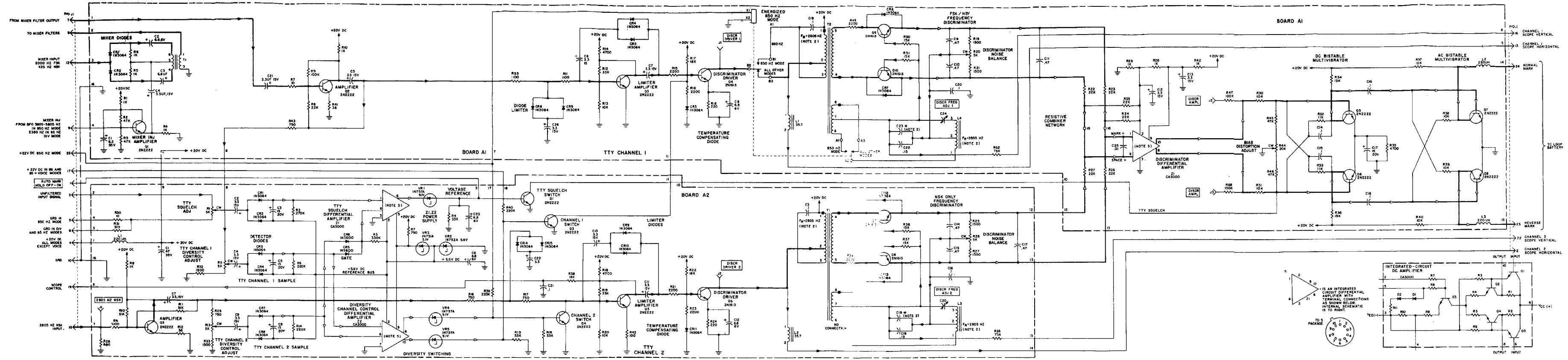

- NOTES:
- UNLESS OTHERWISE SPECIFIED:
RESISTANCE VALUES ARE IN OHMS
CAPACITANCE VALUES ARE IN MICROFARADS
INDUCTANCE VALUES ARE IN MILLI HENRIES,
ZENER TOLERANCE 5% FOR "A" SUFFIX,
(EXAMPLE: IN755A), 10% FOR ALL OTHERS
 - CAPACITORS MARKED * ARE FACTORY SELECTED TO PROVIDE A
RESONANT FREQUENCY (F_R) OF 2805 HZ
 - FOR COMPLETE REFERENCE DESIGNATOR PREFIX PARTS DESIGNATOR
WITH "A4" AND BOARD DESIGNATOR "A1" OR "A2" (EXAMPLE: A4A1Q1)
 - HEAVY LINE — INDICATES MAIN SIGNAL PATH. CLOSED ARROWHEAD →
ON SIGNAL PATH INDICATES AC SIGNAL SUCH AS FSK AND NSK TONES.
OPEN ARROWHEAD ⇨ INDICATES VARYING DC, OR DC PULSES.

Figure FO-13. Receive A4 Module, Schematic Diagram.

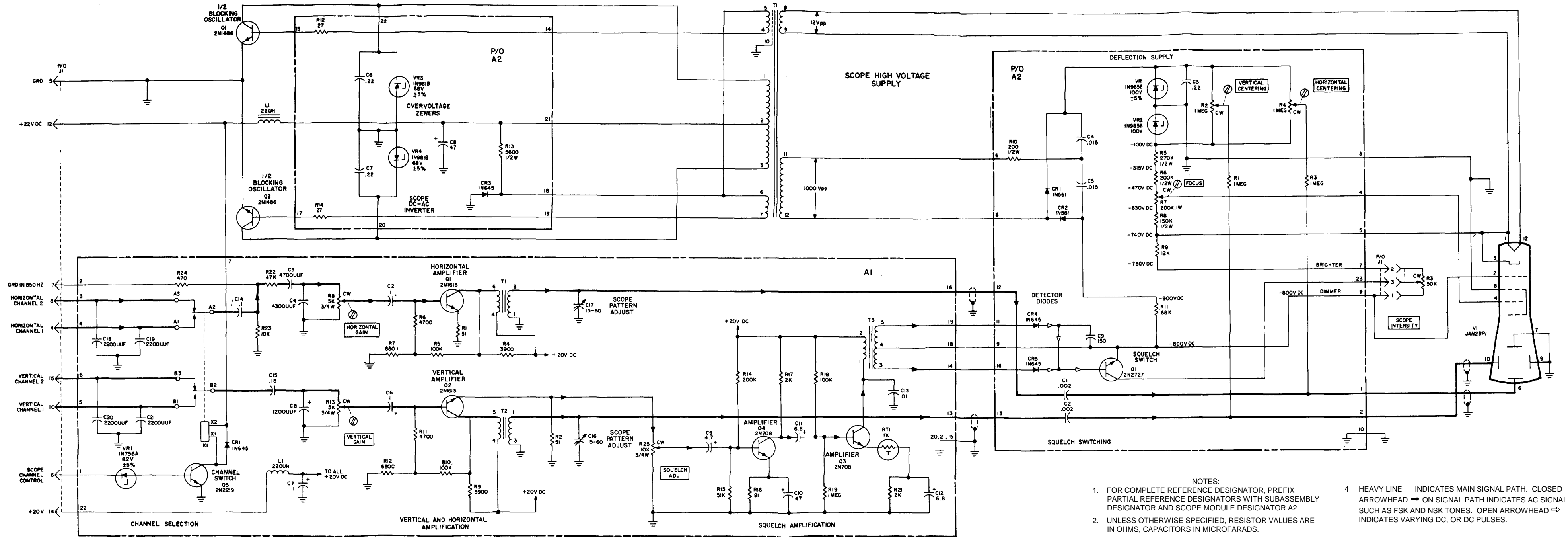

- NOTES:
1. FOR COMPLETE REFERENCE DESIGNATOR, PREFIX PARTIAL REFERENCE DESIGNATORS WITH SUBASSEMBLY DESIGNATOR AND SCOPE MODULE DESIGNATOR A2.
 2. UNLESS OTHERWISE SPECIFIED, RESISTOR VALUES ARE IN OHMS, CAPACITORS IN MICROFARADS.
 3. HIGH VOLTAGE DC MEASUREMENTS ARE MADE WITH RESPECT TO GROUND USING DC SCOPE AND HIGH VOLTAGE AC PROBE. OUTPUT OF T1 WAS MEASURED PEAK-TO-PEAK WITH SAME SCOPE AND PROBE.
 4. HEAVY LINE — INDICATES MAIN SIGNAL PATH. CLOSED ARROWHEAD → ON SIGNAL PATH INDICATES AC SIGNAL SUCH AS FSK AND NSK TONES. OPEN ARROWHEAD ⇨ INDICATES VARYING DC, OR DC PULSES.

Figure FO-14. Scope A2 Module, Schematic Diagram.

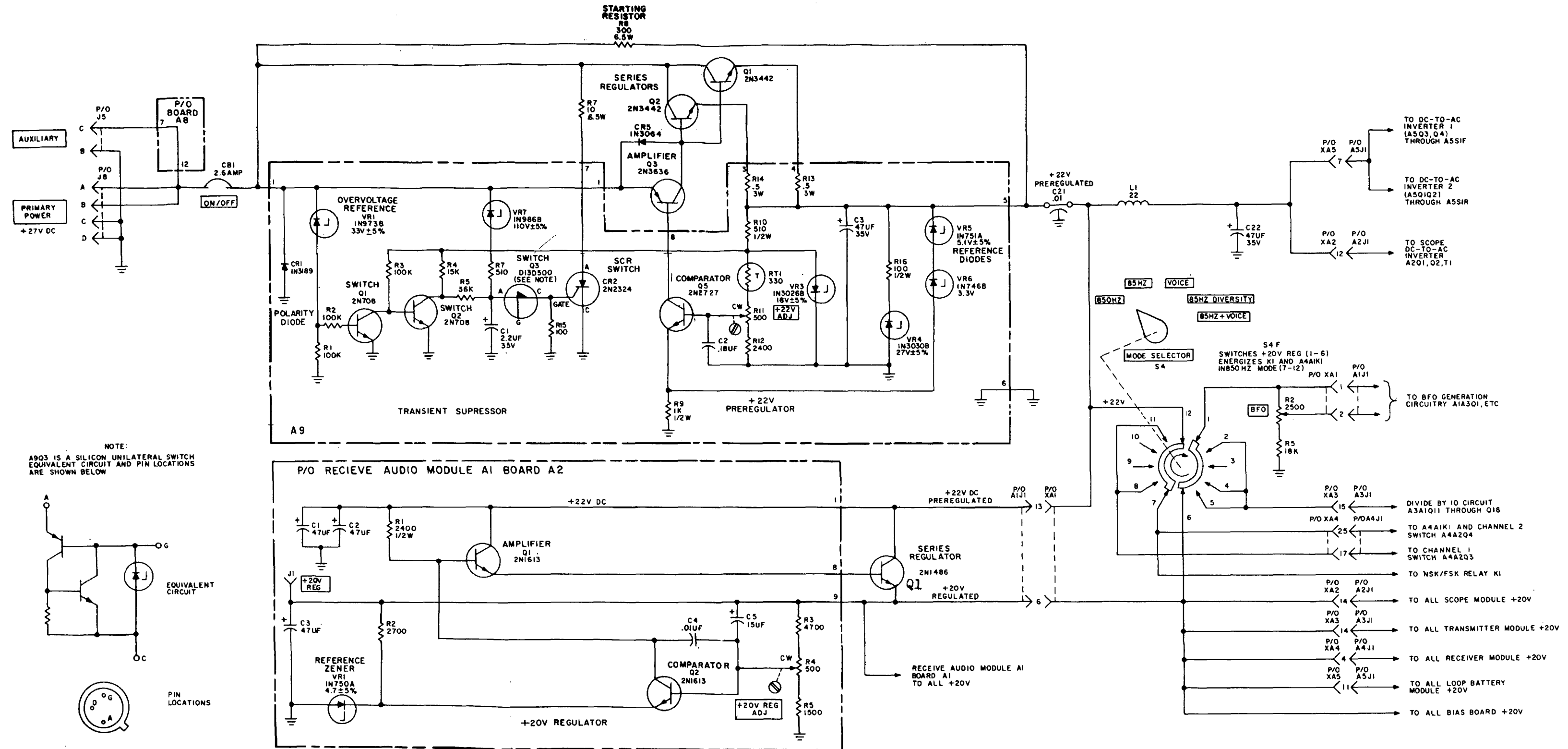

Figure FO-15. Main Power Supply, Control and Protective Circuits, Simplified Schematic Diagram.